

**BID FOR**  
**SLUDGE HAULING**

**BID # 18/19-010**

**BIDS DUE NOT LATER THAN: 1:45 PM ON SEPTEMBER 27, 2018**

**PUBLIC BID OPENING: 2:00 PM ON SEPTEMBER 27, 2018**

**[NOTE: TIME BIDS ARE DUE IS DIFFERENT FROM BID OPENING TIME]**



431 PRATER WAY  
P.O. BOX 857  
SPARKS, NV 89432-0857

Company Name: \_\_\_\_\_

**CITY OF SPARKS  
NOTICE TO BIDDERS  
SLUDGE HAULING  
BID #18/19-010**

NOTICE IS HEREBY GIVEN that the City of Sparks, Nevada, will receive written sealed bids only, for the project listed above. Said bids must be in the hands of the Contracts and Risk Manager at 431 Prater Way, Sparks, Nevada, **NO LATER THAN 1:45 PM ON SEPTEMBER 27, 2018**. Bids postmarked prior to, but not received until after this deadline will not be accepted. Vendor bid response submittals may not be sent to the City of Sparks via the Internet/e-mail and will not be entertained for award by the City of Sparks. The right is reserved to reject any Bid/Proposal or to accept the Bid/Proposal which is deemed by the City of Sparks to be in the best interest of the City of Sparks. The City of Sparks reserves the right to waive any irregularities and/or informalities in the bid process.

All Bids are to be marked clearly on the outside. Bids will be opened and publicly read at **2:00 PM ON SEPTEMBER 27, 2018**, at Sparks City Hall, 431 Prater Way Sparks, NV 89431.

**PROJECT DESCRIPTION:** Successful bidder shall transport biomass from the Truckee Meadows Water Reclamation Facility to the Lockwood Landfill in Mustang, NV as directed by the City. The City will supply the trailers that will be leased by the successful vendor from the City to be used in the transportation process. The City expects that the Contractor will need to make approximately six (6) trips per day to maintain acceptable hopper levels but the required trips will vary depending on the needs of the facility. The awarded contract shall be for a term of 12 months, with mutually agreeable options for extension for up to 4 additional years.

**BONDING/LICENSING:** A Bid Bond in the amount of 5% of bid amount is required. This bid bond will function as a penalty in the event the successful bidder fails to enter into a written contract with the City in accordance with the bid documents. Additionally, the City will be entitled to actual damages, if any. Prospective bidders will be required to have a current Contractor's License under the Nevada State Law for the type of work specified herein.

The work to be performed under this Contract shall be commenced by the successful Bidder after all executed Contract documents have been submitted, and after being notified to proceed by the City of Sparks. Pursuant to Senate Bill 26 (2017), any Contract entered into under NRS Chapter 332 in which the estimated annual dollar amount exceeds \$50,000 will require written certification that the bidder is not, and will not be, engaged in a boycott of Israel throughout the duration of the Contract.

Bid documents and specifications may be obtained from the City of Sparks website. Please visit <http://www.cityofsparks.us/bids> to obtain complete bid documents. There is no cost to use the system or obtain plans, but registration at the site is required. It is the responsibility of all potential bidders/responders to monitor the Purchasing Division's website for any changing information prior to submitting their bid/proposal. The City of Sparks will not be responsible for the timeliness or completeness of information provided by any 3<sup>rd</sup> party bid listing or re-selling service. For further information, contact the Purchasing Division at [dmarran@cityofsparks.us](mailto:dmarran@cityofsparks.us) or at (775) 353-2273. The individual responsible for coordinating this bid is: Dan Marran, CPPO, C.P.M. – Contracts and Risk Manager

Reno Gazette Journal Legal Notices Section  
Publish Date: September 12, 2018  
Proof of publication required

## **Bidder's Checklist**

Bidders are instructed to complete and return the following forms in order for their bids to be complete. Failure to return the following items may result in your bid being declared "non-responsive."

1. \_\_\_\_\_ Bid Item Schedule
2. \_\_\_\_\_ Bidder Information Sheets
3. \_\_\_\_\_ Subcontractor Information Form (5% list due with bid submittal)
4. \_\_\_\_\_ Acknowledgement and Execution Form
5. \_\_\_\_\_ Certification Regarding Debarment
6. \_\_\_\_\_ Bid Bond
7. \_\_\_\_\_ Signed Bid Addenda (if applicable)

**CITY OF SPARKS  
 BID ITEM SCHEDULE**

**BID TITLE:** Sludge Hauling (Bid #18/19-010)

**PRICES** must be valid for 90 calendar days after the bid opening.

**BIDDER** acknowledges receipt of \_\_\_\_\_ Addenda.

\_\_\_\_\_  
 Bidder Name (signature)

Item	Rate
A) <b>Hourly rate</b> including all costs (maintenance, driver expenses, lube, oil, tires, insurance, permits, lease expenses, benefits and any other expenses) <b>except fuel</b>	_____ <b>/Hour</b>
B) <b>Time per round trip</b> to landfill in hours (convert partial hours to decimal, 90 minutes should be listed as 1.5 hrs)	
C) <b>Gallons of fuel used per trip:</b>	
D) <b>Current price for fuel:</b> (changes to fuel costs will be allowed, based on actual cost and compared to applicable fuel indices)	_____/Gallon <b>Date:</b> _____ <b>Source:</b> _____ (Attach <b>copy</b> of bill or quote to support pricing)

*\*Assume a payload of 59,600 pounds*

Comparison of bids will be based upon the total cost per trip using the following calculation:

$$(\text{Hourly Rate} \times \text{Time per trip}) + (\text{Fuel per trip} \times \text{Fuel Price per gallon})$$

**Example:**

$$(\$85.00 \text{ \$/hr} \times 1.5 \text{ hr/trip}) + (5 \text{ gal per trip} \times 3.00 \text{ per gallon}) = \$142.50 \text{ per trip.}$$

**Bidder to complete:**

$$\begin{array}{ccccccc}
 (\text{_____} \times \text{_____}) & + & (\text{_____} \times \text{_____}) & = & \text{_____} & / & \text{Trip} \\
 \text{Rate/Hr} & & \text{Time} & & \text{Gallons} & & \text{Fuel Cost} & & \text{Total}
 \end{array}$$

## Bidder Information

### COMPANY INFORMATION:

Company Name:
Contact Name:
Address:
City:
State / Zip Code:
Telephone Number including area code:
Fax Number including area code:
E-mail:

### COMPANY BACKGROUND

- 1) Has your company ever failed to complete any contracts awarded to it? No\_\_\_ Yes\_\_\_ (If yes, please provide details.)
  
- 2) Has your company filed any arbitration request or law suits on contracts awarded within the last five years? No\_\_\_ Yes\_\_\_ (If yes, please provide details.)
  
- 3) Does your company now have any legal suits or arbitration claims pending or outstanding against it or any officers relating to the performance of a public contract? No\_\_\_ Yes\_\_\_ (If yes, please provide details.)
  
- 4) Does your company now employ any officers or principals who were with another firm when that company failed to complete a contract within the last five years? No\_\_\_ Yes\_\_\_ (If yes, please provide details.)
  
- 5) Has your company had a contract partially or completely terminated for default (cause) within the past five years? No\_\_\_ Yes\_\_\_ (If yes, please provide details.)
  
- 6) Has your company been found non-responsible on a government bid within the last five years? No\_\_\_ Yes\_\_\_ (If yes, please provide details.)

## Bidder Information

### CONTRACTOR LICENSE INFORMATION:

Nevada State Contractor's License Number (If Applicable):
License Classification(s):
Limitation(s) of License:
Date Issued:
Date of Expiration:
Name of Licensee:
City, State, Zip Code of Licensee:
Telephone Number of Licensee:

**BUSINESS LICENSING INFORMATION** All vendors doing business within the City of Sparks are required to obtain and maintain a current business license from the City of Sparks prior to commencement of work (Sparks Municipal Code Section 5.08.020A). Vendor(s) awarded a contract resulting from this bid shall be required to obtain a current business license if they do not already hold one.

City of Sparks Business License Number:
Date Issued:
Date of Expiration:
Name of Licensee:
City, State, Zip Code of Licensee:
Telephone Number of Licensee:
Taxpayer Identification Number:

## Bidder Information

### DISCLOSURE OF PRINCIPALS:

a) **Individual and/or Partnership:**

Owner 1) Name:
Address:
City, State, Zip Code:
Telephone Number:
Owner 2) Name:
Address:
City, State, Zip Code:
Telephone Number:
Other 1) Title:
Name
Other 2) Title:
Name:

b) **Corporation:**

State in which Company is Incorporated:
Date Incorporated:
Name of Corporation:
Address
City, State, Zip Code:
Telephone Number:
President's Name:
Vice-President's Name:
Other 1) Name:
Title:

**CITY OF SPARKS ACKNOWLEDGMENT AND EXECUTION:**

STATE OF \_\_\_\_\_ )  
 ) SS  
County of \_\_\_\_\_ )

\_\_\_\_\_(Name of Principal) being first duly sworn, deposes and says: That he/she is the Bidder, or authorized agent of the Bidder for whom the aforesaid described work is to be performed by; that he/she has read the Plans, Specifications, and related documents including but not limited to, any addenda issued and understands the terms, conditions, and requirements thereof; that if his/her bid is accepted that he/she agrees to furnish and deliver all materials except those specified to be furnished by the City of Sparks (Owner) and to do and perform all work for the **SLUDGE HAULING, Bid # 18/19-010**, together with incidental items necessary to complete the work to be constructed and/or services to be provided in accordance with the Specifications, Plans, and Contract Documents annexed hereto.

**TO THE CONTRACTS AND RISK MANAGER OF THE CITY OF SPARKS:**

The undersigned, as Bidder, declares that the only persons or parties interested in this proposal, as principals, are those named herein, the Bidder is fully informed respecting the preparation and contents of the attached Bid and of all pertinent circumstances respecting such Bid: that this proposal is made without collusion with any other person, firm or corporation; that he/she has carefully examined the location of the proposed work; the proposed form of Contract, the Contract Provisions, Plans, Specifications and Contract Documents incorporated therein referred to and made part thereof; that he/she proposes and agrees if this proposal is accepted, that he/she will contract with the City of Sparks in the form of the Contract prescribed, to provide all necessary machinery, tools, apparatus and other means of construction, and to do all the work and furnish all the materials specified in the Contract and annexed Contract Provisions, Plans and Specifications, in the manner and time prescribed and according to the requirements of the Project Representative as therein set forth, it being understood and agreed that the quantities shown herein are approximate only and are subject to increase or decrease, and that he/she will accept, in full, payment therefore the indicated prices.

(Printed Name of Contractor/Bidder) Contractor/Bidder:  
BY:  
Firm:  
Address:  
City:  
State / Zip Code:  
Telephone Number:  
Fax Number:  
E-mail Address:  
(Signature of Principal) Signature:  
DATED this \_\_\_\_\_ day of \_\_\_\_\_, 2018.

State of Nevada )  
 ) SS.  
County of \_\_\_\_\_ )

On this \_\_\_\_\_ day of \_\_\_\_\_, in the year 2018, before me,

\_\_\_\_\_/Notary Public, personally appeared \_\_\_\_\_ Personally known to me (or proved  
to me on the basis of satisfactory evidence) to be the person whose name is subscribed to this instrument, and acknowledged that he (she) executed it. WITNESS my hand and official seal.

Notary's Signature: \_\_\_\_\_ My commission Expires: \_\_\_\_\_



**CERTIFICATION REGARDING DEBARMENT, SUSPENSION, AND OTHER  
RESPONSIBILITY MATTERS**

**(This form to be signed and returned at the time of bid)**

The prospective bidder, \_\_\_\_\_ certifies to the best of its knowledge and belief that it and its principals:

- (a) Are not presently debarred, suspended, proposed for debarment, declared ineligible, or voluntarily excluded from covered transactions by any Federal department or agency;
- (b) Have not within a three year period preceding this proposal been convicted of or had a civil judgment rendered against them for commission of fraud or a criminal offense in connection with obtaining, attempting to obtain, or performing a public (Federal, State, or local) transaction or contract under a public transaction; violation of Federal or State antitrust statutes or commission of embezzlement, theft, forgery, bribery, falsification or destruction of records, making false statements, or receiving stolen property;
- (c) Are not presently indicted for or otherwise criminally or civilly charged by a government entity (Federal, State, or local) with commission of any of the offenses enumerated in paragraph (b) of this certification; and
- (d) Have not within a three-year period preceding this application/proposal had one or more public transactions (Federal, State, or local) terminated for cause or default.

I understand that a false statement on this certification may be grounds for rejection of this proposal or termination of the award. Any exceptions provided will not necessarily result in denial of award, but will be considered in determining bidder responsibility and whether or not the City will enter into contract with the party. For any exception noted, indicate on an attached sheet to whom it applies, initiating agency, and dates of action. Providing false information may result in criminal prosecution or administrative sanctions.

---

Typed Name & Title of Authorized Representative

---

Signature of Authorized Representative

Date

I am unable to certify to the above statement. My explanation is attached.

Signature \_\_\_\_\_ Date \_\_\_\_\_

**CITY OF SPARKS, NEVADA – 5% Bid Bond**

KNOW ALL MEN BY THESE PRESENTS: That we the undersigned \_\_\_\_\_, as “Principal,” and \_\_\_\_\_, as “Surety,” are hereby held and firmly bound unto the City of Sparks, Nevada, as “Obligee,” in the penal sum of \_\_\_\_\_dollars (\$\_\_\_\_\_) for the payment of which, well and truly to be made, the Principal and Surety bind themselves, their heirs, executors, and administrators, successors and assigns, jointly and severally, by this instrument. The condition of the obligation of this bid bond is as follows:

WHEREAS, NRS 332.105 authorizes local governments to require bid bonds to insure execution and proper performance of the Contract and the Bonding Company has an “A” or better rating with Moody’s or A.M. Best and T-Listed with the U.S. Treasury Department;

AND, WHEREAS, the Principal has submitted a bid for Bid # **18/19-010**, for the provision of **SLUDGE HAULING** services.

NOW, THEREFORE,

- (a) If said Bid shall be rejected; or
- (b) If said Bid shall be accepted and the Principal shall execute and deliver the contract in the bid documents (“Contract”) to Obligee in accordance with the terms of the bid documents, and give such bond or bonds as may be specified in the bid or contract documents with good and sufficient surety for the faithful performance of such Contract and for the prompt payment of labor and material furnished in the prosecution thereof; or
- (c) If the Principal shall pay to the Obligee the full amount of the bid bond as a penalty irrespective of the Obligee’s actual damages in the event of the failure of the Principal to enter into such Contract and give such bond or bonds,

then, this obligation shall be null and void. Otherwise it shall remain in full force and effect, it being expressly understood and agreed that the liability of the Surety (but not of the Principal) for any and all claims hereunder shall, in no event, exceed the penal amount of the obligation as herein stated.

The Surety, for the consideration for which this bond was executed, hereby stipulates and agrees that the obligations of said Surety and its bond shall be in no way impaired or affected by any extension of the time within which the Obligee may accept such bid, and hereby waives notice of any such extension.

**IN WITNESS WHEREOF, the Principal and the Surety have hereunto set their hands and the Surety has caused their seal to be hereto affixed and these present to be signed by their proper officers.**

Signed, Sealed and dated: \_\_\_\_\_

\_\_\_\_\_  
Principal  
By: \_\_\_\_\_

\_\_\_\_\_  
Surety  
By: \_\_\_\_\_

# **GENERAL CONDITIONS**

## General Conditions



---

### GENERAL CONDITIONS

*Please Read Carefully*

*These Provisions Are a Part of Your Bid and any Contract Awarded*

**Scope of Bid/Proposal:** Bids/Proposals are hereby requested for **SLUDGE HAULING**, as per specifications herein.

**The bidder agrees that:**

- A. Bidder has carefully examined the specifications, and all provisions relating to the item(s) to be furnished or the work to be done; understands the meaning, intent, and requirements; and
- B. Bidder will enter into a written contract and furnish the item(s) or complete the work in the time specified, and in strict conformity with the City of Sparks specifications for the prices quoted.

**Note:** Bidder is defined as any individual, partnership, or corporation submitting a bid, proposal, or quotation in response to a request for bid (RFB), request for proposal (RFP), request for information (RFI) or request for quotation (RFQ). A bidder may also be referred to as a bidder, contractor, supplier or vendor.

The use of the title "Bidder," "Vendor", "Contractor" or "Consultant" within this solicitation document and any resulting contract shall be deemed interchangeable and shall refer to the person or entity with whom the City of Sparks is soliciting and/or contracting for the service or product referenced within the bid document.

**1. Prices:**

All prices and notations must be in ink or typewritten. Mistakes may be crossed out and corrections typed or written with ink adjacent to the error. Bids shall indicate the unit price extended to indicate the total price for each item bid. Any difference between the unit price correctly extended and the total price shown for all items bid shall be resolved in favor of the unit prices. Bidders are encouraged to review all prices prior to bid submittal, as withdrawal or correction may not be permitted after the bid has been opened.

**2. Firm Prices:**

Prices on bid shall be firm prices not subject to escalation unless otherwise provided for in the specifications. In the event the specifications provide for escalation, the maximum limit shall be shown, or the bid shall not be considered. In the event of a decline in market price below a price bid, the City of Sparks shall receive the benefit of such decline.

**3. Items Offered:**

If the item offered by the bidder has a trade name, brand and/or catalog number, such shall be stated in the bid. If the bidder proposes to furnish an item of a manufacturer or vendor other than that mentioned on the face hereof, bidder must specify maker, brand, quality, catalog number, or other trade designation. Unless such is noted on the bid form, it will be deemed that the item offered is that designated even though the bid may state "or equal".

**4. Brand Names:**

Whenever reference to a specific brand name is made by the City, it is intended to describe a component that has been determined to best meet operational, performance, or reliability standards of the City, thereby incorporating these standards by reference within the specifications. These specifications are not meant to limit the vendor; they are guidelines to minimum qualifications. The bidder shall indicate their compliance or non-compliance for each line of the specification. Any deviations from the specifications or where submitted literature does not fully support the meaning of the specifications must be clearly cited in writing by the bidder.

## General Conditions



---

An equivalent (“or equal”) may be offered by the bidder, subject to evaluation and acceptance by the City. It is the bidder’s responsibility to provide, at bidder’s expense, samples, test data, or other documentation the City may require to fully evaluate and determine acceptability of an offered substitute. The City reserves the sole right to reject a substituted component that will not meet or exceed City standards.

**5. Samples:**

Samples may be required for bid evaluation and testing purposes. Bidders shall agree to provide samples upon request and at no additional cost to the City.

**6. Withdrawal of Bids:**

Bids may be withdrawn by written or facsimile notice received prior to the exact hour and date specified for receipt of bid. A bid may also be withdrawn in person by a bidder, or bidder’s authorized representative, prior to the exact hour and date set for receipt of bids. Telephone withdrawals are not permitted.

**7. Late Bids, Modifications, or Withdrawals:**

Bids, modifications of bids, or bid withdrawals received after the exact time and date specified for receipt will not be considered.

**8. Mistake in Bid:**

- (a) If the bidder discovers a mistake in bid prior to the hour and date specified for receipt of bid, bidder may correct the mistake by withdrawing the bid in accordance with Item 7 above and resubmit prior to the stated bid deadline.
- (b) If within seventy-two hours of the bid closing and prior to the issuance of a purchase order or a contract, the apparent low bidder discovers a mistake in bid of a serious and significant nature, bidder may request consideration be given to withdrawing the bid. The mistake must be evident and provable. The right is reserved by the City to reject any and all requests for withdrawal of bids. The decision of the Purchasing Manager is final as regards acceptance or rejection of requests for withdrawal after closing of bids.
- (c) A mistake in bid cannot be considered once a purchase order or contract is issued.

**9. Signature:**

All bids shall be signed and the title and firm name indicated. A bid by a corporation shall be signed by an authorized officer, employee or agent with his or her title.

**10. Exceptions:**

A bidder deviating from specifications must specify any and all deviation(s). Failure to note said exceptions shall be interpreted to convey that the bidder shall propose to perform in the manner described and/or specified in this bid solicitation. If exception(s) are taken or alternatives offered, complete descriptions must be shown separately.

**11. Confidential Information:**

Any information deemed confidential or proprietary should be clearly identified by the bidder as such. It may then be protected and treated with confidentiality only to the extent permitted by state law. Otherwise the information shall be considered a public record. Information or data submitted with a bid will not be returned.

**12. Quality:**

Unless otherwise required in the specifications, all goods furnished shall be new and unused.



---

**13. Litigation Warranty:**

The bidder, by bidding, warrants that bidder is not currently involved in litigation or arbitration concerning the materials or bidder's performance concerning the same or similar material or service to be supplied pursuant to this contract of specification, and that no judgments or awards have been made against bidder on the basis of bidder's performance in supplying or installing the same or similar material or service, unless such fact is disclosed to the City in the bid. Disclosure may not disqualify the bidder. The City reserves the right to evaluate bids on the basis of the facts surrounding such litigation or arbitration and to require bidder to furnish the City with a surety bond executed by a surety company authorized to do business in the State of Nevada and approved by The City of Sparks in a sum equal to one hundred percent (100%) of the contract price conditional on the faithful performance by bidder of the contract in the event the bid is awarded to bidder, notwithstanding the litigation or arbitration.

**14. Royalties, Licenses and Patents:**

Unless otherwise specified, the bidder shall pay all royalties, license and patent fees. The bidder warrants that the materials to be supplied do not infringe any patent, trademark or copyright and further agrees to defend any and all suits, actions and claims for infringement that are brought against the City, and to defend, indemnify and hold harmless the City from all loss or damages, whether general, exemplary or punitive, as a result of any actual or claimed infringement asserted against the City, the bidder or those furnishing material to bidder pursuant to this contract.

**15. Performance Standards:**

Performance of work and acceptability of equipment or materials supplied pursuant to any contract or award shall be to the satisfaction and full discretion of the City.

**16. Americans with Disabilities Act (ADA) Standards:**

Bidders shall be required to comply with current ADA Standards in preparing their bids and executing work required under any contract resulting from this bid. Completed work must comply with current ADA Standards.

**17. Warranties:**

(a) Unless otherwise specified, all workmanship, material, labor or equipment provided under the contract shall be warranted by bidder and/or manufacturer for a minimum of twelve (12) months after acceptance by City. Greater warranty protection will be accepted. Lesser warranty protection must be indicated by bidder on the bid proposal as an exception.

(b) Bidder shall be considered primarily responsible to the City for all warranty service, parts and labor applicable to the goods or equipment provided by bidder under this bid or award, irrespective of whether bidder is an agent, broker, fabricator or manufacturer's dealer. Bidder shall be responsible for ensuring that warranty work is performed at a local agency or facility convenient to City and that services, parts and labor are available and provided to meet City's schedules and deadlines. If required and defined within the Scope of Work, the Bidder will post a performance bond after contract award to guarantee performance of these obligations. Bidder may establish a service contract with a local agency satisfactory to City to meet this obligation if bidder does not ordinarily provide warranty service.

**18. Addenda:**

The effect of all addenda to the bid documents shall be considered in the bid, and said addenda shall be made part of the bid documents and shall be returned with them. Before submitting a bid, each bidder shall ascertain

## General Conditions



whether or not any addenda have been issued, and failure to acknowledge any such addenda may render the bid invalid and result in its rejection.

All potential bidders are responsible for monitoring the City website regarding the availability of new bid documents or addenda (where applicable). The City of Sparks will not be responsible for the results of any potential failures in automatic notification systems to potential bidders or plan holders with respect to these documents and will not adjust bid schedules or requirements due to any potential failures of those systems. It is the responsibility of all potential bidders/responders to monitor the Purchasing Division's website for any changing information prior to submitting their bid/proposal. The City of Sparks will not be responsible for the timeliness or completeness of information provided by any 3<sup>rd</sup> party bid listing or re-selling service.

### **19. Specifications to Prevail:**

The detailed requirements of the Specifications, Scope of Work or Special Conditions shall supersede any conflicting reference in these General Conditions or the stated language on the City of Sparks Standard Purchase Order that are in conflict therewith.

### **20. Taxes:**

The City is exempt from State, City and County Sales Taxes per NRS 372.325. The City will furnish Exemption Certificates for Federal Excise Tax when applicable. The successful bidder shall pay all taxes, levies, duties and assessments of every nature, which may be applicable to any work or materials under this Contract. The Contract Sum and any agreed variations thereof shall include all taxes imposed by law. The successful bidder shall make any and all payroll deductions required by law. The successful bidder herein indemnifies and holds the City harmless from any liability on account of any and all such taxes, levies, duties, assessments and deductions.

### **21. Prevailing Wages:**

Bidder is responsible for complying with all applicable local, State and Federal wage laws, whether or not specifically cited in this bid document.

Per NRS Sections 338.020 through 338.090, certain projects defined as "public works" require the payment of the prevailing wage as determined by the Labor Commissioner. Generally speaking, projects/contracts for construction of a public work valued at less than \$250,000 are exempt from the prevailing wage requirement (NRS 338.080). Bidder shall be fully aware of the prevailing wage requirements of the State of Nevada as detailed in NRS Chapter 338 and price their bid response accordingly. Further information concerning Prevailing Wage rates can be found at:

[http://labor.nv.gov/PrevailingWage/Public\\_Works/Prevailing\\_Wages/](http://labor.nv.gov/PrevailingWage/Public_Works/Prevailing_Wages/)

Federal "Davis Bacon" wages may be applicable if the funding for the project includes Federal funds. These requirements are detailed in the "Special Conditions – Federal Requirements" section that will be included in this bid document when such conditions apply.

### **22. Conflict of Interest:**

No City employee or elected or appointed member of City government, or member of the employee's immediate family, may participate directly or indirectly in the procurement process pertaining to this bid if they:

- (a) Have a financial interest or other personal interest that is incompatible with the proper discharge of their official duties in the public interest or would tend to impair their independence, judgment or action in the performance of their official duties.

## General Conditions



- (b) Are negotiating for or have an arrangement concerning prospective employment with bidder. The bidder warrants to the best of his knowledge that the submission of the bid will not create such conflict of interest. In the event such a conflict occurs, the bidder is to report it immediately to the Purchasing Manager. For breach or violation of this warranty, the City shall have the right to annul this contract without liability at its discretion, and bidder may be subject to damages and/or debarment or suspension.

### 23. Disqualification of Bidder:

Any one or more of the following may be considered as sufficient for the disqualification of a prospective Bidder and the rejection of the Bid:

- (a) The Bidder is not responsive or responsible.
- (b) The quality of services, materials, equipment or labor offered does not conform to the approved plans and specifications.
- (c) There is evidence of collusion among prospective Bidders (Participants in such collusion will receive no recognition as Bidders).
- (d) The Bidder lacks the correct contractor's license classification required for the defined scope of work.
- (e) Lack of competency, understanding of the scope of work, adequate machinery, plant and/or equipment as revealed in routine due diligence associated with bid evaluation.
- (f) Unsatisfactory performance record as shown by past work for the City of Sparks, judged from the standpoint of workmanship, progress, and quality of services/goods provided.
- (g) Uncompleted work which, in the judgment of the City of Sparks, might hinder or prevent the prompt completion of additional work, if awarded.
- (h) Failure to pay or satisfactorily settle all bills due for labor and/or material on any contract(s).
- (i) Failure to comply with any requirements of the City of Sparks.
- (j) Failure to list, as required, all subcontractors who will be employed by the Bidder.
- (k) Any other reason determined, in good faith, to be in the best interest of the City of Sparks.

### 24. Gratuities:

The City may rescind the right of the bidder to proceed under this agreement if it is found that gratuities in the form of entertainment, gifts, cash or otherwise are offered or given by the bidder, or any agent or representative of the bidder, to any officer or employee of the City with the intent of influencing award of this agreement or securing favorable treatment with respect to performance of this agreement.

### 25. Bidder's Security (This Section IS IS NOT Applicable to this bid):

A bid deposit in an amount equal to at least 5% of the bid may be required as a bid security by the City, calculated from the annual (12-month) cost of the contract. The bid security may only be in cash, a cashier's or certified check made payable to the City of Sparks, or a bid bond. If the bid security is a bond, it shall be executed by a surety insurer authorized to issue surety bonds in the State of Nevada. All Bonding Companies must have an "A" rating or better with Moody's or A.M. Best Company, and be included on the current list of "Companies Holding Certificates of Authority as Acceptable Sureties on Federal Bond and as Acceptable Reinsuring Companies" as published in circular 570 (as amended) by the audit staff, Bureau of Accounts, U.S. Treasury Department. (In other words, the company is T-listed.) The bid security must be executed by the bidder and enclosed with the bid proposal in the sealed bid envelope.

### 26. Performance and Payment Bonds:

Per NRS 339.025, before any contract, except one subject to the provisions of chapter 408 of NRS, exceeding \$100,000 for any project for the new construction, repair or reconstruction of any public building or other public work or public improvement of any contracting body is awarded to any contractor, he shall furnish to the



## General Conditions



contracting body the following bonds which become binding upon the award of the contract to the contractor (All Bonding Companies must have an “A” rating or better with Moody’s or A.M. Best Company, and be included on the current list of “Companies Holding Certificates of Authority as Acceptable Sureties on Federal Bond and as Acceptable Reinsuring Companies” as published in circular 570 (as amended) by the audit staff, Bureau of Accounts, U.S. Treasury Department. (In other words, the company is T-listed.)):

**Performance Bond (This Section  IS  IS NOT Applicable to this bid):**

The Contractor awarded this bid will be required to furnish the City with a surety bond conditioned upon the faithful performance of the contract. This may take the form of a bond executed by a surety company authorized to do business in the State of Nevada and approved by the City of Sparks. The bond shall be in a sum equal to one hundred percent (100%) of the amount of the contract price. Such bond shall be forfeited to the City in the event that bidder receiving the contract shall fail or refuse to fulfill the requirements and all terms and conditions of the contract.

**Payment Bond (This Section  IS  IS NOT Applicable to this bid):**

The Contractor awarded this bid will be required to furnish the City with a payment bond. This may take the form of a bond executed by a surety company authorized to do business in the State of Nevada and approved by the City of Sparks. The bond shall be in a sum equal to one hundred percent (100%) of the amount of the contract price. The bond must be solely for the protection of claimants supplying labor or materials to the contractor to whom the contract was awarded, or to any of his subcontractors, in the prosecution of the work provided for in such contract.

### 27. Indemnification:

To the fullest extent permitted by law, upon award, Contractor shall hold harmless, indemnify, defend and protect City, its affiliates, officers, agents, employees, volunteers, successors and assigns (“Indemnified Parties”), and each of them from and against any and all claims, demands, causes of action, damages, costs, expenses, actual attorney’s fees, losses or liabilities, in law or in equity, of every kind and nature whatsoever (“Claims”) arising out of or related to any act or omission of Contractor, its employees, agents, representatives, or Subcontractors in any way related to the performance of work under this Agreement by Contractor, or to work performed by others under the direction or supervision of Contractor, including but not limited to:

1. Personal injury, including but not limited to bodily injury, emotional injury, sickness or disease, or death to persons;
2. Damage to property of anyone, including loss of use thereof;
3. Penalties from violation of any law or regulation caused by Contractor’s action or inaction;
4. Failure of Contractor to comply with the Insurance requirements established under this Agreement;
5. Any violation by Contractor of any law or regulation in any way related to the occupational safety and health of employees.

In determining the nature of the claim against City, the incident underlying the claim shall determine the nature of the claim, notwithstanding the form of the allegations against City.

If City’s personnel are involved in defending such actions, Contractor shall reimburse City for the time and costs spent by such personnel at the rate charged City for such services by private professionals.

**In cases of professional service agreements, requiring professional liability coverage:**

**General Conditions**



If the insurer by which a Consultant is insured against professional liability does not so defend the City and applicable agents and/or staff, and the Consultant is adjudicated to be liable by a trier of fact, the City shall be entitled to reasonable attorney’s fees and costs to be paid to the City by the Consultant in an amount which is proportionate to the liability of the of the Consultant.

Nothing in this contract shall be interpreted to waive nor does the City, by entering into this contract, waive any of the provisions found in Chapter 41 of the Nevada Revised Statutes.

**28. Insurance:**

BIDDERS' ATTENTION IS DIRECTED TO THE INSURANCE REQUIREMENTS BELOW. IT IS HIGHLY RECOMMENDED THAT BIDDERS CONFER WITH THEIR RESPECTIVE INSURANCE CARRIERS OR BROKERS TO DETERMINE IN ADVANCE OF BID SUBMISSION THE AVAILABILITY OF INSURANCE CERTIFICATES AND ENDORSEMENTS AS PRESCRIBED AND PROVIDED HEREIN. IF THE APPARENT LOW BIDDER FAILS TO COMPLY STRICTLY WITH THE INSURANCE REQUIREMENTS, THAT BIDDER MAY BE DISQUALIFIED FROM AWARD OF THE CONTRACT.

Should work be required on City premises or within the public right-of-way, upon award of the contract, the bidder shall provide proof of insurance for the types of coverage, limits of insurance and other terms specified herein, prior to initiation of any services under City, Bid, Proposal or Contract. Coverage shall be from a company authorized to transact business in the State of Nevada and the City of Sparks and shall meet the following minimum specifications:

Contractor shall at its own expense carry and maintain at all times the following insurance coverage and limits of insurance no less than the following or the amount customarily carried by Contractor or any of its subcontractors, whichever is greater. Contractor shall also cause each subcontractor employed by Contractor to purchase and maintain insurance of the type specified herein. All insurers must have AM Best rating not less than A-VII, and be acceptable to the City. Contractor shall furnish copies of certificates of insurance evidencing coverage for itself and for each subcontractor. Failure to maintain the required insurance may result in termination of this contract at City’s option. If Contractor fails to maintain the insurance as set forth herein, City shall have the right, but not the obligation, to purchase said insurance at Contractor’s expense.

Contractor shall provide proof of insurance for the lines of coverage, limits of insurance and other terms specified below prior to initiation of any services. Coverage shall be from a company authorized to transact business in the State of Nevada and the City of Sparks. Contractor and any of its subcontractors shall carry and maintain coverage and limits no less than the following or the amount customarily carried by Contractor or any of its subcontractors, whichever is greater.

<b>Applicable to this Contract</b>	<b>Insurance Type</b>	<b>Minimum Limit</b>	<b>Insurance Certificate</b>	<b>Additional Insured</b>	<b>Waiver of Subrogation</b>
<b>Yes</b>	General Liability/Umbrella (Excess) Liability	\$2,000,000	✓	✓	✓
<b>Yes</b>	Automobile Liability	\$1,000,000	✓	✓	
<b>Yes</b>	Workers’ Compensation	Statutory	✓	N/A	✓
<b>Yes</b>	Employer’s Liability	\$1,000,000	✓	N/A	

**General Conditions**



<b>Applicable to this Contract</b>	<b>Insurance Type</b>	<b>Minimum Limit</b>	<b>Insurance Certificate</b>	<b>Additional Insured</b>	<b>Waiver of Subrogation</b>
<b>No</b>	Professional Liability	\$1,000,000	✓	N/A	N/A
<b>Yes</b>	Pollution Legal Liability	\$1,000,000	✓	N/A	N/A

**Commercial General Liability**

Contractor shall carry and maintain Commercial General Liability (CGL) and, if necessary to meet required limits of insurance, commercial umbrella/excess liability insurance with a total limit of not less than the limits specified herein.

For contracts that are for the construction or improvement of public facilities, the Contractor shall obtain and maintain products and completed operations liability coverage through the statute of repose after completion of the project.

There shall be no endorsement or modification of the CGL limiting the scope of coverage for liability arising from pollution, explosion, collapse, underground property damage, employment-related practices, or damage to the named insured’s work unless Subcontractor carries and maintains separate policies providing such coverage and provides Contractor evidence of insurance confirming the coverage.

***Minimum Limits of Insurance***

- \$2,000,000** Each Occurrence Limit for bodily injury and property damage
- \$2,000,000** General Aggregate Limit
- \$2,000,000** Products and Completed Operations Aggregate Limit
- \$10,000** Medical Expense Limit

If Commercial General Liability Insurance or other form with a general aggregate limit is used, it shall be revised to apply separately to this PROJECT or LOCATION.

***Coverage Form***

Coverage shall be at least as broad as the unmodified Insurance Services Office (ISO) Commercial General Liability (CGL) “Occurrence” form CG 00 01 04/13 or substitute form providing equivalent coverage and shall cover liability arising from premises, operations, independent contractors, products-completed operations, personal and advertising injury, and liability assumed under an insured contract (including the tort liability of another assumed in a business contract).

***Additional Insured***

City, its officers, agents, employees, and volunteers are to be included as insureds using the applicable ISO additional insured endorsement(s) or substitute forms providing equivalent coverage, in respects to damages and defense arising from: activities performed by or on behalf of Contractor, including the insured's general supervision of Contractor; products and completed operations of Contractor; premises owned, occupied, or used by Contractor. The coverage shall contain no special limitations on the scope of protection afforded to City, its officers, employees, or volunteers. Additional insured status for City shall apply until the expiration of time within which a claimant can bring suit per applicable state law.

## General Conditions



Any failure by the Contractor to comply with reporting provisions of the policies shall not affect its obligations to the additional insureds.

### ***Primary and Non-Contributory***

Contractor's insurance coverage shall apply as primary insurance with respect to any other insurance or self-insurance programs afforded to City, its officers, agents, employees, and volunteers. There shall be no endorsement or modification of the CGL to make it excess over other available insurance; alternatively, if the CGL states that it is excess or pro rata, the policy shall be endorsed to be primary with respect to the additional insured. Any insurance or self-insurance maintained by City, its officers, employees, or volunteers shall be excess of Contractor's insurance and shall not contribute with it in any way.

### ***Separation of Insureds***

Contractor's insurance shall apply separately to each insured against whom a claim is made or suit is brought, except with respect to the limits of the insurer's liability.

### ***Waiver of Subrogation***

Contractor waives all rights against City and its agents, officers, directors and employees for recovery of damages to the extent these damages are covered by the commercial general liability or commercial umbrella liability insurance maintained pursuant to this agreement. Insurer shall endorse CGL policy as required to waive subrogation against the City with respect to any loss paid under the policy.

### ***Endorsements***

A policy form or endorsement is required confirming coverage for all required additional insureds. The endorsement for CGL shall be at least as broad as the unmodified ISO additional insured endorsement CG 20 10 11/85 or substitute forms providing additional insured coverage for products and completed operations.

A waiver of subrogation in favor of City shall be endorsed to the policy using an unmodified Waiver of Transfer of Rights of Recovery of Others to Us ISO CG 24 04 05 09, or a substitute form providing equivalent coverage.

If any underground work will be performed, Contractor shall maintain electronic data liability insurance applicable to the Project and insuring against liability arising out of the loss of, loss of use of, damage to, corruption of, inability to access, or inability to manipulate electronic data. This coverage shall be maintained with a limit of liability of not less than \$1,000,000 and provide coverage at least as broad as electronic data liability coverage form CG 04 37 (or substitute form providing equivalent coverage).

### **Business Automobile Liability**

#### ***Minimum Limits of Insurance***

**\$1,000,000** Combined Single Limit per accident for bodily injury and property damage or the limit customarily carried by Contractor, whichever is greater. No aggregate limit may apply. Coverage may be combined with Excess/Umbrella Liability coverage to meet the required limit.

## General Conditions



---

### ***Coverage Form***

Coverage shall be at least as broad as the unmodified Insurance Services Office (ISO) Business Automobile Coverage form CA 00 01 10/13, CA 00 25 10/13, CA 00 20 10/13 or substitute form providing equivalent coverage. Such insurance shall cover liability arising out of any auto (including owned, hired, and non-owned autos).

Pollution liability coverage at least as broad as that provided under the ISO pollution liability—broadened coverage for covered autos endorsement (CA 99 48) shall be provided, and the Motor Carrier Act endorsement (MCS 90) shall be attached for all contracts involving transportation of “hazardous material” as this term is defined by applicable law, including, but not limited to, waste, asbestos, fungi, bacteria and mold.

### ***Additional Insured***

City, its officers, agents, employees, and volunteers are to be included as insureds with respect to damages and defense arising from the ownership, maintenance or use of automobiles owned, leased, hired, or borrowed by the Contractor. The coverage shall contain no special limitations on the scope of protection afforded to City, its officers, employees, or volunteers. Additional insured status for City shall apply until the expiration of time within which a claimant can bring suit per applicable state law.

### ***Endorsements***

A policy endorsement is required listing all required additional insureds. The endorsement for Business Automobile Liability shall be at least as broad as the unmodified ISO CA 20 48 10/13 or a substitute form confirming City’s insured status for Liability Coverage under the Who Is An Insured Provision contained in Section II of the coverage form ISO CA 00 01 10/13.

### **Workers’ Compensation and Employer’s Liability**

Contractor shall carry and maintain workers’ compensation and employer’s liability insurance as required by NRS 616B.627 or provide proof that compliance with the provisions of Nevada Revised Statutes Chapters 616A-D and all other related chapters is not required. It is understood and agreed that there shall be no coverage provided for Contractor or any Subcontractor of the Contractor by the City. Contractor agrees, as a precondition to the performance of any work under this Agreement and as a precondition to any obligation of the City to make any payment under this Agreement to provide City with a certificate issued by an insurer in accordance with NRS 616B.627 and with a certificate of an insurer showing coverage pursuant to NRS 617.210.

It is further understood and agreed by and between City and Contractor that Contractor shall procure, pay for and maintain the above mentioned coverage at Contractor's sole cost and expense.

Should Contractor be self-funded for workers’ compensation and employer’s liability insurance, Contractor shall so notify City in writing prior to the signing of this Contract. City reserves the right to approve said retentions, and may request additional documentation, financial or otherwise, for review prior to the signing of this Contract.

Nevada law allows the following to reject workers’ compensation coverage if they do not use employees or subcontractors in the performance of work under the contract:

- Sole proprietors (NRS 616B.627 and NRS 617.210)
- Unpaid officers of quasi-public, private or nonprofit corporations (NRS 616B.624 and NRS 617.207)
- Unpaid managers of limited liability companies (NRS 616B.624 and NRS 617.207)

**General Conditions**



- An officer or manager of a corporation or limited liability company who owns the corporation or company (NRS 616B.624 and NRS617.207)

If a contractor has rejected workers’ compensation coverage under applicable Nevada law, the contractor must indicate the basis for the rejection of coverage and complete, sign and have notarized an Affidavit of Rejection of Coverage. The Affidavit must be completed, signed and notarized prior to performance of any work.

***Minimum Limits of Insurance***

Workers’ Compensation: Statutory Limits  
Employer’s Liability: **\$1,000,000** Bodily Injury by Accident – Each Accident  
**\$1,000,000** Bodily Injury by Disease – Each Employee  
**\$1,000,000** Bodily Injury by Disease – Policy Limit

***Coverage Form***

Coverage shall be at least as broad as the unmodified National Council on Compensation Insurance (NCCI) Workers Compensation and Employer’s Liability coverage form WC 00 00 07/11 or substitute form providing equivalent coverage.

**OTHER INSURANCE COVERAGES (IF APPLICABLE)**

**Professional Liability Insurance (if Applicable)** \$1,000,000 per occurrence limits of liability or whatever limit is customarily carried by the Contractor, whichever is greater, for design, design-build or any type of professional services with a minimum of three (3) years reporting of claims following completion of the project.

**Contractors Pollution Liability Insurance (If Applicable)-** \$1,000,000 per occurrence and \$2,000,000 aggregate or whatever amount is acceptable to the City for any exposure to “hazardous materials” as this term is defined in applicable law, including but not limited to waste, asbestos, fungi, bacterial or mold.

Lower tier sub-subcontractors, Truckers, Suppliers: Evidence confirming lower tier subcontractors, truckers and suppliers are maintaining valid insurance prior to beginning work on the project to meet the requirements set forth herein on Subcontractor, including but not limited to all additional insured requirements of Subcontractor.

**ALL COVERAGES**

Coverage shall not be suspended, voided, canceled, or non-renewed by either CONTRACTOR or by the insurer, reduced in coverage or in limits except after thirty (30) days' prior written notice has been given to CITY except for ten (10) days’ notice for nonpayment of premium.

**OTHER INSURANCE PROVISIONS**

Should City and Contractor agree that higher coverage limits are needed warranting a project policy, project coverage shall be purchased and the premium for limits exceeding the above amount may be borne by City. City retains the option to purchase project insurance through Contractor's insurer or its own source.

Any failure to comply with reporting provisions of the policies shall not affect coverage provided to City, its officers, agents, employees, or volunteers.

**ACCEPTABILITY OF INSURERS**

Insurance is to be placed with insurers with a Best's rating of no less than A-VII and acceptable to the City.. City, with the approval of the Risk Manager, may accept coverage with carriers having lower Best's ratings

## General Conditions



upon review of financial information concerning Contractor and insurance carrier. City reserves the right to require that Contractor's insurer be a licensed and admitted insurer in the State of Nevada, or on the Insurance Commissioner's approved but not admitted list.

### **VERIFICATION OF COVERAGE**

Contractor shall furnish City with certificates of insurance and with original endorsements affecting coverage required by this contract. The certificates and endorsements for each insurance policy are to be signed by a person authorized by that insurer to bind coverage on its behalf.

Prior to the start of any Work, Contractor must provide the following documents to City of Sparks, Attention: Purchasing Division, P.O. Box 857, Sparks, NV 89432-0857:

- A. Certificate of Insurance.** Contractor must provide a Certificate of Insurance form to the City of Sparks to evidence the insurance policies and coverage required of Contractor.
- B. Additional Insured Endorsements.** An original Additional Insured Endorsement, signed by an authorized insurance company representative, must be submitted to the City of Sparks, by attachment to the Certificate of Insurance, to evidence the endorsement of the City of Sparks as additional insured.
- C. Policy Cancellation Endorsement.** Except for ten (10) days' notice for non-payment of premium, each insurance policy shall be endorsed to specify that without thirty (30) days prior written notice to the City of Sparks, the policy shall not be suspended, voided, cancelled or non-renewed, and shall provide that notices required by this paragraph shall be sent by certified mailed to the address specified above. A copy of this signed endorsement must be attached to the Certificate of Insurance.
- D. Bonds (as Applicable).** Bonds as required and/or defined in the original bid documents.

**All certificates and endorsements are to be addressed to the City of Sparks, Purchasing Division and be received and approved by City before work commences.** The City reserves the right to require complete certified copies of all required insurance policies at any time.

### **SUBCONTRACTORS**

Contractor shall include all Subcontractors as insureds under its policies or shall furnish separate certificates and endorsements for each Subcontractor. All coverages for Subcontractors shall be subject to all of the requirements stated herein.

### **MISCELLANEOUS CONDITIONS**

1. Contractor shall be responsible for and remedy all damage or loss to any property, including property of City, caused in whole or in part by Contractor, any Subcontractor, or anyone employed, directed, or supervised by Contractor.
2. Nothing herein contained shall be construed as limiting in any way the extent to which Contractor may be held responsible for payment of damages to persons or property resulting from its operations or the operations of any Subcontractors under it.
3. In addition to any other remedies City may have if Contractor fails to provide or maintain any insurance policies or policy endorsements to the extent and within the time herein required, City may, at its sole option:

## General Conditions



- a. Purchase such insurance to cover any risk for which City may be liable through the operations of Contractor under this Agreement and deduct or retain the amount of the premiums for such insurance from any sums due under the Agreement;
- b. Order Contractor to stop work under this Agreement and/or withhold any payments which become due Contractor here under until Contractor demonstrates compliance with the requirements hereof; or,
- c. Terminate the Agreement.

### 29. Safety Program:

Upon award, the Contractor shall be responsible for initiating, maintaining, and supervising all safety precautions and programs in connection with the work. The Contractor shall take all necessary precautions for the safety of, and shall provide all necessary protection to prevent damage, injury, or loss to:

1. All employees on the work site and all other persons who may be affected thereby.
2. All the work, materials, and equipment to be incorporated therein, whether in storage on or off the site.
3. Other property at the site or adjacent thereto, including trees, shrubs, lawns, walks, pavements, roadways, structures, and utilities not designated for removal, relocation, or replacement in the course of construction.

Contractor shall comply with all applicable laws, ordinances, rules, regulations, and others of any public authority having jurisdiction for the safety of persons or property or to protect them from damage, injury, or loss. He shall erect and maintain, as required by existing conditions and progress on the work, all necessary safeguards for safety and protection, including posting danger signs, other warnings against hazards, promulgating safety regulations, and notifying owners and users of adjacent utilities. Contractor shall comply with OSHA'S Hazard Communication Standards.

Contractor shall designate a responsible member of its organization at the site whose duty shall be the prevention of accidents. This person shall be Contractor's superintendent unless otherwise designated in writing by Contractor to the Owner and the Engineer.

### 30. Award of Contract:

- (a) Bids/Proposals will be analyzed and award will be made to the lowest, responsive and responsible bidder whose bid conforms to the solicitation and whose bid is considered to be most advantageous to the City, price and other factors considered. Factors to be considered may include, but are not limited to: bidder's past performance, total unit cost, economic cost analysis, life cycle costs, warranty and quality, maintenance cost, durability, the operational requirements of the City and any other factors which will result in the optimum economic benefit to the City.
- (b) The City reserves the right to reject any item or items, to waive informalities, technical defects and minor irregularities in bids/proposals received; and to select the bid(s) or proposal(s) deemed most advantageous to the City. Should the City elect to waive a right it will not constitute an automatic waiver of that right in the future nor will it impact any other right or remedy. The City may consider bids/proposals submitted on an "all or nothing" basis if the bid/proposal is clearly designated as such.
- (c) The City reserves the right to award one or more contracts on the bids/proposals submitted, either by award of all items to one bidder or by award of separate items or groups of items to various bidders as the interests of the City may require, unless the bidder clearly specifies otherwise in his bid.
- (d) Upon acceptance by the City of Sparks, the solicitation, bid, proposal, or price quotation and issuance of a purchase order issued to the successful bidder shall be deemed to result in a binding contract incorporating



## General Conditions



those terms and these General Conditions without further action required by either party. Items are to be furnished as described in the bid and in strict conformity with all instructions, conditions, specifications, and provisions in the complete contract, as defined by this clause or any related integrated agreement.

### 31. Request for Proposal (RFP) Submittals:

In the case of Request for Proposals (RFP's), it should be noted that the documents submitted by prospective bidders are competitive sealed proposals and not competitive sealed bids. When proposals are opened, prices and other information will not be made public until the proposal is awarded. There shall be no disclosure of any bidder's information to competing bidders prior to the award of the proposal.

By their nature, proposals will include a number of variables that will vary based on the complexity of the product or service addressed within the proposal. Therefore, the evaluation of RFP's and the recommendation for award will not be based on price alone. Selection criteria will be better defined for each scope of work in the Special Conditions section of this bid.

Upon award of the contract, the executed contract and proposals will become public information. Accordingly, each proposal should be submitted on the vendor's most favorable terms from a price and technical standpoint.

### 32. Bidder Preference Law (This Section IS IS NOT Applicable to this bid):

This project will be bid and awarded under the Provisions(s) of NRS 338.147, which restricts preference given to certain contractors on Public Works Projects. The NRS cited in this section is meant to be a reference only. Each bidder shall acquaint himself with the latest provisions of NRS 338.147.

If the Contract for any Public Works Construction Project is expected to cost \$250,000 or more, then all Contractors wishing to receive benefit of their preference status in the evaluation of bids must submit a copy of their Certificate of Bidder Preference issued by the State Contractor's Board. (Call 775-688-1141 or 775-486-1100 to obtain certification information from the State Contractors Board). Contractors who do not submit a preference certificate at the time of their bid are presumed to have wished not to exercise the benefit of their preference, or do not possess the certificate of eligibility.

To the extent Contractor has sought, qualified and receives a bidding preference on this project, pursuant to Nevada Revised Statutes Chapter 338, Contractor acknowledges and agrees that the following requirements will be adhered to, documented and attained for the duration of the Project:

1. At least 50 percent of the workers employed on the Project (including subcontractors) hold a valid driver's license or identification card issued by the Nevada Department of Motor Vehicles;
2. All vehicles used primarily for the public work will be (a) registered and (where applicable) partially apportioned to Nevada; or (b) registered in Nevada; and
3. The Contractor shall maintain and make available for inspection within Nevada all payroll records related to the Project.

Contractor recognizes and accepts that failure to comply with any requirements herein shall be a material breach of the contract and entitle the City of Sparks to liquidated damages in the amount set by statute. In addition, the Contractor recognizes and accepts that failure to comply with any requirements herein may lose its certification for a preference in bidding and/or its ability to bid on any contracts for public works pursuant to NRS Chapter

## General Conditions



338.

To the extent Contractor has sought, qualified and receives a bidding preference, and this project has a value of over \$250,000 pursuant to Nevada Revised Statutes Chapter 338, each contract between the contractor, applicant or design-build team and a subcontractor must provide for the apportionment of liquidated damages assessed pursuant to this section if a person other than the Contractor was responsible for the breach of a contract for a public work caused by a failure to comply with a requirement of Items 1-3 within this section. The apportionment of liquidated damages must be in proportion to the responsibility of each party for the breach.

This section shall not be applicable for projects in which some or all of the funding comes from Federal sources.

### **33. Tie Bids:**

Should identical low, responsive and responsible bids be received from two bidders, the City of Sparks Purchasing Manager shall notify all parties involved in the tie and may at his option utilize a coin-flip to determine the low bidder who shall be recommended for award. Or;

Should there be three or more low, responsive and responsible tie bids the Purchasing Manager shall exercise the following tie breaking method, unless another alternative is apparent and prudent: The City of Sparks Purchasing Manager shall set a mutually agreed upon time where, in his office, he shall shuffle a new deck of playing cards and have each bidder's representative cut the cards. The tie bidder who cuts the highest card (with Ace high) shall be recommended for bid award.

### **34. Appeals/Protests – Bids Only (Not Applicable to Request for Proposals):**

A person who submits a bid on a contract may, after the bids are opened and within 5 business days after the date the "Recommendation to Award" is issued by the City, unless otherwise stated in the Special Conditions, file a notice of protest regarding the awarding of the contract. The City's "Recommendation to Award" will be dated and posted on the City's public website within the area where bid notices and bid re-caps are posted (Currently: <http://www.cityofsparks.us/bids>).

- (a) A notice of protest must include a written statement setting forth with specificity the reasons the person filing the notice believes the applicable provisions of law were violated.
- (b) A person filing a notice of protest may be required by the governing body or its authorized representative, at the time the notice of protest is filed, to post a bond with a good and solvent surety authorized to do business in this State or submit other security, in a form approved by the governing body or its authorized representative, to the governing body or its authorized representative who shall hold the bond or other security until a determination is made on the protest. A bond posted or other security submitted with a notice of protest must be in an amount equal to the lesser of:
  - (1) Twenty-five percent of the total value of the bid submitted by the person filing the notice of protest;
  - or
  - (2) Two hundred fifty thousand dollars (\$250,000).
- (c) A notice of protest filed in accordance with the provisions of this section operates as a stay of action in relation to the awarding of any contract until a determination is made by the governing body or its authorized representative on the protest.
- (d) A person who submits an unsuccessful bid may not seek any type of judicial intervention until the governing body or its authorized representative has made a determination on the protest and awarded the contract.

## General Conditions



- (e) A governing body or its authorized representative is not liable for any costs, expenses, attorney's fees, loss of income or other damages sustained by a person who submits a bid, whether or not the person files a notice of protest pursuant to this section.
- (f) If the protest is upheld, the bond posted or other security submitted with the notice of protest must be returned to the person who posted the bond or submitted the security. If the protest is rejected, a claim may be made against the bond or other security by the governing body or its authorized representative in an amount equal to the expenses incurred by the governing body or its authorized representative because of the unsuccessful protest. Any money remaining after the claim has been satisfied must be returned to the person who posted the bond or submitted the security.

### **35. Documentation:**

Due to the time constraints that affect contract performance, all required documents, certificates of insurance and bonds shall be provided to the City within ten (10) calendar days following award or date of request by City, whichever is later. Any failure to comply may result in bid being declared non-responsive and rejected, and at City's option, the bid bond may be attached for damages suffered.

### **36. Discounts:**

- (a) Prompt payment discounts will not be considered in evaluating bids for award. However, offered discounts will be taken if payment is made within the discount period, even though not considered in the evaluation of bids.
- (b) In connection with any discount offered, time will be computed from date of delivery and acceptance, or invoice receipt, whichever is later. Payment is deemed to be made for the purpose of earning the discount on the date of mailing of the City check.
- (c) Any discount offered other than for prompt payment should be included in the net price quoted and not included in separate terms. In the event this is not done, the City reserves the right to accept the discount offered and adjust prices accordingly on the Purchase Order.

### **37. Seller's Invoice:**

Invoices shall be prepared and submitted in duplicate to the address shown on the Purchase Order. Separate invoices are required for each Purchase Order. Invoices shall contain the following information: Purchase Order number, item number, description of supplies or services, sizes, unit of measure, quantity, unit price and extended totals.

### **38. Inspection and Acceptance:**

Inspection and acceptance will be at destination unless specified otherwise, and will be made by the City department shown in the shipping address or other duly authorized representative of the City. Until delivery and acceptance, and after any rejection, risk of loss will be on the bidder unless loss results from negligence of the City.

### **39. Lost and Damaged Shipments:**

Risk of loss or damage to items prior to the time of their receipt and acceptance by the City is upon the bidder. The City has no obligation to accept damaged shipments and reserves the right to return at the bidder's expense damaged merchandise even though the damage was not apparent or discovered until after receipt of the items.

### **40. Late Shipments:**

Bidder is responsible to notify the City department receiving the items and the Purchasing Manager of any late or delayed shipments. The City reserves the right to cancel all or any part of an order if the shipment is not made as promised.



---

**41. Document Ownership:**

All technical documents and records originated or prepared pursuant to this contract, including papers, reports, charts, and computer programs, shall be delivered to and become the exclusive property of the City and may be copyrighted by the City. Bidder assigns all copyrights to City by undertaking this agreement.

**42. Advertisements, Product Endorsements:**

City employees and agencies or organizations funded by the City of Sparks are prohibited from making endorsements, either implied or direct, of commercial products or services without written approval of the City Manager. No bidder may represent that the City of Sparks has endorsed their product or service without prior written approval.

**43. Optional Cooperative Purchase Agreement**

It is intended that any other public agency (i.e., city, county, district, public agency, municipality or state agency) shall have the option to participate (A.K.A. "join" or "piggyback") in any award made as a result of this solicitation. The City of Sparks shall incur no financial responsibility in connection with purchase orders or contracts made by the bidder with another public agency resulting from this solicitation. The public agency utilizing the original contract shall accept sole responsibility for placing orders and making applicable payments to the vendor. Should the Bidder not wish for a contract resulting from this bid to be used by other public agencies, they have the option to decline that option at the time of request.

**44. Vendor Workplace Policies**

No Vendor providing a service, program or activity to the public on behalf of the City shall discriminate against any person because of sex, race, color, creed, national origin or disability. Vendor, if providing a service, program or activity to the public on behalf of the City, shall comply with the Americans with Disability Act and City's policies pursuant thereto when providing said service, program or activity.

The City of Sparks is an Affirmative Action/Equal Opportunity Employer. Bidders shall be cognizant of the requirements for compliance with Executive Order 11246, entitled "Equal Employment Opportunity" as amended by Executive Order 11375 and as supplemented in regulations of the U.S. Department of Labor (41 CFR part 60).

**45. Business License Requirement:**

All companies doing business with, or within, the City of Sparks are required to obtain and maintain a current business license from the City of Sparks prior to the commencement of work per Sparks Municipal Code Section 5.08.020A. Bidder(s) awarded a contract resulting from this bid shall be required to obtain a current business license if they do not already possess one.

**46. City Provisions to Prevail:**

Except as indicated in the specifications, the City's standard General Conditions shall govern any contract award. Any standard terms and conditions of bidder submitted by bidder shall not be acceptable to City unless expressly agreed to by the City. The City reserves the right to reject bidder's bid as non-responsive, to consider the bid without bidder's standard terms and conditions, or to require bidder to delete reference to such, as a condition of evaluation or award of the bid. If, after award of contract, bidder (contract vendor) provides materials or services accompanied by new or additional standard terms or conditions, they too shall be considered void and City may require deletion as a further condition of performance by vendor.

## General Conditions



---

### 47. Invalid Provisions:

In the event that any one or more of the provisions of this agreement shall be found to be invalid, illegal or unenforceable, the remaining provisions shall remain in effect and be enforceable.

### 48. Amendments and Modifications:

The Purchasing Manager may at any time, by written order, and without notice to the sureties, make a modification to the contract or an amendment to the Purchase Order, within the general scope of this contract, in (1) quantity of materials or service, whether more or less; (2) drawings, designs, or specifications, where the supplies to be furnished are to be specially manufactured for the City; (3) method of shipment or packing; and (4) place of delivery. If any such change causes an increase or decrease in the cost or the time required for the performance of this contract, an equitable adjustment shall be made by written modification of the contract or amendment to the Purchase Order. Any claim by the bidder for adjustment under this clause must be asserted within 30 calendar days from the notification date.

### 49. Assignment:

Vendor shall not assign or delegate duties or responsibilities under this agreement, in whole or in part, without prior written approval of the City.

### 50. Disputes After Award:

Except as otherwise provided in these provisions, any dispute concerning a question of fact arising under this contract which is not disposed of by agreement shall be decided by the Purchasing Manager, who shall reduce this decision to writing and mail a copy to the bidder. The decision of the Purchasing Manager shall be final and conclusive, unless bidder requests arbitration within ten (10) calendar days. Pending final decision of a dispute, the bidder shall proceed diligently with the performance of the contract and in accordance with the Purchasing Manager's decision.

### 51. Arbitration after Award:

Any and all disputes, controversies or claims arising under or in connection with the contract resulting from this bid, including without limitation, fraud in the inducement of this Contract, or the general validity or enforceability of this Contract, shall be governed by the laws of the State of Nevada without giving effect to conflicts of law principles, may be submitted to binding arbitration before one arbitrator, and shall be conducted in accordance with the Commercial Arbitration Rules of the American Arbitration Association in a private manner in Washoe County, Nevada. This award shall be final and judgment may be entered upon it in any court having jurisdiction thereof. In reaching this final award, the arbitrator shall have no authority to change or modify any provision of this Contract. All other expenses of arbitration shall be borne equally by the parties. All fees, including legal fees, shall be borne by the party who incurred them. All costs of enforcement shall be borne by the losing party. Each party shall have the right to discovery in accordance with the Nevada Rules of Civil Procedure.

### 52. Lawful Performance:

Vendor shall abide by all Federal, State and Local Laws, Ordinances, Regulations, and Statutes as may be related to the performance of duties under this agreement. In addition, all applicable permits and licenses required shall be obtained by the vendor, at vendor's sole expense.

### 53. Annual Appropriation of Funds:

Multi-year term supply and service contracts and leases are subject to annual appropriation of funds by the City Council. The City plans and makes appropriations to the City Budget with respect to a fiscal year that starts July 1<sup>st</sup> and ends June 30<sup>th</sup> of each year. Payments made under term contracts and leases are considered items

## General Conditions



of current expense. Purchase Orders are funded when issued; therefore, they are current expense items and are not subject to any subsequent appropriation of funds.

Continuance of a multi-year contract beyond the limits of funds available shall be contingent upon appropriation of the requisite funds in the ensuing fiscal year and the termination of this contract due to lack of appropriation shall be without penalty.

### **54. Extension:**

When in the City's best interest, this agreement may be extended on a daily, month-to-month, or annual basis by mutual agreement of both parties. Services and/or materials received under an extension shall be in accordance with pricing, terms, and conditions, as described herein.

### **55. Termination:**

The City may terminate this agreement and be relieved of any consideration to the vendor should vendor fail to perform in the manner required. Furthermore, the City may terminate this agreement for any reason without penalty upon giving thirty (30) days written notice to the vendor. In the event of termination, the full extent of City liability shall be limited to an equitable adjustment and payment for materials and/or services authorized by and received to the satisfaction of the City prior to termination.

### **56. Venue:**

This agreement shall be governed by and interpreted according to the laws of the State of Nevada, and venue for any proceeding shall be in Washoe County.

### **57. Boycott of Israel: Compliance with SB 26 (2017) (This Section IS IS NOT Applicable to this bid):**

Pursuant to Nevada Senate Bill 26 (2017), any Contract entered into under NRS Chapter 332 in which the estimated annual dollar amount exceeds \$50,000 will require written certification that the bidder is not, and will not be, engaged in a Boycott of Israel throughout the duration of the Contract. The term "Boycott of Israel" has the meaning ascribed in Section 3 of Senate Bill 26 (2017). Bidder certifies that it is not, and will not be, engaged in a Boycott of Israel throughout the duration of the Contract.

# **Special Conditions and Specifications (Specific to Project)**

**In instances where the Special Conditions conflict with the General Conditions, the Special Conditions will prevail with respect to that instance or item(s).**

## **Background**

Land application of biosolids is regulated at the federal level by the 40 CFR 503 Rule, which defines the minimum standards required for land application of biosolids (defining processing methods, which determine the vector attraction reduction and the pathogen level, as well as defining the concentration of metals, crops allowed, and site access restrictions).

The City of Sparks is the operator of the Truckee Meadows Water Reclamation Facility (TMWRF) which produces about 250 cubic yards per day of bio-solids in conducting its dewatering operations. Production is relatively constant with variations resulting from centrifuge feed changes, digesters going in or coming out of service and/or sludge production in other plant processes. The resulting dewatered bio-solids will be transported to the Lockwood Landfill for disposal. However, no minimum volume of biosolids is guaranteed. The actual quantity of material may vary from the estimated amount and may be reduced to zero. The City of Sparks reserves the right to utilize bio-solids in any manner allowed by law with a corresponding reduction in the volume of material being disposed of at landfill.

Storage capacity at the facility is limited and operations are generally 24 hours per day, 7 days per week. Storage capacity is sufficient that if the hoppers are empty on an afternoon, operations can generally continue for 24 hours before the hoppers would be full and dewatering operations would need to cease. The biosolids contractor will communicate to TMWRF staff the end of day hopper levels and TMWRF staff will check that against hopper levels and subsequently agree that hauling operations for that day are completed. Generally TMWRF operates on a schedule designed to eliminate weekend use of the Waste Management facility in Lockwood, NV. This is done to mitigate the increased costs to TMWRF for weekend use of this facility. The biosolids contractor will be available for hauling loads at the frequency and interval that keep the TMWRF facility operational. The biosolids contractor will work with TMWRF to develop communication protocols that engender efficient and safe biosolids operation.

### **Service Requirements**

**The Contractor will be responsible for maintaining hopper levels at a level that will allow for continuous uninterrupted operation.** The City expects that the Contractor will need to make approximately six (6) trips per day to maintain acceptable hopper levels but the required trips will vary depending on the needs of the facility. Each time the trailer is loaded, the driver will be responsible for conducting a paint filter test and pH test before leaving the facility. This test is described in the attached *Paint Filter Test Standard Operating Procedure*. The successful bidder will be required to carry copies provided by TMWRF staff of the *TMWRF Bio-Solids Spill Response Plan* and the most recent Washoe County biosolids permit in the vehicles used to haul biosolids.

### **Full Loads Required:**

The Contractor will be required to haul and average load of 22-24.5 tons or a full load depending on conditions. TMWRF has camera access to the loadout area and will periodically spot check trailers for full loads. TMWRF pays a per trip fee so routine hauling of short loads verified by camera will result in a credit being requested by TMWRF from the



biosolids contractor. That credit will be limited to a maximum of four (4) trip fees per month as agreed upon by mutual discussion between contractor and TMWRF.

Overfilled loads can spill out on corners and a certain amount of expansion of loads has been observed during summer months. The contracted biosolids hauler will be expected to take all overfill and underfill considerations into account on a per trip basis. TMWRF staff will be available early in the contracted period to assist the biosolids contractor with this process.

### **Equipment Requirements**

The successful bidder will supply at least two tractors of the type necessary to legally and efficiently pull the biosolids trailers from the treatment plant to the Lockwood landfill. One of the tractors may be assigned to other operations but must be available to haul biosolids from TMWRF should the normal tractor be unavailable for any reason. The successful bidder is responsible for maintaining the tractors in good mechanical condition and maintaining compliance with all applicable local, state and federal laws and regulations. .

### **Trailer Lease**

Two side-dump trailers are available for lease from the City of Sparks by the successful bidder at a nominal rate of \$1.00 per month per trailer. All maintenance, repair, and required insurance related to the trailers is the responsibility of the contractor. Trailers will be returned to the city in condition received less normal wear and tear. Trailers will only be used to transport bio-solids from the Truckee Meadows Water Reclamation Facility. The trailer lease will be an agreement separate of the contract for services to haul materials. Samples of both contracts are included in the "Sample Forms" section of this bid. As required by the National Biosolids Partnership's Code of Good Practice, Contractor will describe, or reference, their preventive maintenance plan for trucks, trailers, and any other equipment used for the management of biosolids. All trucks and trailers are to be properly maintained to provide a safe transport of biosolids. All necessary measures are taken to keep biosolids contained. The mechanical maintenance schedule of truck tractors follows the manufacturers' recommendations and the records are kept in the office of the biosolids contractor. The structural integrity of truck trailers are also tested by visual inspection and repaired accordingly to avoid accidents and biosolids releases.

### **Operating Expenses**

Contractor agrees to bear all costs and expenses incidental to the operation of the equipment, whether empty or loaded, including without limitation, all risks of depreciation, all maintenance (including cleaning and washing), oil, tires, repairs, business taxes, consumption and sales taxes, personal taxes, ad valorem taxes, ton-mile taxes, insurance coverage required herein, workers compensation premiums if required, payroll taxes, licenses, vehicle registration renewal fees, base plates, and all highway, bridge and ferry tolls. If the City is required to withhold or pay any taxes or make any other payment with respect to fees owed by contractor, contractor will reimburse the City or permit the City to make deduction for taxes or other payments required from any monies owed to contractor. City will pay all tipping fees directly to the relevant disposal/reuse site.

**Payment:**

Loads transported to the Lockwood landfill will be paid on a per trip basis as calculated in the bid award with the fuel cost being adjusted for current conditions. Trips to other locations will be paid based on actual hours/fuel required to complete the trip at the hourly rate defined in the Bid Item Schedule.

Truckee Meadows Water Reclamation Facility  
**Standard Operation Procedure**

Page 1 of 2

**BIO-SOLIDS (CAKE) PAINT FILTER AND PH TESTING**

Number: 1

[Author:] Brian D. Mitts  
 [Title:] Operator II

Issue #: 6

Date:  
 10/10/2011

Approved:

**PURPOSE:**

The purpose of this SOP is to provide and identify the operator qualifications required, procedural instruction, and specification information for the unloading and authorization to transport the dewatered bio-solids sludge (cake) to an approved landfill.

**QUALIFICATION:**

The operator shall be authorized to test and verify the proper unloading of the dewatered bio-solids (cake).

**PAINT FILTER TEST:**

**SCOPE AND APPLICATION:**

- This method is used to determine the presence of free liquids in a representative sample of waste.
- The method is used to determine compliance with 40 CFR 264.314 and 265.314.

**SUMMARY OF METHOD:**

- A 100-mL or 100-g representative sample is required for the test. If it is not possible to obtain a sample of 100-mL or 100-g that is sufficiently representative of the waste, the analyst may use larger size samples in multiples of 100 mL or 100 g, i.e. 200, 300, 400 mL or g. However, when larger samples are used, analysts shall divide the sample into 100- mL or 100-g portions and test each test each portion separately. If any portion contains free liquid the entire sample is considered to have free liquids. If any portion of the material passes through and drops from the filter within the 5-min test period, the material is deemed to contain free liquids as referenced per **U.S. EPA. SW-846 Method 9095B, Paint Filter Liquids Test, Update IIIB, Revision 2, 2004**. If there is any free liquid present, then the load cannot be directed to the landfill. Notify your Crew Supervisor and seek instruction.

**INTERFERENCES:**

- Temperature can affect the test results if the test is performed below the freezing point of any liquid in the sample. Tests must be performed above the freezing point and can, but are not required to, exceed room temperature of 25 deg. C.

**APPARATUS AND MATERIALS:**

- Conical paint filter -- Mesh number 60 +/- 5% (fine meshed size).
- Funnel -- If the paint filter, with the waste, cannot sustain its weight on the ring stand, then a fluted funnel or glass funnel with a mouth large enough to allow at least 1 in. of the filter mesh to protrude should be used to support the filter. The funnel should be fluted or have a large open mouth in order to support the paint filter yet not interfere with the movement, to the graduated cylinder, of the liquid that passes through the filter mesh.
- Ring stand and ring, or tripod.
- Graduated cylinder or beaker -- 100-mL. Two of these will be needed, one for the 100 mL sample and another clean beaker for identification of free liquid under the paint filter.

**pH TESTING:**

- Using the pH strips provided, the operator shall insert the strip into the sample and compare the color results to the graduated pH color scale on the strip container. **Ph cannot exceed 12.0.** If pH exceeds 12.0, notify your crew supervisor and seek instruction.

**TRUCK LOADING:**

- The truck shall be evenly loaded and not exceed a level above 2 feet below the sides and end to avoid spillage during transport.



## Biosolids Management Program Code of Good Practice

### Code of Good Practice

The Code of Good Practice (the Code) is a broad framework of goals and commitments to guide the production, management, transportation, storage, and use or disposal of biosolids. Those who embrace the Code and participate in the National Biosolids Partnership (NBP) commit to “do the right thing.” Specifically, code subscribers and NBP participants pledge to uphold the following principles of conduct:

**Compliance:** To commit to compliance with all applicable federal, state, and local requirements regarding production at the wastewater treatment facility, and management, transportation, storage, and use or disposal of biosolids away from the facility.

**Product:** To provide biosolids that meet the applicable standards for their intended use or disposal.

**NBP Biosolids Management Program:** To develop a Biosolids Management Program that includes a method of independent third-party verification to ensure effective ongoing biosolids management.

**Quality Monitoring:** To enhance the monitoring of biosolids production and management practices.

**Quality Practices:** To require good housekeeping practices for biosolids production, processing, transport, and storage, and during final biosolids use or disposal operations.

**Contingency and Emergency Response Plans:** To develop response plans for unanticipated events such as inclement weather, spills, and equipment malfunctions.

**Sustainable Management Practices and Operations:** To enhance the environment by committing to sustainable, environmentally acceptable biosolids management practices and operations through a Biosolids Management Program.

**Preventive Maintenance:** To prepare and implement a plan for preventive maintenance for equipment used to manage biosolids and wastewater solids.

**Continual Improvement:** To seek continual improvement in all aspects of biosolids management.

**Communications:** To provide methods of effective communication with gatekeepers, stakeholders, and interested citizens regarding the key elements of each Biosolids Management Program, including information relative to program performance.

REVISIONS		
DATE	SYM.	DESCRIPTION
--		

GROSS VEHICLE WEIGHT 94,000  
 TRAILER 16,400  
 TRACTOR (EST.) 18,000  
 NET PAYLOAD 59,600

11R22.5 TIRES ON ALUMINUM WHEELS  
 STANDARD HUBS / CAST BRAKE DRUMS  
 AIRRIDE SUSPENSION / AIR LIFT 3RD AXLE  
 MARK V LANDING LEGS

WEIGHTS +/- 3%  
 DIMENSIONS +/- 1 1/2"

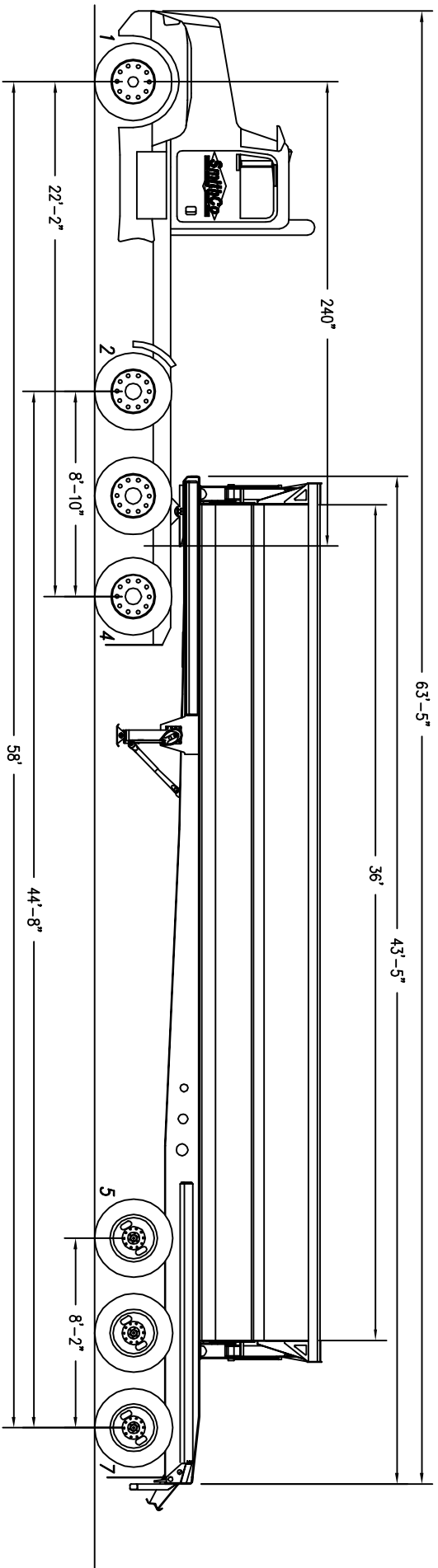

13,000 LBS.

40,000 LBS.

41,000 LBS.

**BRIDGE LAW**

BRIDGE	AXLES	DISTANCE	DOT ALLOWED WEIGHT	ACTUAL WEIGHT
1-4	4	22'	56,500	53,000
1-7	7	58'	94,000	94,000
2-4	3	9'	43,000	40,000
2-7	6	45'	81,000	81,000
5-7	3	8'	42,000	41,000

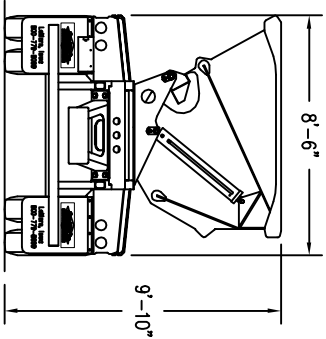

CONTROLLING CRITERIA

CHANGING TRACTOR LENGTH AND/OR WEIGHT CAN EFFECT THE BRIDGE LAW WEIGHTS AND THEREFORE THE NET PAYLOAD.  
 THE ABOVE IS SMITHCO'S UNDERSTANDING OF THE BRIDGE LAW AND WEIGHT LAW FOR THE GIVEN STATE. IT IS THE CUSTOMERS RESPONSIBILITY TO VERIFY IT.

ITEM	QTY	PART NUMBER	DESCRIPTION	MATL	WT
This drawing and the design it covers are the property of Smithco. They are loaned merely and on the borrower's expressed agreement that they will not be reproduced copied loaned exhibited nor used except in the limited way and private use permitted by any written consent given by the lender to borrower. DRAWN BY: J. VERROS CHECKED BY: DO NOT SCALE PRINT UNLESS OTHERWISE SPECIFIED: 1/16 DIMENSIONS ARE IN INCHES TOLERANCES ARE: 3 PLACE DEC. 2 PLACE DEC. ANGLES 10/30' SCALE: 1/90 DATE: 07-20-06 SHEET 1 OF 1 REV. -- TITLE: NET PAYLOAD using SMITHCO SIDE DUMP TRAILER NEVADA - SH.#63					

NEVADA - SH.#63

DATE	SYMBOL	REVISIONS DESCRIPTION	AUTHORITY
--	--		--

GROSS VEHICLE WEIGHT 94,000  
 TRAILER 16,400  
 TRACTOR (EST.) 18,000  
 NET PAYLOAD 59,600

11R22.5 TIRES ON ALUMINUM WHEELS  
 STANDARD HUBS / CAST BRAKE DRUMS  
 AIRRIDE SUSPENSION / AIR LIFT 3RD AXLE  
 MARK V LANDING LEGS

WEIGHTS +/- 3%  
 DIMENSIONS +/- 1 1/2"

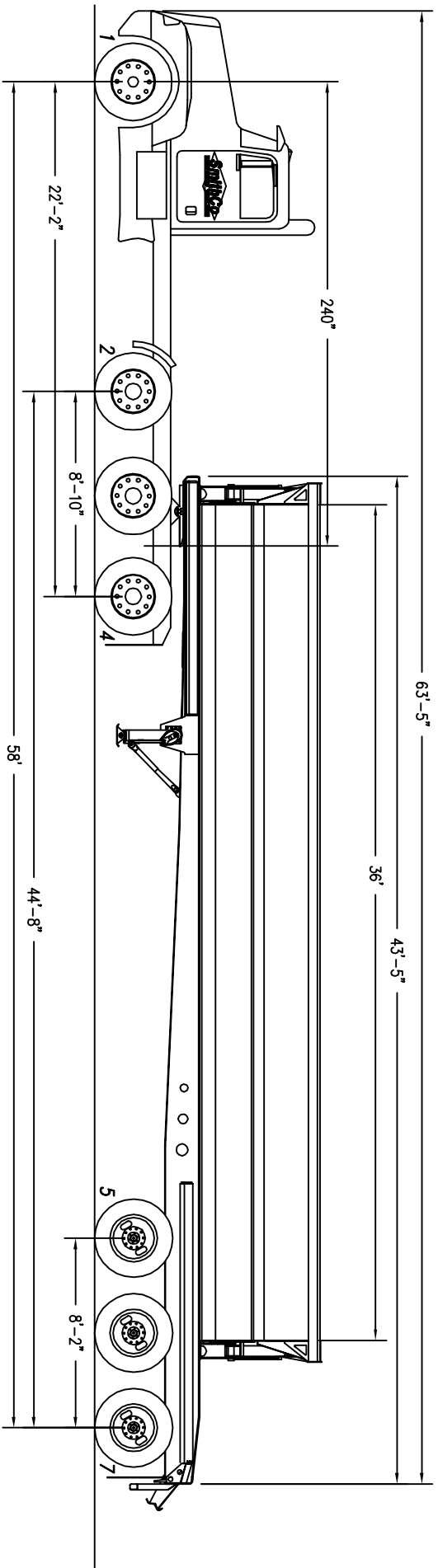

13,000 LBS.

40,000 LBS.

41,000 LBS.

**BRIDGE LAW**

BRIDGE	AXLES	DISTANCE	DOT ALLOWED WEIGHT	ACTUAL WEIGHT
1-4	4	22'	56,500	53,000
1-7	7	58'	94,000	94,000
2-4	3	9'	43,000	40,000
2-7	6	45'	81,000	81,000
5-7	3	8'	42,000	41,000

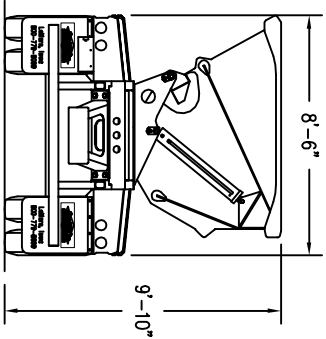

CONTROLLING CRITERIA

CHANGING TRACTOR LENGTH AND/OR WEIGHT CAN EFFECT THE BRIDGE LAW WEIGHTS AND THEREFORE THE NET PAYLOAD.  
 THE ABOVE IS SMITHCO'S UNDERSTANDING OF THE BRIDGE LAW AND WEIGHT LAW FOR THE GIVEN STATE. IT IS THE CUSTOMERS RESPONSIBILITY TO VERIFY IT.

ITEM	QTY	PART NUMBER	DESCRIPTION	MATL	WT
This drawing and the design it covers are the property of Smithco. They are loaned merely and on the borrower's expressed agreement that they will not be reproduced copied loaned exhibited nor used except in the limited way and provide use permitted by any written consent given by the lender to borrower. DRAWN BY: J. VERROS CHECKED BY: DO NOT SCALE PRINT UNLESS OTHERWISE SPECIFIED: 1/16 DIMENSIONS ARE IN INCHES TOLERANCES ARE: 3 PLACE DEC. 2 PLACE DEC. ANGLES 10/30'					
			TITLE: NET PAYLOAD using SMITHCO SIDE DUMP TRAILER		
SCALE: 1/90 DATE: 07-20-06			SHEET 1 OF 1 REV. --		
NEVADA - SH.#63					

# **Forms**

**(to be used following award of bid)**

- 1) Contract Form**
- 2) Performance Bond**
- 3) Payment Bond**
- 4) Lease Agreement for Trailer**





**GENERAL SERVICE CONTRACT  
CITY OF SPARKS, NEVADA**

THIS CONTRACT made and entered into on this DAY day of MONTH, 20YR, by and between the City of Sparks, Nevada, a municipal corporation, existing under and by virtue of the laws of the State of Nevada, hereinafter called "City", and **VENDOR**, a qualified vendor in the class of work required, hereinafter called "Vendor".

**W I T N E S E T H**

WHEREAS, the City has awarded a contract to Vendor for performing the work hereinafter mentioned in accordance with the proposal of said Vendor;

WHEREAS, the Vendor will perform the work for the compensation stated in said proposal, for an amount which has been arrived at after negotiations between the parties;

WHEREAS, each party is willing to and does assume joint liability for the contents of this Contract, and each party accordingly agrees that it shall not be construed against any party as a drafting party;

NOW, THEREFORE, IT IS AGREED as follows:

**1. Scope of Work:**

The scope of work for this contract is generally defined as **PROJECTTITLE**. The City's Contract Documents and Vendor's Entire Proposal are on file with the City of Sparks. All terms, conditions and requirements contained in these Documents, including any and all addenda issued by the City, are hereby incorporated into this Contract.

The Vendor shall perform within the time stipulated, the Contract as herein defined and shall provide and furnish any and all of the labor, materials, methods or processes, equipment implements, tools, machinery and equipment, and all utility, transportation and other services required to construct, install and put in complete order for use in a good and workmanlike manner all of the work covered by the Contract in connection with strict accordance with the plans and specifications therefore, which were approved by said City and are on file with the City, including any and all addenda issued by the City, and with the other contract documents hereinafter enumerated.

**2. Payment for Services**

As full consideration for the Services to be performed by Vendor, City agrees to pay Vendor as set forth in accordance with the Fee Schedule set forth in the proposal, bid or quotation and not to exceed fee of **COST**. The City will not hire or directly compensate the Vendor's employees, assistants or subcontractors, if any. It is expressly understood and agreed that all work done by Vendor shall be subject to review as to its result by the City at the City's discretion. Payment of any invoice shall not be taken to mean that the City is satisfied with Vendor's services to the date of payment and shall not forfeit City's right to require the correction of any deficiencies.



**3. Term (Check One)**

- This is a One-Time Service, or**
- This is a term contract from (MO/DY/YR) to (MO/DY/YR)**

The Vendor shall perform the services called for in the specifications/proposal and within the time specified and in accordance with the terms of the contract. The Vendor shall not alter or vary any terms or conditions contained or incorporated herein, including but not limited to, the quantity, price, delivery date or date designated as After Receipt of Order (ARO) or date for commencement or completion of services as mutually agreed upon, unless such alteration or variation is consented to in writing by a duly authorized representative of the City.

The City reserves the right to cancel resultant Contract upon ten days written notice in the event the type and quality of the work performance is unsatisfactory or in default, subject to Vendor’s right to cure as outlined in termination clause.

This is a non-exclusive Contract and the City reserves the right to acquire the services at its discretion, from other sources during the term of this Contract.

**4. No Unfair Employment Practices:**

In connection with the performance of work under this Agreement, Vendor agrees not to discriminate against any employee or applicant because of race, creed, color, national origin, disability, sex, sexual orientation or age. Such agreement shall include, but not be limited to, the following: recruitment or recruitment advertising, rates or pay or other forms of compensation, and selection. Any violation of these provisions by Vendor shall constitute a material breach of contract.

**5. No Illegal Harassment:**

Violation of the City’s harassment policy, which is incorporated by reference and available from the Human Resource Division, by the Vendor, its officers, employees, agents, consultants, subcontractors and anyone from whom it is legally liable, while performing or failing to perform Vendor’s duties under this Contract shall be considered a material breach of contract.

**6. Lawful Performance:**

Vendor shall abide by all Federal, State and Local Laws, Ordinances, Regulations, and Statutes as may be related to the performance of duties under this agreement. In addition, all applicable permits and licenses required shall be obtained by the vendor, at vendor’s sole expense.

**7. Licenses and Permits:**

The Vendor shall procure at his own expense all necessary licenses and permits and shall adhere to all the laws, regulations and ordinances applicable to the performance of this Contract.

All Vendors, Contractors, Sub-Contractors and Suppliers doing business within the City of Sparks are required to obtain a current business license from the City of Sparks prior to commencement of this contract. Per Sparks Municipal Code Section 5.08.020A: “It is unlawful for any person to transact business in the City without first having obtained a license from the City to do so and without complying with all applicable provisions of this title and paying the fee therefore.”



**8. Acceptance by the City:**

It is expressly understood and agreed that all materials provided and/or work done by the Vendor shall be subject to inspection and acceptance by the City at its discretion, and that any progress inspections and approval by the City of any item or work shall not forfeit the right of the City to require the correction of faulty workmanship or material at any time during the course of the work, although previously approved by oversight. Nothing herein contained shall relieve the Vendor of the responsibility for proper construction and maintenance of the work, materials and equipment required under the terms of this Contract until all work has been completed and accepted by the City.

**9. Waiver:**

No waiver of any term, provision or condition of this Contract, whether by conduct or otherwise, in any one or more instances, shall be deemed to be nor shall it be construed as a further or continuing waiver of any such term, provision or condition of this Contract. No waiver shall be effective unless it is in writing and signed by the party making it.

**10. Notices:**

All notices required to be given in writing by this Contract shall be deemed to be received (i) upon delivery if personally delivered, or (ii) when receipt is signed for if mailed by certified or registered mail, postage prepaid, or by express delivery service or courier, when addressed as follows (or sent to such other address as a Party may specify in a notice to the others):

PURCHASING MANAGER  
CITY OF SPARKS  
431 PRATER WAY  
PO BOX 857  
SPARKS, NV 89432-0857

VENDOR:

\_\_\_\_\_  
\_\_\_\_\_  
\_\_\_\_\_

**11. Jurisdiction and Venue:**

Any action or proceeding seeking to do so must be brought in the courts of the State of Nevada, County of Washoe, or if the party can acquire subject-matter jurisdiction, in the United States District Court for the District of Nevada in the City of Reno. Each of the parties consents to the personal jurisdiction of such courts (and of the appropriate appellate courts) in any such action or proceeding and waives any objection to venue laid therein. Process in any action or proceeding referred to in the preceding sentence may be served on either party by sending it certified mail to the respective addresses designated for notice.

**12. Indemnification:**

To the fullest extent permitted by law, upon award, Contractor shall hold harmless, indemnify, defend and protect City, its affiliates, officers, agents, employees, volunteers, successors and assigns (“Indemnified Parties”), and each of them from and against any and all claims, demands, causes of action, damages, costs, expenses, actual attorney’s fees, losses or liabilities, in law or in equity, of every kind and nature whatsoever (“Claims”) arising out of or related to any act or omission of Contractor, its employees, agents, representatives, or Subcontractors in any way related to the performance of work under this Agreement by Contractor, or to work performed by others under the direction or supervision of Contractor, including but not limited to:



1. Personal injury, including but not limited to bodily injury, emotional injury, sickness or disease, or death to persons;
2. Damage to property of anyone, including loss of use thereof;
3. Penalties from violation of any law or regulation caused by Contractor’s action or inaction;
4. Failure of Contractor to comply with the Insurance requirements established under this Agreement;
5. Any violation by Contractor of any law or regulation in any way related to the occupational safety and health of employees.

In determining the nature of the claim against City, the incident underlying the claim shall determine the nature of the claim, notwithstanding the form of the allegations against City.

If City’s personnel are involved in defending such actions, Contractor shall reimburse City for the time and costs spent by such personnel at the rate charged City for such services by private professionals.

**In cases of professional service agreements, requiring professional liability coverage:**

If the insurer by which a Consultant is insured against professional liability does not so defend the City and applicable agents and/or staff, and the Consultant is adjudicated to be liable by a trier of fact, the City shall be entitled to reasonable attorney’s fees and costs to be paid to the City by the Consultant in an amount which is proportionate to the liability of the of the Consultant.

Nothing in this contract shall be interpreted to waive nor does the City, by entering into this contract, waive any of the provisions found in Chapter 41 of the Nevada Revised Statutes.

**13. Insurance:**

BIDDERS’ ATTENTION IS DIRECTED TO THE INSURANCE REQUIREMENTS BELOW. IT IS HIGHLY RECOMMENDED THAT BIDDERS CONFER WITH THEIR RESPECTIVE INSURANCE CARRIERS OR BROKERS TO DETERMINE IN ADVANCE OF BID SUBMISSION THE AVAILABILITY OF INSURANCE CERTIFICATES AND ENDORSEMENTS AS PRESCRIBED AND PROVIDED HEREIN. IF THE APPARENT LOW BIDDER FAILS TO COMPLY STRICTLY WITH THE INSURANCE REQUIREMENTS, THAT BIDDER MAY BE DISQUALIFIED FROM AWARD OF THE CONTRACT.

Should work be required on City premises or within the public right-of-way, upon award of the contract, the bidder shall provide proof of insurance for the types of coverage, limits of insurance and other terms specified herein, prior to initiation of any services under City, Bid, Proposal or Contract. Coverage shall be from a company authorized to transact business in the State of Nevada and the City of Sparks and shall meet the following minimum specifications:

Contractor shall at its own expense carry and maintain at all times the following insurance coverage and limits of insurance no less than the following or the amount customarily carried by Contractor or any of its subcontractors, whichever is greater. Contractor shall also cause each subcontractor employed by Contractor to purchase and maintain insurance of the type specified herein. All insurers must have AM Best rating not less than A-VII, and be acceptable to the City. Contractor shall furnish copies of certificates of insurance evidencing coverage for itself and for each subcontractor. Failure to maintain the



required insurance may result in termination of this contract at City’s option. If Contractor fails to maintain the insurance as set forth herein, City shall have the right, but not the obligation, to purchase said insurance at Contractor’s expense.

Contractor shall provide proof of insurance for the lines of coverage, limits of insurance and other terms specified below prior to initiation of any services. Coverage shall be from a company authorized to transact business in the State of Nevada and the City of Sparks. Contractor and any of its subcontractors shall carry and maintain coverage and limits no less than the following or the amount customarily carried by Contractor or any of its subcontractors, whichever is greater.

Applicable to this Contract	Insurance Type	Minimum Limit	Insurance Certificate	Additional Insured	Waiver of Subrogation
Yes	General Liability/Umbrella (Excess) Liability	\$2,000,000	✓	✓	✓
Yes	Automobile Liability	\$1,000,000	✓	✓	
Yes	Workers’ Compensation	Statutory	✓	N/A	✓
Yes	Employer’s Liability	\$1,000,000	✓	N/A	
No	Professional Liability	\$1,000,000	✓	N/A	N/A
No	Pollution Legal Liability	\$1,000,000	✓	N/A	N/A

**Commercial General Liability**

Contractor shall carry and maintain Commercial General Liability (CGL) and, if necessary to meet required limits of insurance, commercial umbrella/excess liability insurance with a total limit of not less than the limits specified herein.

For contracts that are for the construction or improvement of public facilities, the Contractor shall obtain and maintain products and completed operations liability coverage through the statute of repose after completion of the project.

There shall be no endorsement or modification of the CGL limiting the scope of coverage for liability arising from pollution, explosion, collapse, underground property damage, employment-related practices, or damage to the named insured’s work unless Subcontractor carries and maintains separate policies providing such coverage and provides Contractor evidence of insurance confirming the coverage.

***Minimum Limits of Insurance***

**\$2,000,000** Each Occurrence Limit for bodily injury and property damage

**\$2,000,000** General Aggregate Limit

**\$2,000,000** Products and Completed Operations Aggregate Limit

**\$10,000** Medical Expense Limit



---

If Commercial General Liability Insurance or other form with a general aggregate limit is used, it shall be revised to apply separately to this PROJECT or LOCATION.

***Coverage Form***

Coverage shall be at least as broad as the unmodified Insurance Services Office (ISO) Commercial General Liability (CGL) "Occurrence" form CG 00 01 04/13 or substitute form providing equivalent coverage and shall cover liability arising from premises, operations, independent contractors, products-completed operations, personal and advertising injury, and liability assumed under an insured contract (including the tort liability of another assumed in a business contract).

***Additional Insured***

City, its officers, agents, employees, and volunteers are to be included as insureds using the applicable ISO additional insured endorsement(s) or substitute forms providing equivalent coverage, in respects to damages and defense arising from: activities performed by or on behalf of Contractor, including the insured's general supervision of Contractor; products and completed operations of Contractor; premises owned, occupied, or used by Contractor. The coverage shall contain no special limitations on the scope of protection afforded to City, its officers, employees, or volunteers. Additional insured status for City shall apply until the expiration of time within which a claimant can bring suit per applicable state law.

Any failure by the Contractor to comply with reporting provisions of the policies shall not affect its obligations to the additional insureds.

***Primary and Non-Contributory***

Contractor's insurance coverage shall apply as primary insurance with respect to any other insurance or self-insurance programs afforded to City, its officers, agents, employees, and volunteers. There shall be no endorsement or modification of the CGL to make it excess over other available insurance; alternatively, if the CGL states that it is excess or pro rata, the policy shall be endorsed to be primary with respect to the additional insured. Any insurance or self-insurance maintained by City, its officers, employees, or volunteers shall be excess of Contractor's insurance and shall not contribute with it in any way.

***Separation of Insureds***

Contractor's insurance shall apply separately to each insured against whom a claim is made or suit is brought, except with respect to the limits of the insurer's liability.

***Waiver of Subrogation***

Contractor waives all rights against City and its agents, officers, directors and employees for recovery of damages to the extent these damages are covered by the commercial general liability or commercial umbrella liability insurance maintained pursuant to this agreement. Insurer shall endorse CGL policy as required to waive subrogation against the City with respect to any loss paid under the policy.

***Endorsements***

A policy form or endorsement is required confirming coverage for all required additional insureds. The endorsement for CGL shall be at least as broad as the unmodified ISO additional insured endorsement CG 20 10 11/85 or substitute forms providing additional insured coverage for products and completed



operations.

A waiver of subrogation in favor of City shall be endorsed to the policy using an unmodified Waiver of Transfer of Rights of Recovery of Others to Us ISO CG 24 04 05 09, or a substitute form providing equivalent coverage.

If any underground work will be performed, Contractor shall maintain electronic data liability insurance applicable to the Project and insuring against liability arising out of the loss of, loss of use of, damage to, corruption of, inability to access, or inability to manipulate electronic data. This coverage shall be maintained with a limit of liability of not less than \$1,000,000 and provide coverage at least as broad as electronic data liability coverage form CG 04 37 (or substitute form providing equivalent coverage).

### **Business Automobile Liability**

#### ***Minimum Limits of Insurance***

**\$1,000,000** Combined Single Limit per accident for bodily injury and property damage or the limit customarily carried by Contractor, whichever is greater. No aggregate limit may apply. Coverage may be combined with Excess/Umbrella Liability coverage to meet the required limit.

#### ***Coverage Form***

Coverage shall be at least as broad as the unmodified Insurance Services Office (ISO) Business Automobile Coverage form CA 00 01 10/13, CA 00 25 10/13, CA 00 20 10/13 or substitute form providing equivalent coverage. Such insurance shall cover liability arising out of any auto (including owned, hired, and non-owned autos).

Pollution liability coverage at least as broad as that provided under the ISO pollution liability—broadened coverage for covered autos endorsement (CA 99 48) shall be provided, and the Motor Carrier Act endorsement (MCS 90) shall be attached for all contracts involving transportation of “hazardous material” as this term is defined by applicable law, including, but not limited to, waste, asbestos, fungi, bacteria and mold.

#### ***Additional Insured***

City, its officers, agents, employees, and volunteers are to be included as insureds with respect to damages and defense arising from the ownership, maintenance or use of automobiles owned, leased, hired, or borrowed by the Contractor. The coverage shall contain no special limitations on the scope of protection afforded to City, its officers, employees, or volunteers. Additional insured status for City shall apply until the expiration of time within which a claimant can bring suit per applicable state law.

#### ***Endorsements***

A policy endorsement is required listing all required additional insureds. The endorsement for Business Automobile Liability shall be at least as broad as the unmodified ISO CA 20 48 10/13 or a substitute form confirming City’s insured status for Liability Coverage under the Who Is An Insured Provision contained in Section II of the coverage form ISO CA 00 01 10/13.



**Workers' Compensation and Employer's Liability**

Contractor shall carry and maintain workers' compensation and employer's liability insurance as required by NRS 616B.627 or provide proof that compliance with the provisions of Nevada Revised Statutes Chapters 616A-D and all other related chapters is not required. It is understood and agreed that there shall be no coverage provided for Contractor or any Subcontractor of the Contractor by the City. Contractor agrees, as a precondition to the performance of any work under this Agreement and as a precondition to any obligation of the City to make any payment under this Agreement to provide City with a certificate issued by an insurer in accordance with NRS 616B.627 and with a certificate of an insurer showing coverage pursuant to NRS 617.210.

It is further understood and agreed by and between City and Contractor that Contractor shall procure, pay for and maintain the above mentioned coverage at Contractor's sole cost and expense.

Should Contractor be self-funded for workers' compensation and employer's liability insurance, Contractor shall so notify City in writing prior to the signing of this Contract. City reserves the right to approve said retentions, and may request additional documentation, financial or otherwise, for review prior to the signing of this Contract.

Nevada law allows the following to reject workers' compensation coverage if they do not use employees or subcontractors in the performance of work under the contract:

- Sole proprietors (NRS 616B.627 and NRS 617.210)
- Unpaid officers of quasi-public, private or nonprofit corporations (NRS 616B.624 and NRS 617.207)
- Unpaid managers of limited liability companies (NRS 616B.624 and NRS 617.207)
- An officer or manager of a corporation or limited liability company who owns the corporation or company (NRS 616B.624 and NRS 617.207)

If a contractor has rejected workers' compensation coverage under applicable Nevada law, the contractor must indicate the basis for the rejection of coverage and complete, sign and have notarized an Affidavit of Rejection of Coverage. The Affidavit must be completed, signed and notarized prior to performance of any work.

***Minimum Limits of Insurance***

Workers' Compensation: Statutory Limits  
Employer's Liability: **\$1,000,000** Bodily Injury by Accident – Each Accident  
**\$1,000,000** Bodily Injury by Disease – Each Employee  
**\$1,000,000** Bodily Injury by Disease – Policy Limit

***Coverage Form***

Coverage shall be at least as broad as the unmodified National Council on Compensation Insurance (NCCI) Workers Compensation and Employer's Liability coverage form WC 00 00 07/11 or substitute form providing equivalent coverage.





**OTHER INSURANCE COVERAGES (IF APPLICABLE)**

**Professional Liability Insurance (if Applicable)** \$1,000,000 per occurrence limits of liability or whatever limit is customarily carried by the Contractor, whichever is greater, for design, design-build or any type of professional services with a minimum of three (3) years reporting of claims following completion of the project.

**Contractors Pollution Liability Insurance (If Applicable)-** \$1,000,000 per occurrence and \$2,000,000 aggregate or whatever amount is acceptable to the City for any exposure to “hazardous materials” as this term is defined in applicable law, including but not limited to waste, asbestos, fungi, bacterial or mold.

Lower tier sub-subcontractors, Truckers, Suppliers: Evidence confirming lower tier subcontractors, truckers and suppliers are maintaining valid insurance prior to beginning work on the project to meet the requirements set forth herein on Subcontractor, including but not limited to all additional insured requirements of Subcontractor.

**ALL COVERAGES**

Coverage shall not be suspended, voided, canceled, or non-renewed by either CONTRACTOR or by the insurer, reduced in coverage or in limits except after thirty (30) days' prior written notice has been given to CITY except for ten (10) days' notice for nonpayment of premium.

**OTHER INSURANCE PROVISIONS**

Should City and Contractor agree that higher coverage limits are needed warranting a project policy, project coverage shall be purchased and the premium for limits exceeding the above amount may be borne by City. City retains the option to purchase project insurance through Contractor's insurer or its own source.

Any failure to comply with reporting provisions of the policies shall not affect coverage provided to City, its officers, agents, employees, or volunteers.

**ACCEPTABILITY OF INSURERS**

Insurance is to be placed with insurers with a Best's rating of no less than A-VII and acceptable to the City. City, with the approval of the Risk Manager, may accept coverage with carriers having lower Best's ratings upon review of financial information concerning Contractor and insurance carrier. City reserves the right to require that Contractor's insurer be a licensed and admitted insurer in the State of Nevada, or on the Insurance Commissioner's approved but not admitted list.

**VERIFICATION OF COVERAGE**

Contractor shall furnish City with certificates of insurance and with original endorsements affecting coverage required by this contract. The certificates and endorsements for each insurance policy are to be signed by a person authorized by that insurer to bind coverage on its behalf.

Prior to the start of any Work, Contractor must provide the following documents to City of Sparks, Attention: Purchasing Division, P.O. Box 857, Sparks, NV 89432-0857:



- 
- A. **Certificate of Insurance.** Contractor must provide a Certificate of Insurance form to the City of Sparks to evidence the insurance policies and coverage required of Contractor.
  
  - B. **Additional Insured Endorsements.** An original Additional Insured Endorsement, signed by an authorized insurance company representative, must be submitted to the City of Sparks, by attachment to the Certificate of Insurance, to evidence the endorsement of the City of Sparks as additional insured.
  
  - C. **Policy Cancellation Endorsement.** Except for ten (10) days' notice for non-payment of premium, each insurance policy shall be endorsed to specify that without thirty (30) days prior written notice to the City of Sparks, the policy shall not be suspended, voided, cancelled or non-renewed, and shall provide that notices required by this paragraph shall be sent by certified mailed to the address specified above. A copy of this signed endorsement must be attached to the Certificate of Insurance.
  
  - D. **Bonds (as Applicable).** Bonds as required and/or defined in the original bid documents.

**All certificates and endorsements are to be addressed to the City of Sparks, Purchasing Division and be received and approved by City before work commences.** The City reserves the right to require complete certified copies of all required insurance policies at any time.

### **SUBCONTRACTORS**

Contractor shall include all Subcontractors as insureds under its policies or shall furnish separate certificates and endorsements for each Subcontractor. All coverages for Subcontractors shall be subject to all of the requirements stated herein.

### **MISCELLANEOUS CONDITIONS**

1. Contractor shall be responsible for and remedy all damage or loss to any property, including property of City, caused in whole or in part by Contractor, any Subcontractor, or anyone employed, directed, or supervised by Contractor.
2. Nothing herein contained shall be construed as limiting in any way the extent to which Contractor may be held responsible for payment of damages to persons or property resulting from its operations or the operations of any Subcontractors under it.
3. In addition to any other remedies City may have if Contractor fails to provide or maintain any insurance policies or policy endorsements to the extent and within the time herein required, City may, at its sole option:
  - a. Purchase such insurance to cover any risk for which City may be liable through the operations of Contractor under this Agreement and deduct or retain the amount of the premiums for such insurance from any sums due under the Agreement;
  - b. Order Contractor to stop work under this Agreement and/or withhold any payments which become due Contractor here under until Contractor demonstrates compliance with the requirements hereof; or,
  - c. Terminate the Agreement.



**14. Liquidated Damages (This Section  IS  IS NOT Applicable to this Contract):**

If the service is not completed within the time stipulated in the bid, the Vendor shall pay to the City of Sparks as fixed, agreed and liquidated damages for delay and not as a penalty (it being impossible to determine the actual damages occasioned by the delay) \$ \_\_\_\_\_ for each calendar day of delay until delivery is completed; the Vendor shall be liable to the City of Sparks for the amount herein. This amount may be deducted from money due or to become due to the Vendor as compensation under this proposal in the event the Vendor fails to meet delivery schedules or product specifications.

**15. Material Breach of Contract:**

In the event Vendor fails in their delivery of services as contracted for herein, to the satisfaction of the City of Sparks or otherwise fails to perform any provisions of this Contract, the City, after providing five (5) days written notice and vendor’s failure to cure such breach, may without waiving any other remedy, make good the deficiencies and deduct the actual cost of providing alternative services from payment due the Vendor. Non-performance after the first notice of non-performance shall be considered a material breach of contract.

**16. Force Majeure:**

Neither party to the Contract shall be held responsible for delay or default caused by fire, riot, acts of God, and/or war which is beyond that party's reasonable control. City may terminate the Contract upon written notice after determining such delay or default will reasonably prevent successful performance of the Contract.

**17. Termination:**

Failure to Cure:

The City may terminate the Contract for material breach of contract upon ten (10) days written notice and recover all damages, deducting any amount still due the Vendor from damages owed to the City, or seek other remedy including action against all bonds. The Vendor may terminate the Contract for material breach of contract upon thirty (30) days written notice to the City.

Non-Funding:

Continuance of this contract beyond the fiscal year (July – June) in which the contract was initiated shall be contingent upon appropriation of the requisite funds in the ensuing fiscal year(s) and the termination of this contract due to lack of appropriation shall be without penalty.

Convenience:

The City may terminate this agreement for any reason without penalty upon giving thirty (30) days written notice to the Vendor. In the event of termination, the full extent of City liability shall be limited to an equitable adjustment and payment for materials and related services authorized by and received to the satisfaction of the City prior to termination.

**18. Assignment:**

All of the terms, conditions and provisions of this Contract, and any amendments thereto, shall inure to the benefit of and be binding upon the parties hereto, and their respective successors and assigns. The Vendor shall not assign this Contract without the written consent of the City which will not be unreasonably



withheld.

**19. Boycott of Israel: Compliance with SB 26 (2017) (This Section  IS  IS NOT Applicable to this Contract):**

Pursuant to Nevada Senate Bill 26 (2017), any Contract entered into under NRS Chapter 332 in which the estimated annual dollar amount exceeds \$50,000 will require written certification that the bidder is not, and will not be, engaged in a Boycott of Israel throughout the duration of the Contract. The term “Boycott of Israel” has the meaning ascribed in Section 3 of Senate Bill 26 (2017). Vendor hereby certifies that it is not, and will not be, engaged in a Boycott of Israel throughout the duration of this Contract.

**20. Entire Contract:**

This Contract constitutes the entire agreement of the parties and shall supersede all prior offers, negotiations, agreements and contracts whether written or oral. Any modifications to the terms and conditions of this Contract must be in writing and signed by both parties.

**21. Severability:**

If any part of this Contract is found to be void it will not affect the validity of the remaining terms of this Contract which will remain in full force and effect.

**22. Headings:**

Paragraph titles or captions contained in this Contract are inserted only as a matter of convenience and for reference only, and in no way define, limit, extend, or describe the scope of this Contract or the intent of any provision thereof.

**23. Singular Includes the Plural; Gender; Title Reference:**

Whenever the singular number is used in this Contract and when required by the context, the same shall include the plural, and the use of any gender, be it masculine, feminine or neuter, shall include all of the genders, and the word “person” or “entity” shall include corporation, firm, partnership, or any other combination or association.

The use of the title “Bidder”, “Vendor”, “Contractor” or “Consultant” within this contract or associated bid document shall be deemed interchangeable and shall refer to the person or entity with whom the City of Sparks is contracting for the service or product referenced within this contract.

**24. Execution:**

The parties agree to execute such additional documents and to take such additional actions as are reasonably necessary or desirable to carry out the purposes hereof. They also agree, acknowledge and represent that all corporate authorizations have been obtained for the execution of this Contract and for the compliance with each and every term hereof. Each undersigned officer, representative or employee represents that he or she has the authority to execute this Contract on behalf of the party for whom he or she is signing.



IN WITNESS WHEREOF, the City of Sparks has caused this Contract to be executed by its officers thereunto duly authorized and the Consultant has subscribed same, all on the day and year first above written.

\_\_\_\_\_  
(Vendor)

CITY OF SPARKS, NEVADA  
A Municipal Corporation

By: \_\_\_\_\_

By: \_\_\_\_\_  
(Authorized Signature)

\_\_\_\_\_  
(Title)

APPROVED AS TO FORM

ATTEST:

\_\_\_\_\_  
City Attorney

\_\_\_\_\_  
City Clerk (As Required)

# CITY OF SPARKS, NEVADA - BOND OF FAITHFUL PERFORMANCE

Bid #: \_\_\_\_\_

Bond #: \_\_\_\_\_

Surety Rating: \_\_\_\_\_

NV License #: \_\_\_\_\_

Appt. Agent Countersigning - List below with address

KNOW ALL MEN BY THESE PRESENTS: That WHEREAS, the City of Sparks in the State of Nevada has awarded to **(CONTRACTOR NAME)** hereinafter designated as the "Principal" a contract for Bid # **BID NUMBER**, PWP # **PWP NUMBER**, for the **PROJECT TITLE** and

WHEREAS, said Principal is required under the terms of said contract to furnish a bond for the faithful and proper performance of the Contract and the Bonding Company has an "A" or better rating with Moody's or A.M. Best and T-Listed with the U.S. Treasury Department;

NOW, THEREFORE, we the Principal and \_\_\_\_\_ as Surety, are held and firmly bound unto the City of Sparks in the State of Nevada, in the penal sum of **(WRITTEN COST)** dollars (\$\_\_\_\_\_), lawful money of the United States, being not less than one hundred percent (100%) of the estimated contract cost of the work, for the payment of which sum well and truly to be made, we bind ourselves, our heirs, executors, administrators and successors, jointly and severally, firmly by these presents.

THE CONDITION OF THIS OBLIGATION IS SUCH that if the above bound Principal, his or its heirs, executors, administrators, successors or assigns, shall in all things stand to and abide by, and well and truly keep and faithfully perform the covenants, conditions and agreements in the said contract and any alterations made as therein provided on his or their part to be kept and performed at the time and in the manner therein specified, and in all respects according to their true intent and meaning, and shall indemnify and save harmless the City of Sparks in the State of Nevada, its officers and agents as therein stipulated, then this obligation shall become null and void; otherwise, it shall be and remain in full force and virtue.

As a condition precedent to the satisfactory completion of the said contract, the above obligation shall hold good for a period of one (1) year after the completion and acceptance of the said work, during which time, if the above bounden principal, his or its heirs, executors, administrators, successors or assigns shall fail to make full, complete and satisfactory repair and replacements or totally protect the said City of Sparks in the State of Nevada from loss or damage made evident during said period of one (1) year from the date of acceptance of said works, and resulting from or caused by defective materials or faulty workmanship in the prosecution of the work done, the obligation in the said sum of **(WRITTEN COST)** dollars (\$\_\_\_\_\_ ) shall remain in full force and virtue; otherwise the above obligation shall be void.

And the said Surety, for value received, hereby stipulates and agrees that no change, extension of time, alteration, or addition to the terms of the contract or to the work to be performed thereunder or the specifications accompanying the same shall in anyway effect its obligations on this bond, and it does hereby waive notice of any such change, extension of time, alteration, or addition to the terms of the contract, to the work or to the specifications.

IN WITNESS WHEREOF, the above bound parties have executed this instrument under their seals this \_\_\_\_ day of \_\_\_\_\_, 20\_\_, the name and corporate party being hereto affixed and these presents duly signed by its undersigned representative, pursuant to authority of its governing body.

\_\_\_\_\_  
\_\_\_\_\_  
Principal

By \_\_\_\_\_  
\_\_\_\_\_

Surety  
By \_\_\_\_\_

# CITY OF SPARKS, NEVADA – Payment Bond – Labor & Materials

Bid #: \_\_\_\_\_

Bond #: \_\_\_\_\_

Surety Rating: \_\_\_\_\_

NV License #: \_\_\_\_\_

Appt. Agent Countersigning - List below with address

KNOW ALL MEN BY THESE PRESENTS: That WHEREAS, the City of Sparks in the State of Nevada, has awarded to **CONTRACTOR**, hereinafter designated as the “Principal” a Contract for Bid # **BID NUMBER**, PWP # **PWP NUMBER**, for the **PROJECT TITLE** and

WHEREAS, said Principal is required under the terms of said contract to furnish a Bond for the faithful and proper performance of the Contract and the Bonding Company has an “A” or better rating with Moody’s or A.M. Best and T-Listed with the U.S. Treasury Department;

NOW, THEREFORE, we, the Principal, and \_\_\_\_\_ as Surety, are held and firmly bound unto the City of Sparks in the State of Nevada, in the penal sum of **WRITTEN AMOUNT** dollars (\$\_\_\_\_\_), lawful money of the United States, being not less than one hundred percent (100%) of the estimated contract cost of the work for the payment of which sum well and truly to be made, we bind ourselves, our heirs, executors, administrators, and successors, jointly and severally firmly by these presents.

NOW, THEREFORE, THE CONDITION OF THIS OBLIGATION IS SUCH that if the above bounden principal, his or its heirs, executors, administrators, successors, or assigns, shall fail to pay for any materials, provisions, provender or other supplies, implements, or machinery used in, upon, for, or about the performance of the work contracted to be done or for any work or labor thereon of any kind, or for amounts due under the Unemployment Compensation Law with respect to such work or labor as required by the provisions of NRS 612, and provided that the claimant shall have complied with the provisions of said law, the Surety hereon will pay for the same within thirty (30) calendar days an amount not exceeding the sum specified in this bond, then the above obligation shall be null and void; otherwise to remain in full force and account. In case suit is brought upon this bond, the said Surety agrees to pay a reasonable attorney’s fees to be fixed by the Court.

The Bond shall insure to the benefit of any and all persons, companies and corporations entitled to file claims under NRS 339 as to give a right of action to them or their assigns in any suit brought upon this Bond.

IN WITNESS WHEREOF, the above bound parties have executed this instrument under their seals this \_\_\_\_ day of \_\_\_\_\_, 20\_\_\_\_, the name and corporate seal of each corporate party being hereto affixed and these presents duly signed by its undersigned representative, pursuant to authority of its governing body.

\_\_\_\_\_  
\_\_\_\_\_  
\_\_\_\_\_  
Principal

By \_\_\_\_\_

\_\_\_\_\_  
\_\_\_\_\_  
\_\_\_\_\_  
Surety

By \_\_\_\_\_

SAMPLE TRAILER RENTAL CONTRACT

**CITY OF SPARKS**  
**Truckee Meadows Water Reclamation Facility**  
**8500 Clean Water Way**  
**Reno, NV 89502**

LESSEE (Full Legal Name & Address)				SUPPLIER		
QUANTITY	MAKE	MODEL	SERIAL #	DESCRIPTION	PRICE	
				Cost		
				Sales Tax		
				Bank Fee		
				Other		
				Cost to Lessor		

Location of Leased Property \_\_\_\_\_  
No. Street City State

Monthly Rent \$ \_\_\_\_\_ Use Tax \$ \_\_\_\_\_ Total Monthly Rent Payment \$ \_\_\_\_\_ Total Rent Payable \$ \_\_\_\_\_  
Regular Payments to  
 Advance Rents \$ \_\_\_\_\_ Security Deposit \$ \_\_\_\_\_ Rent Period of Lease \_\_\_\_\_ mos. Commence Monthly on \_\_\_\_\_  
 Pro-Rate Rents \$ \_\_\_\_\_ For \_\_\_\_\_ days Capitalized Reduction \$ \_\_\_\_\_ Documentation Fee \$ \_\_\_\_\_ Residual \_\_\_\_\_%

**TERMS AND CONDITIONS OF LEASE**

1. **LEASE.** Lessee hereby leases from Lessor and Lessor leases to Lessee the above described property.
2. **LESSEE'S OBLIGATIONS.** Lessee's obligations as to an item of leased property (other than the rental obligation which commences as described in paragraph 3) commence at such time as Lessor has any interest therein or related obligation. The lease term ends upon expiration of the number of months indicated under "Rent Period of Lease" after the due date of the initial regular rent but Lessee's obligations continue until the item is returned to Lessor in accordance with Paragraph 10, except as otherwise provided in this lease.
3. **RENT AND OTHER PAYMENTS.** Rental for the leased property will be deducted from monies owed to Lessee.
4. **SECURITY DEPOSIT.** Lessee will pay the sum specified under "Security Deposit" above upon lease execution, as security for Lessee's compliance hereunder, and not as advance rental. At its option, Lessor may apply the security deposit to cure any default of Lessee hereunder, in which event Lessee shall promptly restore the security deposit to the full amount specified above. If, upon final termination of this lease, Lessee has fulfilled all of the terms and conditions herein provided, Lessor shall pay to Lessee any remaining balance of the security deposit. The security deposit will not bear interest.



5. **INSURANCE.** Lessee will carry (a) all risk insurance on the leased property for not less than full replacement value naming Lessor or Lienholder as Loss Payee and (b) combined single limit liability insurance of not less than \$10000.00 per occurrence, or such greater amount as Lessor may from time to time require on notice to Lessee, naming Lessor as an Additional Insured. The insurance must be in a form and with companies approved by Lessor, must name Lessee as a Name Insured, must provide at least 10 days advance written notice to Lessor of material change or cancellation and must provide that the coverage is "primary." Lessee will cause this insurance to protect any assignee of Lessor of whom Lessee is given notice as such assignee's interests may appear, Lessee will promptly notify all affected parties of any claim under any such policy and will provide each party all requested pertinent data. The proceeds of this insurance, at the option of Lessor, will be applied toward (a) the repair of any applicable leased property, (b) payment of the property's "Casualty Value," as defined in paragraph 13, and/or (c) payment of any accrued obligations of Lessee to Lessor. Lessee hereby appoints Lessor as Lessee's attorney in face to do all things, including, but not limited to, making claims, receiving payments and endorsing documents, checks or drafts, to secure payments due under any policy contemplated hereby on account of a "casualty" as similarly defined. Lessee will cause certificates of insurance evidencing the required coverage to be delivered to Lessor.
6. **OWNERSHIP OF LEASED PROPERTY.** Lessor is the lawful owner of the leased property leased hereunder. Title shall remain in Lessor, or its assigns, at all times. Lessee shall furnish Lessor, upon request, a landlord's waiver and consent to remove all leased property from said landlord's premises at any time during or after the term of this lease. Lessor may display, but is not required to display, notice of its ownership of the leased property by plates, tags, identifying stencil, or other identification. Lessee will not alter or deface any such indicia of ownership and shall maintain such indicia of ownership in good and readable condition. Lessee shall have no right, title or interest in any of the leased property, except the right to peacefully and quietly hold and use the leased property during the lease term as herein provided, unless and until a default shall occur. The leased property is, and shall at all times be and remain, personal property, notwithstanding that the leased property, or any part thereof, may now be, or hereafter become, in any manner affixed or attached to real property.
7. **NET LEASE; NO OFFSET.** This lease is a net lease. Lessee's obligation to pay all rent and all other amounts payable hereunder and to perform lessee's other obligations hereunder shall be absolute, irrevocable and unconditional and shall not be subject to any reduction (except pursuant to a rental adjustment letter executed in connection herewith) or any abatement, set-off, defense, release, counterclaim or recoupment for any reason whatsoever, it being the express intention of Lessor and lessee that all rent and all other payments payable and all other obligations to be performed by lessee hereunder shall be, and continue to be, payable and to be performed in all events unless the obligation to pay or perform the same shall be terminated pursuant to the express provisions of this lease.
8. **LIMITATION OF WARRANTIES AND LIABILITY; FINANCE LEASE TREATMENT UNDER ARTICLE 2A; WAIVER OF ARTICLE 2A AND SIMILAR RIGHTS. LESSEE HAS SELECTED THE LEASED PROPERTY.** Lessor hereby disclaims any representation or warranty, either express or implied, as to any matter whatsoever, including, without limitation, the design or condition of the leased property, its conformity to the provisions and specifications of any purchase order or orders relating thereto or title thereto, it being expressly understood that Lessor is leasing the leased property to lessee as-is. Lessor shall not be liable for any delay in delivery of the leased property or any other matter beyond Lessor's control nor shall Lessor in any event be liable for the incidental or consequential damages. This lease will be treated as a "Finance Lease" within the purview of article 2A of the Nevada commercial code ("article 2A") and thus lessee will be entitled to the promises and warranties Lessor receives under the contract or contracts evidencing Lessor's purchase of the leased property, including any manufacturer or third party warranties. Lessee acknowledges that Lessor hereby advises Lessee to contract the supplier or suppliers of the leased property for a description of those promises and warranties, including any related disclaimers or limitations, including of remedies. Consistent with the assumption by Lessee under this lease of all risks respecting the leased property, Lessee waives any rights, defenses and claims against Lessor related to the leased property arising under article 2A or similar applicable law.
9. **DEFECTS IN LEASED PROPERTY.** If the leased property is unsatisfactory for any reason, Lessee shall make claim on account thereof solely against the manufacturer or supplier, and Lessor agrees to assign to Lessee, solely for the purposes of making and prosecuting such claim against the manufacturer or supplier, all of the rights which Lessor has or may have against the manufacturer or supplier for breach of warranty or representation, or for failure of said manufacturer or supplier to perform in any other manner.
10. **REMOVAL, INSPECTION AND RETURN OF LEASED PROPERTY.** Lessee shall not remove the leased property from the location specified herein under "Location of Leased Property" without the prior written consent of Lessor. Lessor shall have the right, upon reasonable notice to Lessee, and at reasonable times, which include, but are not limited to, Lessee's regular business hours, to inspect the leased property or observe its use that the specified location, or wherever the leased property may be located, and shall have free access to Lessee's premises or said location during delivery or removal of leased property. Lessor may enter upon any premises where the leased property is located and remove the leased property, without notices to Lessee, and without liability therefore, if, in the opinion of Lessor, the leased property

is being improperly used or maintained, or upon terminations of the lease term. Lessee shall promptly advise Lessor of any circumstances which may in any manner adversely affect any item of leased property, or of any attachment or judicial or other process, which may in any way affect Lessor's title thereto. Upon termination or expiration of this lease, Lessee shall, at its own expense, return the leased property, properly packed and crated, to Lessor's address at 8500 Clean Water Way, Reno, Nevada, unless Lessor has specified to Lessee in writing another location to which Lessee is to return the leased property. The leased property shall be returned in the same condition as when received, reasonable wear and tear excepted.

11. **USE, MAINTENANCE, REPAIR AND ALTERATION.** Lessee agrees that it will, at its own expense, (a) keep and maintain the leased property in good condition and working order, and supply and install all replacement parts, accessories, or other devices, when required to maintain the leased property in good working condition, or when required by applicable law, ordinance or regulation, which parts, accessories, or devices shall be and become the sole property of Lessor; (b) use, operate and maintain the leased property for commercial or business purposes in a careful manner in the normal course of business, and only for the purpose for which such leased property was designed, and comply with all laws, ordinances and regulations, insurance policy requirements and manufacturers' instructions and warranty requirements in any manner relating to the ownership, possession, installation, use, operations or maintenance thereof, and obtain all permits or licenses necessary to install, use or operate the leased property; (c) keep the leased property free and clear of all levies, liens and claims not created by Lessor; (d) timely pay all taxes, costs, fees and expenses of every kind and nature, including applicable sales or use taxes, but excluding Lessor's net income taxes, now or hereafter occasioned by, imposed or levied upon, or arising out of the use, possession, ownership, renting, leasing or maintenance of the leased property or this lease, together with any interest or penalties in connection therewith, whether billed to, levied upon, or assessed against Lessor or Lessee; and (e) make no alterations, modifications, additions, subtractions or improvements to leased property which detract from its value or functionality unless required by law or an insurance policy Lessee carries hereunder, without the prior written consent of Lessor, but, if so authorized by Lessor, any such alterations, modifications, additions, subtractions or improvements shall be deemed to be a part of the leased property and shall become the property of Lessor.
12. **LESSEE TO INDEMNIFY LESSOR.** Lessee assumes liability for, and hereby agrees to indemnify, defend, protect and keep harmless Lessor, its agents, employees, officers and directors from and against, any and all liabilities, obligations, losses, damages, costs, actions, suits, expenses (including legal fees), disbursements and claims (including claims based upon strict liability or involving latent defects whether or not discoverable by Lessee or Lessor and patent, trademark and copyright infringement claims) of any kind or nature whatsoever in any way relating to or arising out of this lease or the transactions contemplated by this lease, the rentals, receipts or earnings arising therefrom, or any item of leased property, including the manufacture, selection, purchase, acceptance, delivery, lease, possession, use, operations, maintenance, condition, return, storage or disposition thereof, regardless of where, how and by whom operated, or any failure on the part of Lessee to perform or comply with any condition of this lease. This indemnity includes claims related to property initially contemplated to be leased hereunder, but rejected by Lessee, including claims for the purchase price thereof, and claims related to leased property arising out of events after the expiration or earlier termination of this lease with respect thereto.
13. **LOSS OR DAMAGE TO LEASED PROPERTY.** Lessee shall promptly notify Lessor of any loss, damage, destruction, theft, confiscation or requisition of any leased property. If the property is damaged only and Lessor determines it is repairable, Lessee will promptly have the leased property repaired. If the leased property is damaged and cannot in Lessor's judgment be repaired, or is destroyed, lost, stolen, confiscated, requisitioned, permanently rendered unfit for any reason whatsoever or suffers a constructive loss as defined in an insurance policy carried hereunder (any such occurrence being referred to as a "casualty"), Lessor may declare due and Lessee shall pay to Lessor, as the "Casualty Value" of such property, an amount equal to the sum of (a) all then due to past due amounts under this lease, (b) the unpaid balance of total rent for the property discounted to present value at 6.0% per annum from the dates the rent would have otherwise been due to the first of the succeeding month plus (c) an amount equal to the "Residual" for the property as set forth above discounted to present value at 6.0% per annum from the end of the lease term to the same date. Following payment of the Casualty Value of property which has suffered a casualty, Lessor shall transfer such property to Lessee or Lessee's insurance carrier on an As-Is, Where-Is basis without recourse, representation or warranty, express or implied. Any proceeds received by Lessor under an insurance policy maintained by Lessee hereunder with respect to property suffering a casualty shall be applied to Lessee's obligations hereunder with Lessee remaining liable for any deficiency.
14. **LESSOR PAYMENTS.** If Lessee fails to pay any amount due hereunder or to perform any of its obligations hereunder, Lessor may, at its option but without any obligation to do so, pay such amount or perform such obligation, and Lessee shall reimburse Lessor such payment or the cost of such performance.
15. **DEFAULT BY LESSEE.** This lease will be in default if (a) Lessee fails to pay any rent or other amount due hereunder within 10 days after the same shall become due; (b) Lessee fails to maintain insurance for any leased property as

required by paragraph 5 or Lessee fails to return to any leased property as required by paragraph 10; (c) Lessee attempts to remove, sell, transfer, encumber, part with possession of, assign the lease as to or sublet any leased property without Lessor's consent; (d) Lessee fails to perform or observe any other covenant, condition or agreement to be performed or observed by it under this lease, any agreement, document or certificate delivered by Lessee in connection herewith or any other agreement under which Lessee has obligations to Lessor; (e) any representation or warranty made by Lessee or by a guarantor in any document furnished by Lessee or the guarantor in connection herewith shall prove to have been incorrect in any material respect when such representation or warranty was made or given; (f) dissolution, cessation of business activities or winding up of the affairs of Lessee or a guarantor or death or declaration of incompetency of Lessee or a guarantor if an individual; (g) a petition in bankruptcy or for reorganization or arrangement shall by or against Lessee or a guarantor, or Lessee or a guarantor shall make an assignment for the benefit of creditors or consent to the appointment of a trustee or a receiver, or a trustee or a receiver shall be appointed for Lessee or a guarantor, or for any leased property, or for a substantial part of Lessee's or a guarantor's property, and, if involuntary, such proceeding, trustee or receiver shall not be dismissed within a period of 45 days; or (h) there is a transfer of effective control of Lessee, if an organization. Upon the occurrence of any default, Lessor may, at its option, declare this lease to be in default by notice to such effect given to Lessee, at any time thereafter Lessor may, as Lessor in its sole discretion shall elect, as to some or all leased property (a) proceed by appropriate court action, either at law or in equity, to enforce performance by Lessee of the applicable covenants of this lease or to recover all then or past due payments and other damages, and/or (b) by notice in writing terminate this lease, whereupon all rights of Lessee to the use of the leased property shall absolutely cease and terminate and Lessee shall, at its expense, promptly return the leased property to the possession of Lessor at such place as Lessor shall designate and in the condition required upon the return thereof pursuant to this lease and Lessor, at its option, may enter upon the premises where the leased property is located and take immediate possession of and remove the same by self-help proceedings or otherwise. Following such termination Lessee shall pay to Lessor, as liquidated damages for the loss of a bargain and not as a penalty, an amount equal to the excess, if any, of (i) the Casualty Value of the leased property over (ii) an amount equal to the net proceeds to present value at 6.0% per annum and deducting re-lease costs. Lessee shall also pay Lessor interest on the unpaid balance of the amount determined above as indicated in and at the rate set forth in paragraph 3 hereof. Lessee shall be liable for all costs, charges and expenses, including court costs, attorneys' fees, repossession costs and refurbishment expenses, incurred by Lessor by reason of the occurrence of any default, the exercise of Lessor's remedies with respect thereto or any other action related to this lease, including any bankruptcy or insolvency proceeding. No remedy referred to herein is intended to be exclusive, but each shall be cumulative and in addition to any other remedy referred to above or otherwise available to Lessor. No failure on the part of Lessor to exercise, and no delay in exercising, any right or remedy preclude any other or further exercise of the same or any other right or remedy.

16. **SUBLEASE; ASSIGNMENT.** Lessee shall not without Lessor's prior written consent sublet or otherwise relinquish possession of any leased property, assign any of its rights hereunder, permit any other party to use any leased property or create or allow any lien or encumbrance not created by Lessor to attach to any leased property or Lessee's rights under this lease. Lessor or its assignees may assign, sell or encumber all or any part of this lease, the leased property and the rent payments hereunder, and Lessee hereby consents to all such assignments and pledges. In the event of any such assignment of rental payments hereunder and written notice thereof to Lessee, Lessee agrees unconditionally to pay directly to the assignee all rent and other sums specified in the notice which are due to become due under this lease. The rights of any such assignee shall not be subject to any defense, counterclaim or set-off which Lessee may have against Lessor or any other party.
17. **NOTICES.** All communications and notices provided for herein shall be in writing and shall become effective when deposited in the United States mail, with proper postage for first-class mail prepaid, addressed to Lessor or Lessee, as appropriate, at the respective address set forth above, or at such other address as Lessor or Lessee may from time to time give the other by notice given in accordance herewith.
18. **FURTHER ASSURANCES.** Lessee shall promptly obtain, execute and/or deliver to Lessor such further documents, including, without limitation, financial statements, financing statements, real property waivers and notices of assignment as Lessor may request to carry out the intent of this lease. Such financing statements shall not be interpreted as acknowledging this lease is a "lease intended as a financing," and this lease shall at all times be considered a lease of the leased property from Lessor to Lessee.
19. **JURY TRIAL WAIVER.** Lessor and Lessee hereby waive any right to a trial by jury in any action related to this lease.
20. **GENERAL PROVISIONS.** This lease and all agreements, covenants, representations and warranties in any other certificate or document delivered by Lessee in connection herewith shall be binding upon and inure to the benefit of Lessor and Lessee and their respective successors, assigns, personal representatives, heirs and legatees. This lease constitutes the entire agreement of the parties as to the leasing of the leased property. The terms of this lease shall not be waived, altered, modified, amended or supplemented in any manner whatsoever except by a written instrument signed by the party to be held responsible. All agreements, indemnities, obligations, representations and warranties in this lease

or in any document or certificate delivered pursuant hereto or in connection herewith shall survive execution and delivery of this lease and the expiration or other termination of this lease. Lessee acknowledges that neither any manufacturer, vendor, retailer, distributor or wholesaler whom Lessee has selected to sell the leased property nor any lease broker with whom Lessee may have dealt is an agent, servant or employee of Lessor and that Lessor is not bound by any statement of any such party which may be contrary to the terms of this lease. This lease shall be construed in accordance with, and shall be governed by, the laws of the State of Nevada. Any provision of this lease which is prohibited or unenforceable in any jurisdiction shall be ineffective as to such jurisdiction to the extent of such prohibition or unenforceability without invalidating any other provision. Paragraph headings are solely for the convenience of the parties and are not an aid in the interpretation of this lease. Time is of the essence of each provision of this lease. Lessee authorizes Lessor from time to time to obtain credit agency reports and to make other inquiries respecting Lessee, including contacting trade references. Lessee further authorizes Lessor to provide such information, and to report on Lessor's business relationships with Lessee, to others.

21. **USE OF LEASED PROPERTY.** Leased property shall be used for the exclusive purpose of waste removal from TMWRF.

Lessee warrants that Lessee had read all terms and conditions of this lease, and specifically agrees to all the terms and conditions set forth in this lease, and executes this lease with the intent that Lessor shall rely thereon. Except as contemplated in a rental adjustment letter executed in connection herewith, Lessee's execution of this lease constitutes Lessee's acceptance of the leased property for all purposes hereof and request to Lessor to pay the "Cost to Lessor" shown above (excluding the bank fee) to the supplier(s). This lease will be effective only upon Lessor's execution hereof, and by Lessor's execution hereof Lessor agrees to lease the leased property to Lessee and to make such payment.

**GUARANTORS SIGN HERE:**

The undersigned, jointly and severally, hereby unconditionally guaranty and warrant the full and complete payment and performance of the above lease in accordance with the terms thereof, and any and all renewals, continuations, modifications, extensions, compromises, supplements and amendments thereof, without deduction by reason of set off, defense or counterclaim. Notice of acceptance hereof, and all notices of any kind to which we may be entitled, are hereby waived. The liability of each of the undersigned is direct and unconditional, and may be enforced without requiring Lessor to first resort to any other right, remedy discharge or satisfy our joint and several liability hereunder except the full performance and payment of the above lease.

(Guarantor) \_\_\_\_\_

Date: \_\_\_\_\_

(Guarantor) \_\_\_\_\_

Date: \_\_\_\_\_

City of Sparks (Lessor)

By: \_\_\_\_\_

By: \_\_\_\_\_

By: \_\_\_\_\_

Authorized Signature