

BID FOR
2024 CITY OF SPARKS PEDESTRIAN RAMP REPLACEMENT
PROJECT – FEDERALLY FUNDED

BID # 24/25-001

PWP # WA-2025-008

FEDERAL PROJECT #SI-0032-(381)

NDOT PROJECT #61185

BIDS DUE NOT LATER THAN: 1:45 PM ON OCTOBER 16, 2024

PUBLIC BID OPENING: 2:00 PM ON OCTOBER 16, 2024

[NOTE: TIME BIDS ARE DUE IS DIFFERENT FROM BID OPENING TIME]



431 PRATER WAY
P.O. BOX 857
SPARKS, NV 89432-0857

Company Name: _____

**CITY OF SPARKS
NOTICE TO BIDDERS
2024 CITY OF SPARKS PEDESTRIAN RAMP REPLACEMENT PROJECT –
FEDERALLY FUNDED
BID # 24/25-001 / PWP # WA-2025-008
FEDERAL PROJECT #SI-0032-(381)
NDOT PROJECT #61185**

NOTICE IS HEREBY GIVEN that the City of Sparks, Nevada, will receive written sealed bids only, for the project listed above. Said bids must be in the hands of the Contracts and Risk Manager at 431 Prater Way, Sparks, Nevada, **NO LATER THAN 1:45 PM ON OCTOBER 16, 2024**. Bids postmarked prior to, but not received until after this deadline will not be accepted. Vendor bid response submittals may not be sent to the City of Sparks via the Internet/e-mail and will not be entertained for award by the City of Sparks. The right is reserved to reject any Bid/Proposal or to accept the Bid/Proposal which is deemed by the City of Sparks to be in the best interest of the City of Sparks. The City of Sparks reserves the right to waive any irregularities and/or informalities in the bid process.

All Bids are to be marked clearly on the outside. Due to hybrid schedules and staff reductions, in-person staff availability is limited. Bidders wishing to physically deliver their bids on the bid due date shall note that the Purchasing Office will receive bids in the lobby of City Hall beginning at 1PM on October 16, 2024. Bids are due no later than 1:45PM. Bids may also be delivered to the Purchasing Department physical dropbox/mailbox, also located in the lobby of City Hall.

Bids will be opened and publicly read at **2:00 PM ON OCTOBER 16, 2024** via Zoom video/audio conferencing. Meeting # 876 2708 5893. Meeting Passcode: 312411with a direct link of:
<https://cityofsparks-us.zoom.us/j/87627085893?pwd=CH4YFOc0jKza4hCaZzw7s9CTFREsgB.1>

PROJECT DESCRIPTION: The work includes but is not limited to, removal and replacement of curb, gutter sidewalk, valley gutter spandrels and ADA ramps and other miscellaneous associated work activities necessary to complete the project as stated in the plans and bid specifications.

This is a Federal-aid contract and the requirements for such shall apply. On a Federal-aid contract, any Contractor otherwise qualified by the State of Nevada to perform such work is not required to be licensed nor to submit application for license in advance of submitting a bid or having such bid considered, provided, however, that such exception does not constitute a waiver of the City's right under its license laws to require a Contractor, determined to be a successful bidder, to be licensed to do business in the State of Nevada and the City of Sparks in connection with the award of the contract to them.

BONDING/LICENSING: A Bid Bond in the amount of 5% of bid amount is required. This bid bond will function as a penalty in the event the successful bidder fails to enter into a written contract with the City in accordance with the bid documents. Additionally, the City will be entitled to actual damages, if any. Prospective bidders will be required to have a current Contractor's License under the Nevada State Law for the type of work specified herein.

The work to be performed under this Contract shall be commenced by the successful Bidder after all executed Contract documents have been submitted, and after being notified to proceed by the City of Sparks.

Bid documents and specifications may be obtained from the City of Sparks website. Please visit <http://portal.cityofsparks.us/bids> to obtain complete bid documents. There is no cost to use the system or obtain plans, but registration at the site is required. It is the responsibility of all potential bidders/responders to monitor the Purchasing Division's website for any changing information prior to submitting their bid/proposal. The City of Sparks will not be responsible for the timeliness or completeness of information provided by any 3rd party bid listing or re-selling service. For further information, contact the individual responsible for coordinating this bid:
Amber Sosa, P.E. – City Engineer @ asosa@cityofsparks.us.

Reno Gazette Journal Legal Notices Section
Publish Date: September 25, 2024
Proof of publication required

Bidder's Checklist

Bidders are instructed to complete and return the following forms in order for their bids to be complete. Failure to return the following items may result in your bid being declared “non-responsive.”

1. _____ Bid Item Schedule
2. _____ Bidder Information Sheets
3. _____ Subcontractor Information Form (5% list due with bid submittal)
4. _____ Acknowledgement and Execution Form
5. _____ Certification Regarding Debarment
6. _____ Bid Bond
7. _____ Signed Bid Addenda (if applicable)
8. _____ Completed Federal Forms/Disclosures

**CITY OF SPARKS
 BID ITEM SCHEDULE**

**BID TITLE 2024 CITY OF SPARKS PEDESTRIAN RAMP REPLACEMENT
 PROJECT-FEDERALLY FUNDED**

**BID #24/25-001, PWP#WA-2025-008
 FEDERAL PROJECT # SI-0032-(381)
 NDOT PROJECT #61185**

PRICES must be valid for 90 calendar days after the bid opening.

COMPLETION of this project is expected **PURSUANT TO CONTRACT DOCUMENTS.**

BIDDER acknowledges receipt of _____ Addenda.

 Bidder Name

 (signature)

Refer to Special Technical Section for a map depicting the street locations and plan sheets provided

Item No.	Quantity	Unit	Description	Unit Price	Total Price
1	630	LF	Remove Existing and Construct PCC Type 1 Curb and Gutter, complete and in place.	\$ _____ /LF	\$ _____
2	2,330	SF	Remove Existing and Construct PCC Sidewalk, complete and in place.	\$ _____ /SF	\$ _____
3	550	SF	Remove Existing and Construct PCC Valley Gutter Spandrel, complete and in place.	\$ _____ /SF	\$ _____
4	50	EA	Remove Existing and Construct PCC ADA Accessible Ramp, complete and in place.	\$ _____ /EA	\$ _____
5	1	EA	Remove and Relocate Sign and Post, complete and in place.	\$ _____ /EA	\$ _____
6	300	LF	Remove and Reinstall Fencing, complete and in place. (Contingent Item)	\$ _____ /LF	\$ _____
7	1	LS	Force Account	\$25,000.00	\$25,000.00
Total Price for 2024 CITY OF SPARKS PEDESTRIAN RAMP REPLACEMENT PROJECT-FEDERALLY FUNDED \$ _____ (written total bid price)				\$ _____	

Bidder Information

COMPANY INFORMATION:

Company Name:
Contact Name:
Address:
City:
State / Zip Code:
Telephone Number including area code:
Fax Number including area code:
E-mail:

COMPANY BACKGROUND

- 1) Has your company ever failed to complete any contracts awarded to it? No ___ Yes ___ (If yes, please provide details.)

- 2) Has your company filed any arbitration request or law suits on contracts awarded within the last five years? No ___ Yes ___ (If yes, please provide details.)

- 3) Does your company now have any legal suits or arbitration claims pending or outstanding against it or any officers relating to the performance of a public contract? No ___ Yes ___ (If yes, please provide details.)

- 4) Does your company now employ any officers or principals who were with another firm when that company failed to complete a contract within the last five years? No ___ Yes ___ (If yes, please provide details.)

- 5) Has your company had a contract partially or completely terminated for default (cause) within the past five years? No ___ Yes ___ (If yes, please provide details.)

- 6) Has your company been found non-responsible on a government bid within the last five years? No ___ Yes ___ (If yes, please provide details.)

Bidder Information

CONTRACTOR LICENSE INFORMATION:

Nevada State Contractor's License Number (If Applicable):
License Classification(s):
Limitation(s) of License:
Date Issued:
Date of Expiration:
Name of Licensee:
City, State, Zip Code of Licensee:
Telephone Number of Licensee:

BUSINESS LICENSING INFORMATION All vendors doing business within the City of Sparks are required to obtain and maintain a current business license from the City of Sparks prior to commencement of work (Sparks Municipal Code Section 5.08.020A). Vendor(s) awarded a contract resulting from this bid shall be required to obtain a current business license if they do not already hold one.

City of Sparks Business License Number:
Date Issued:
Date of Expiration:
Name of Licensee:
City, State, Zip Code of Licensee:
Telephone Number of Licensee:
Taxpayer Identification Number:

Bidder Information

DISCLOSURE OF PRINCIPALS:

a) Individual and/or Partnership:

Owner 1) Name:
Address:
City, State, Zip Code:
Telephone Number:
Owner 2) Name:
Address:
City, State, Zip Code:
Telephone Number:
Other 1) Title:
Name
Other 2) Title:
Name:

b) Corporation:

State in which Company is Incorporated:
Date Incorporated:
Name of Corporation:
Address
City, State, Zip Code:
Telephone Number:
President's Name:
Vice-President's Name:
Other 1) Name:
Title:

Awarded Contract Information

If your company is determined to be the awardee of the contract for this scope of work, the contract form for the work will be routed via electronic means. Therefore, please identify the authorized individual that will be signing the resulting contract. Presumably this will be the company owner or corporate officer authorized to bind the company for future work.

COMPANY INFORMATION:

Company Name:
Authorized Name:
Title:
Individual E-Mail Address:
Telephone Number including area code:
Mailing Address:

**SUBCONTRACTOR DETAIL
SUBCONTRACTORS EXCEEDING FIVE PERCENT OF BID AMOUNT**

INSTRUCTIONS: Per NRS 338.141, Bidder submits the following names of First-Tier Subcontractors who will provide to Bidder labor or a portion of the Work or improvements for which Subcontractor will be paid an amount exceeding five percent (5%) of the Bid Price. The Bidder shall list the name of a Subcontractor for each portion of the Work, the value of which exceeds five percent (5%) of the Bid Price. **If Bidder will perform more than 5% of the Work, BIDDER SHALL ALSO LIST HIS NAME and description of the work that the prime contractor will perform in the space provided below.**

Name of Subcontractor	Address	
Phone	Nevada Contractor License #	Limit of License
Description of Work:		
Name of Subcontractor	Address	
Phone	Nevada Contractor License #	Limit of License
Description of Work:		
Name of Subcontractor	Address	
Phone	Nevada Contractor License #	Limit of License
Description of Work:		
Name of Subcontractor	Address	
Phone	Nevada Contractor License #	Limit of License
Description of Work:		
Name of Subcontractor	Address	
Phone	Nevada Contractor License #	Limit of License
Description of Work:		
Name of Subcontractor	Address	
Phone	Nevada Contractor License #	Limit of License
Description of Work:		

Bidder Name: _____

Authorized Signature: _____

SUBCONTRACTOR DETAIL
SUBCONTRACTORS EXCEEDING ONE PERCENT OF BID AMOUNT OR \$50,000

INSTRUCTIONS: In compliance with NRS 338.141, Bidder submits the following names of First-Tier Subcontractors who will provide to Bidder labor or a portion of the Work or improvements for which Subcontractor will be paid an amount exceeding one percent (1%) of the Bid or \$50,000, whichever is greater.

Since all Subcontractors listed on the Bidder's 5% Subcontractor Information Form are over 1% of the Bid amount, those Subcontractors shall automatically be deemed incorporated into this 1% Subcontractor Information form and need not be re-listed below.

Information provided must be submitted within two (2) hours after the completion of the opening of the bids (Per NRS 338.141). Bidder shall enter "NONE" under "Name of Subcontractor" if not utilizing subcontractors exceeding this amount. This form must be complete in all respects. If, additional space is needed, attach a separate page. The bidder may elect to submit this information with the bid proposal and, in that case, the bidder will be considered as having submitted this information within the above two hours.

Name of Subcontractor	Address	
Phone	Nevada Contractor License #	Limit of License
Description of Work:		
Name of Subcontractor	Address	
Phone	Nevada Contractor License #	Limit of License
Description of Work:		
Name of Subcontractor	Address	
Phone	Nevada Contractor License #	Limit of License
Description of Work:		
Name of Subcontractor	Address	
Phone	Nevada Contractor License #	Limit of License
Description of Work:		

Bidder Name: _____ **Authorized Signature:** _____

CITY OF SPARKS ACKNOWLEDGMENT AND EXECUTION:

STATE OF _____)
) SS
County of _____)

_____(Name of Principal) being first duly sworn, deposes and says: That he/she is the Bidder, or authorized agent of the Bidder for whom the aforesaid described work is to be performed by; that he/she has read the Plans, Specifications, and related documents including but not limited to, any addenda issued and understands the terms, conditions, and requirements thereof; that if his/her bid is accepted that he/she agrees to furnish and deliver all materials except those specified to be furnished by the City of Sparks (Owner) and to do and perform all work for the **2024 CITY OF SPARKS PEDESTRIAN RAMP REPLACEMENT PROJECT – FEDERALLY FUNDED, Bid # 24/25-001**, together with incidental items necessary to complete the work to be constructed and/or services to be provided in accordance with the Specifications, Plans, and Contract Documents annexed hereto.

TO THE CONTRACTS AND RISK MANAGER OF THE CITY OF SPARKS:

The undersigned, as Bidder, declares that the only persons or parties interested in this proposal, as principals, are those named herein, the Bidder is fully informed respecting the preparation and contents of the attached Bid and of all pertinent circumstances respecting such Bid: that this proposal is made without collusion with any other person, firm or corporation; that he/she has carefully examined the location of the proposed work; the proposed form of Contract, the Contract Provisions, Plans, Specifications and Contract Documents incorporated therein referred to and made part thereof; that he/she proposes and agrees if this proposal is accepted, that he/she will contract with the City of Sparks in the form of the Contract prescribed, to provide all necessary machinery, tools, apparatus and other means of construction, and to do all the work and furnish all the materials specified in the Contract and annexed Contract Provisions, Plans and Specifications, in the manner and time prescribed and according to the requirements of the Project Representative as therein set forth, it being understood and agreed that the quantities shown herein are approximate only and are subject to increase or decrease, and that he/she will accept, in full, payment therefore the indicated prices.

(Printed Name of Contractor/Bidder) Contractor/Bidder: _____
BY: _____
Firm: _____
Address: _____
City: _____
State / Zip Code: _____
Telephone Number: _____
Fax Number: _____
E-mail Address: _____
(Signature of Principal) Signature: _____
DATED this _____ day of _____, 2023.

State of Nevada)
) SS.
County of _____)

On this _____ day of _____, in the year 2023, before me,

_____/Notary Public, personally appeared _____ Personally known to me (or proved
to me on the basis of satisfactory evidence) to be the person whose name is subscribed to this instrument, and acknowledged that he (she) executed it. WITNESS my hand and official seal.

Notary's Signature: _____ My commission Expires: _____

**CERTIFICATION REGARDING DEBARMENT, SUSPENSION, AND OTHER
RESPONSIBILITY MATTERS**

(This form to be signed and returned at the time of bid)

This certification is required by the Federal Regulations Implementing Executive Order 12549, Debarment and Suspension, 45 CFR Part 93, Government-wide Debarment and Suspension, for the Department of Agriculture (7 CFR Part 3017), Department of Labor (29 CFR Part 98), Department of Education (34 CFR Parts 85, 668, 682), Department of Health and Human Services (45 CFR Part 76).

The prospective bidder, _____ certifies to the best of its knowledge and belief that it and its principals:

- (a) Are not presently debarred, suspended, proposed for debarment, declared ineligible, or voluntarily excluded from covered transactions by any Federal department or agency;
- (b) Have not within a three year period preceding this proposal been convicted of or had a civil judgment rendered against them for commission of fraud or a criminal offense in connection with obtaining, attempting to obtain, or performing a public (Federal, State, or local) transaction or contract under a public transaction; violation of Federal or State antitrust statutes or commission of embezzlement, theft, forgery, bribery, falsification or destruction of records, making false statements, or receiving stolen property;
- (c) Are not presently indicted for or otherwise criminally or civilly charged by a government entity (Federal, State, or local) with commission of any of the offenses enumerated in paragraph (b) of this certification; and
- (d) Have not within a three-year period preceding this application/proposal had one or more public transactions (Federal, State, or local) terminated for cause or default.

I understand that a false statement on this certification may be grounds for rejection of this proposal or termination of the award. Any exceptions provided will not necessarily result in denial of award, but will be considered in determining bidder responsibility and whether or not the City will enter into contract with the party. For any exception noted, indicate on an attached sheet to whom it applies, initiating agency, and dates of action. Providing false information may result in criminal prosecution or administrative sanctions.

Typed Name & Title of Authorized Representative

Signature of Authorized Representative

Date

I am unable to certify to the above statement. My explanation is attached.

Signature _____ Date _____

CITY OF SPARKS, NEVADA – 5% Bid Bond

KNOW ALL MEN BY THESE PRESENTS: That we the undersigned _____, as “Principal,” and _____, as “Surety,” are hereby held and firmly bound unto the City of Sparks, Nevada, as “Obligee,” in the penal sum of _____ dollars (\$_____) for the payment of which, well and truly to be made, the Principal and Surety bind themselves, their heirs, executors, and administrators, successors and assigns, jointly and severally, by this instrument. The condition of the obligation of this bid bond is as follows:

WHEREAS, NRS 332.105 authorizes local governments to require bid bonds to insure execution and proper performance of the Contract and the Bonding Company has an “A” or better rating with Moody’s or A.M. Best and T-Listed with the U.S. Treasury Department;

AND, WHEREAS, the Principal has submitted a bid for Bid # **24/25-001** PWP # **WA-2025-008**, for the **2024 CITY OF SPARKS PEDESTRIAN RAMP REPLACEMENT PROJECT – FEDERALY FUNDED.**

NOW, THEREFORE,

- (a) If said Bid shall be rejected; or
- (b) If said Bid shall be accepted and the Principal shall execute and deliver the contract in the bid documents (“Contract”) to Obligee in accordance with the terms of the bid documents, and give such bond or bonds as may be specified in the bid or contract documents with good and sufficient surety for the faithful performance of such Contract and for the prompt payment of labor and material furnished in the prosecution thereof; or
- (c) If the Principal shall pay to the Obligee the full amount of the bid bond as a penalty irrespective of the Obligee’s actual damages in the event of the failure of the Principal to enter into such Contract and give such bond or bonds,

then, this obligation shall be null and void. Otherwise it shall remain in full force and effect, it being expressly understood and agreed that the liability of the Surety (but not of the Principal) for any and all claims hereunder shall, in no event, exceed the penal amount of the obligation as herein stated.

The Surety, for the consideration for which this bond was executed, hereby stipulates and agrees that the obligations of said Surety and its bond shall be in no way impaired or affected by any extension of the time within which the Obligee may accept such bid, and hereby waives notice of any such extension.

IN WITNESS WHEREOF, the Principal and the Surety have hereunto set their hands and the Surety has caused their seal to be hereto affixed and these present to be signed by their proper officers.

Signed, Sealed and dated: _____

Principal
By: _____

Surety
By: _____

GENERAL CONDITIONS

General Conditions



GENERAL CONDITIONS

*Please Read Carefully
These Provisions Are a Part of Your Bid and any Contract Awarded*

Scope of Bid/Proposal: Bids/Proposals are hereby requested for **2024 CITY OF SPARKS PEDESTRIAN RAMP REPLACEMENT PROJECT – FEDERALLY FUNDED**, as per specifications herein.

The bidder agrees that:

- A. Bidder has carefully examined the specifications, and all provisions relating to the item(s) to be furnished or the work to be done; understands the meaning, intent, and requirements; and
- B. Bidder will enter into a written contract and furnish the item(s) or complete the work in the time specified, and in strict conformity with the City of Sparks specifications for the prices quoted.

Note: Bidder is defined as any individual, partnership, or corporation submitting a bid, proposal, or quotation in response to a request for bid (RFB), request for proposal (RFP), request for information (RFI) or request for quotation (RFQ). A bidder may also be referred to as a bidder, contractor, supplier or vendor.

The use of the title “Bidder;,” “Vendor,” “Contractor” or “Consultant” within this solicitation document and any resulting contract shall be deemed interchangeable and shall refer to the person or entity with whom the City of Sparks is soliciting and/or contracting for the service or product referenced within the bid document.

1. Prices:

All prices and notations must be in ink or typewritten. Mistakes may be crossed out and corrections typed or written with ink adjacent to the error. Bids shall indicate the unit price extended to indicate the total price for each item bid. Any difference between the unit price correctly extended and the total price shown for all items bid shall be resolved in favor of the unit prices. Bidders are encouraged to review all prices prior to bid submittal, as withdrawal or correction may not be permitted after the bid has been opened.

2. Firm Prices:

Prices on bid shall be firm prices not subject to escalation unless otherwise provided for in the specifications. In the event the specifications provide for escalation, the maximum limit shall be shown, or the bid shall not be considered. In the event of a decline in market price below a price bid, the City of Sparks shall receive the benefit of such decline.

3. Items Offered:

If the item offered by the bidder has a trade name, brand and/or catalog number, such shall be stated in the bid. If the bidder proposes to furnish an item of a manufacturer or vendor other than that mentioned on the face hereof, bidder must specify maker, brand, quality, catalog number, or other trade designation. Unless such is noted on the bid form, it will be deemed that the item offered is that designated even though the bid may state “or equal”.

4. Brand Names:

Whenever reference to a specific brand name is made by the City, it is intended to describe a component that has been determined to best meet operational, performance, or reliability standards of the City, thereby incorporating these standards by reference within the specifications. These specifications are not meant to limit the vendor; they are guidelines to minimum qualifications. The bidder shall indicate their compliance or non-compliance for each line of the specification. Any deviations from the specifications or where submitted literature does not fully support the meaning of the specifications must be clearly cited in writing by the bidder.

General Conditions



An equivalent (“or equal”) may be offered by the bidder, subject to evaluation and acceptance by the City. It is the bidder’s responsibility to provide, at bidder’s expense, samples, test data, or other documentation the City may require to fully evaluate and determine acceptability of an offered substitute. The City reserves the sole right to reject a substituted component that will not meet or exceed City standards.

5. Samples:

Samples may be required for bid evaluation and testing purposes. Bidders shall agree to provide samples upon request and at no additional cost to the City.

6. Withdrawal of Bids:

Bids may be withdrawn by written or facsimile notice received prior to the exact hour and date specified for receipt of bid. A bid may also be withdrawn in person by a bidder, or bidder’s authorized representative, prior to the exact hour and date set for receipt of bids. Telephone withdrawals are not permitted.

7. Late Bids, Modifications, or Withdrawals:

Bids, modifications of bids, or bid withdrawals received after the exact time and date specified for receipt will not be considered.

8. Mistake in Bid:

- (a) If the bidder discovers a mistake in bid prior to the hour and date specified for receipt of bid, bidder may correct the mistake by withdrawing the bid in accordance with Item 7 above and resubmit prior to the stated bid deadline.
- (b) If within seventy-two hours of the bid closing and prior to the issuance of a purchase order or a contract, the apparent low bidder discovers a mistake in bid of a serious and significant nature, bidder may request consideration be given to withdrawing the bid. The mistake must be evident and provable. The right is reserved by the City to reject any and all requests for withdrawal of bids. The decision of the Purchasing Manager is final as regards acceptance or rejection of requests for withdrawal after closing of bids.
- (c) A mistake in bid cannot be considered once a purchase order or contract is issued.

9. Signature:

All bids shall be signed and the title and firm name indicated. A bid by a corporation shall be signed by an authorized officer, employee or agent with his or her title.

10. Exceptions:

A bidder deviating from specifications must specify any and all deviation(s). Failure to note said exceptions shall be interpreted to convey that the bidder shall propose to perform in the manner described and/or specified in this bid solicitation. If exception(s) are taken or alternatives offered, complete descriptions must be shown separately.

11. Confidential Information:

Any information deemed confidential or proprietary should be clearly identified by the bidder as such. It may then be protected and treated with confidentiality only to the extent permitted by state law. Otherwise the information shall be considered a public record. Information or data submitted with a bid will not be returned.

12. Quality:

Unless otherwise required in the specifications, all goods furnished shall be new and unused.



13. Litigation Warranty:

The bidder, by bidding, warrants that bidder is not currently involved in litigation or arbitration concerning the materials or bidder's performance concerning the same or similar material or service to be supplied pursuant to this contract of specification, and that no judgments or awards have been made against bidder on the basis of bidder's performance in supplying or installing the same or similar material or service, unless such fact is disclosed to the City in the bid. Disclosure may not disqualify the bidder. The City reserves the right to evaluate bids on the basis of the facts surrounding such litigation or arbitration and to require bidder to furnish the City with a surety bond executed by a surety company authorized to do business in the State of Nevada and approved by The City of Sparks in a sum equal to one hundred percent (100%) of the contract price conditional on the faithful performance by bidder of the contract in the event the bid is awarded to bidder, notwithstanding the litigation or arbitration.

14. Royalties, Licenses and Patents:

Unless otherwise specified, the bidder shall pay all royalties, license and patent fees. The bidder warrants that the materials to be supplied do not infringe any patent, trademark or copyright and further agrees to defend any and all suits, actions and claims for infringement that are brought against the City, and to defend, indemnify and hold harmless the City from all loss or damages, whether general, exemplary or punitive, as a result of any actual or claimed infringement asserted against the City, the bidder or those furnishing material to bidder pursuant to this contract.

15. Performance Standards:

Performance of work and acceptability of equipment or materials supplied pursuant to any contract or award shall be to the satisfaction and full discretion of the City.

16. Americans with Disabilities Act (ADA) Standards:

Bidders shall be required to comply with current ADA Standards in preparing their bids and executing work required under any contract resulting from this bid. Completed work must comply with current ADA Standards.

17. Warranties:

(a) Unless otherwise specified, all workmanship, material, labor or equipment provided under the contract shall be warranted by bidder and/or manufacturer for a minimum of twelve (12) months after acceptance by City. Greater warranty protection will be accepted. Lesser warranty protection must be indicated by bidder on the bid proposal as an exception.

(b) Bidder shall be considered primarily responsible to the City for all warranty service, parts and labor applicable to the goods or equipment provided by bidder under this bid or award, irrespective of whether bidder is an agent, broker, fabricator or manufacturer's dealer. Bidder shall be responsible for ensuring that warranty work is performed at a local agency or facility convenient to City and that services, parts and labor are available and provided to meet City's schedules and deadlines. If required and defined within the Scope of Work, the Bidder will post a performance bond after contract award to guarantee performance of these obligations. Bidder may establish a service contract with a local agency satisfactory to City to meet this obligation if bidder does not ordinarily provide warranty service.

18. Addenda:

The effect of all addenda to the bid documents shall be considered in the bid, and said addenda shall be made part of the bid documents and shall be returned with them. Before submitting a bid, each bidder shall ascertain

General Conditions



whether or not any addenda have been issued, and failure to acknowledge any such addenda may render the bid invalid and result in its rejection.

All potential bidders are responsible for monitoring the City website regarding the availability of new bid documents or addenda (where applicable). The City of Sparks will not be responsible for the results of any potential failures in automatic notification systems to potential bidders or plan holders with respect to these documents and will not adjust bid schedules or requirements due to any potential failures of those systems. It is the responsibility of all potential bidders/responders to monitor the Purchasing Division's website for any changing information prior to submitting their bid/proposal. The City of Sparks will not be responsible for the timeliness or completeness of information provided by any 3rd party bid listing or re-selling service.

19. Specifications to Prevail:

The detailed requirements of the Specifications, Scope of Work or Special Conditions shall supersede any conflicting reference in these General Conditions or the stated language on the City of Sparks Standard Purchase Order that are in conflict therewith.

20. Taxes:

The City is exempt from State, City and County Sales Taxes per NRS 372.325. The City will furnish Exemption Certificates for Federal Excise Tax when applicable. The successful bidder shall pay all taxes, levies, duties and assessments of every nature, which may be applicable to any work or materials under this Contract. The Contract Sum and any agreed variations thereof shall include all taxes imposed by law. The successful bidder shall make any and all payroll deductions required by law. The successful bidder herein indemnifies and holds the City harmless from any liability on account of any and all such taxes, levies, duties, assessments and deductions.

21. Prevailing Wages:

Bidder is responsible for complying with all applicable local, State and Federal wage laws, whether or not specifically cited in this bid document.

Per NRS Sections 338.020 through 338.090, certain projects defined as "public works" require the payment of the prevailing wage as determined by the Labor Commissioner. Generally speaking, projects/contracts for construction of a public work valued at less than \$100,000 are exempt from the prevailing wage requirement (NRS 338.080). Bidder shall be fully aware of the prevailing wage requirements of the State of Nevada as detailed in NRS Chapter 338 and price their bid response accordingly. Further information concerning Prevailing Wage rates can be found at:

https://labor.nv.gov/PrevailingWage/Public_Works_Prevailing_Wages/

Federal "Davis Bacon" wages may be applicable if the funding for the project includes Federal funds. These requirements are detailed in the "Special Conditions – Federal Requirements" section that will be included in this bid document when such conditions apply.

Contractor shall compare the applicable wage rate for each classification used on the project and pay the higher of the two rates (Nevada State Prevailing Wage or Davis Bacon Wage) in each case.



22. Apprenticeship Utilization Act:

Bidder acknowledges that the Nevada Legislature has enacted state laws requiring contractors engaged in vertical or horizontal construction who employ workers on one or more public works during a calendar year to use varying levels of apprentices on such public works. *See* NRS 338.01165; SB 82 (2023). Bidder acknowledges that Senate Bill 82 (2023) places compliance and reporting requirements on contractors and subcontractors engaged in public works project, and requires contractors and subcontractors engaged in public works projects to meet annual apprentice use thresholds set by state law, including obligations to provide the Nevada Labor Commissioner with supporting documentation when requested, and an obligation to provide an annual report to the Nevada Labor Commissioner documenting its compliance with Nevada apprenticeship requirements. Bidder acknowledges and certifies that it will comply with NRS 338.01165 and SB 82 (2023), as each may be amended in the future.

23. Conflict of Interest:

No City employee or elected or appointed member of City government, or member of the employee's immediate family, may participate directly or indirectly in the procurement process pertaining to this bid if they:

- (a) Have a financial interest or other personal interest that is incompatible with the proper discharge of their official duties in the public interest or would tend to impair their independence, judgment or action in the performance of their official duties.
- (b) Are negotiating for or have an arrangement concerning prospective employment with bidder. The bidder warrants to the best of his knowledge that the submission of the bid will not create such conflict of interest. In the event such a conflict occurs, the bidder is to report it immediately to the Purchasing Manager. For breach or violation of this warranty, the City shall have the right to annul this contract without liability at its discretion, and bidder may be subject to damages and/or debarment or suspension.

24. Disqualification of Bidder:

Any one or more of the following may be considered as sufficient for the disqualification of a prospective Bidder and the rejection of the Bid:

- (a) The Bidder is not responsive or responsible.
- (b) The quality of services, materials, equipment or labor offered does not conform to the approved plans and specifications.
- (c) There is evidence of collusion among prospective Bidders (Participants in such collusion will receive no recognition as Bidders).

Each bidder shall file a statement executed by, or on behalf of the person, firm, association, or corporation submitting the bid certifying that such person, firm, association, or corporation has not, either directly or indirectly, entered into any agreement, participated in any collusion, or otherwise taken any action, in restraint of free competitive bidding in connection with the submitted bid. Failure to submit the executed statement as part of the bidding documents will make the bid nonresponsive and not eligible for award consideration.

- (d) The Bidder lacks the correct contractor's license classification required for the defined scope of work.
- (e) Lack of competency, understanding of the scope of work, adequate machinery, plant and/or equipment as revealed in routine due diligence associated with bid evaluation.
- (f) Unsatisfactory performance record as shown by past work for the City of Sparks, judged from the standpoint of workmanship, progress, and quality of services/goods provided.
- (g) Uncompleted work which, in the judgment of the City of Sparks, might hinder or prevent the prompt completion of additional work, if awarded.

General Conditions



- (h) Failure to pay or satisfactorily settle all bills due for labor and/or material on any contract(s).
- (i) Failure to comply with any requirements of the City of Sparks.
- (j) Failure to list, as required, all subcontractors who will be employed by the Bidder.
- (k) Any other reason determined, in good faith, to be in the best interest of the City of Sparks.

25. Gratuities:

The City may rescind the right of the bidder to proceed under this agreement if it is found that gratuities in the form of entertainment, gifts, cash or otherwise are offered or given by the bidder, or any agent or representative of the bidder, to any officer or employee of the City with the intent of influencing award of this agreement or securing favorable treatment with respect to performance of this agreement.

26. Bidder's Security (This Section IS IS NOT Applicable to this bid):

A bid deposit in an amount equal to at least 5% of the bid may be required as a bid security by the City. The bid security may only be in cash, a cashier's or certified check made payable to the City of Sparks, or a bid bond. If the bid security is a bond, it shall be executed by a surety insurer authorized to issue surety bonds in the State of Nevada. All Bonding Companies must have an "A" rating or better with Moody's or A.M. Best Company, and be included on the current list of "Companies Holding Certificates of Authority as Acceptable Sureties on Federal Bond and as Acceptable Reinsuring Companies" as published in circular 570 (as amended) by the audit staff, Bureau of Accounts, U.S. Treasury Department. (In other words, the company is T-listed.) The bid security must be executed by the bidder and enclosed with the bid proposal in the sealed bid envelope.

27. Performance and Payment Bonds:

Per NRS 339.025, before any contract, except one subject to the provisions of chapter 408 of NRS, exceeding \$100,000 for any project for the new construction, repair or reconstruction of any public building or other public work or public improvement of any contracting body is awarded to any contractor, he shall furnish to the contracting body the following bonds which become binding upon the award of the contract to the contractor (All Bonding Companies must have an "A" rating or better with Moody's or A.M. Best Company, and be included on the current list of "Companies Holding Certificates of Authority as Acceptable Sureties on Federal Bond and as Acceptable Reinsuring Companies" as published in circular 570 (as amended) by the audit staff, Bureau of Accounts, U.S. Treasury Department. (In other words, the company is T-listed.)):

Performance Bond (This Section IS IS NOT Applicable to this bid):

The Contractor awarded this bid will be required to furnish the City with a surety bond conditioned upon the faithful performance of the contract. This may take the form of a bond executed by a surety company authorized to do business in the State of Nevada and approved by the City of Sparks. The bond shall be in a sum equal to one hundred percent (100%) of the amount of the contract price. Such bond shall be forfeited to the City in the event that bidder receiving the contract shall fail or refuse to fulfill the requirements and all terms and conditions of the contract.

Payment Bond (This Section IS IS NOT Applicable to this bid):

The Contractor awarded this bid will be required to furnish the City with a payment bond. This may take the form of a bond executed by a surety company authorized to do business in the State of Nevada and approved by the City of Sparks. The bond shall be in a sum equal to one hundred percent (100%) of the amount of the contract price. The bond must be solely for the protection of claimants supplying labor or materials to the

General Conditions



contractor to whom the contract was awarded, or to any of his subcontractors, in the prosecution of the work provided for in such contract.

28. Indemnification:

To the fullest extent permitted by law, upon award, Contractor shall hold harmless, indemnify, defend and protect City, its affiliates, officers, agents, employees, volunteers, successors and assigns (“Indemnified Parties”), and each of them from and against any and all claims, demands, causes of action, damages, costs, expenses, actual attorney’s fees, losses or liabilities, in law or in equity, of every kind and nature whatsoever (“Claims”) arising out of or related to any act or omission of Contractor, its employees, agents, representatives, or Subcontractors in any way related to the performance of work under this Agreement by Contractor, or to work performed by others under the direction or supervision of Contractor, including but not limited to:

1. Personal injury, including but not limited to bodily injury, emotional injury, sickness or disease, or death to persons;
2. Damage to property of anyone, including loss of use thereof;
3. Penalties from violation of any law or regulation caused by Contractor’s action or inaction;
4. Failure of Contractor to comply with the Insurance requirements established under this Agreement;
5. Any violation by Contractor of any law or regulation in any way related to the occupational safety and health of employees.

In determining the nature of the claim against City, the incident underlying the claim shall determine the nature of the claim, notwithstanding the form of the allegations against City.

If City’s personnel are involved in defending such actions, Contractor shall reimburse City for the time and costs spent by such personnel at the rate charged City for such services by private professionals.

In cases of professional service agreements, requiring professional liability coverage:

If the insurer by which a Consultant is insured against professional liability does not so defend the City and applicable agents and/or staff, and the Consultant is adjudicated to be liable by a trier of fact, the City shall be entitled to reasonable attorney’s fees and costs to be paid to the City by the Consultant in an amount which is proportionate to the liability of the of the Consultant.

Nothing in this contract shall be interpreted to waive nor does the City, by entering into this contract, waive any of the provisions found in Chapter 41 of the Nevada Revised Statutes.

29. Insurance:

BIDDERS' ATTENTION IS DIRECTED TO THE INSURANCE REQUIREMENTS BELOW. IT IS HIGHLY RECOMMENDED THAT BIDDERS CONFER WITH THEIR RESPECTIVE INSURANCE CARRIERS OR BROKERS TO DETERMINE IN ADVANCE OF BID SUBMISSION THE AVAILABILITY OF INSURANCE CERTIFICATES AND ENDORSEMENTS AS PRESCRIBED AND PROVIDED HEREIN. IF THE APPARENT LOW BIDDER FAILS TO COMPLY STRICTLY WITH THE INSURANCE REQUIREMENTS, THAT BIDDER MAY BE DISQUALIFIED FROM AWARD OF THE CONTRACT.

The City may, unless otherwise required by law, waive or reduce the insurance requirements itemized here, at the discretion of the city’s Contracts and Risk Manager.

General Conditions



Should work be required on City premises or within the public right-of-way, upon award of the contract, the bidder shall provide proof of insurance for the types of coverage, limits of insurance and other terms specified herein, prior to initiation of any services under City, Bid, Proposal or Contract. Coverage shall be from a company authorized to transact business in the State of Nevada and the City of Sparks and shall meet the following minimum specifications:

Contractor shall at its own expense carry and maintain at all times the following insurance coverage and limits of insurance no less than the following or the amount customarily carried by Contractor or any of its subcontractors, whichever is greater. Contractor shall also cause each subcontractor employed by Contractor to purchase and maintain insurance of the type specified herein. All insurers must have AM Best rating not less than A-VII, and be acceptable to the City. Contractor shall furnish copies of certificates of insurance evidencing coverage for itself and for each subcontractor. Failure to maintain the required insurance may result in termination of this contract at City’s option. If Contractor fails to maintain the insurance as set forth herein, City shall have the right, but not the obligation, to purchase said insurance at Contractor’s expense.

Contractor shall provide proof of insurance for the lines of coverage, limits of insurance and other terms specified below prior to initiation of any services. Coverage shall be from a company authorized to transact business in the State of Nevada and the City of Sparks. Contractor and any of its subcontractors shall carry and maintain coverage and limits no less than the following or the amount customarily carried by Contractor or any of its subcontractors, whichever is greater.

Applicable to this Contract	Insurance Type	Minimum Limit	Insurance Certificate	Additional Insured	Waiver of Subrogation
Yes	General Liability/Umbrella (Excess) Liability	\$2,000,000	✓	✓	✓
Yes	Automobile Liability	\$1,000,000	✓	✓	
Yes	Workers’ Compensation	Statutory	✓	N/A	✓
Yes	Employer’s Liability	\$1,000,000	✓	N/A	
No	Professional Liability	\$1,000,000	✓	N/A	N/A
No	Pollution Legal Liability	\$1,000,000	✓	N/A	N/A

Commercial General Liability

Contractor shall carry and maintain Commercial General Liability (CGL) and, if necessary to meet required limits of insurance, commercial umbrella/excess liability insurance with a total limit of not less than the limits specified herein.

For contracts that are for the construction or improvement of public facilities, the Contractor shall obtain and maintain products and completed operations liability coverage through the statute of repose after completion of

General Conditions



the project. Continuing commercial umbrella coverage, if any, shall include liability coverage for damage to the insured's completed work equivalent to that provided under ISO form CG 00 01.

There shall be no endorsement or modification of the CGL limiting the scope of coverage for liability arising from pollution, explosion, collapse, underground property damage, or damage to the named insured's work unless Subcontractor carries and maintains separate policies providing such coverage and provides Contractor evidence of insurance confirming the coverage.

Minimum Limits of Insurance

\$2,000,000 Each Occurrence Limit for bodily injury and property damage

\$2,000,000 General Aggregate Limit

\$2,000,000 Products and Completed Operations Aggregate Limit

\$10,000 Medical Expense Limit

If Commercial General Liability Insurance or other form with a general aggregate limit is used, it shall be revised to apply separately to this PROJECT or LOCATION.

Coverage Form

Coverage shall be at least as broad as the unmodified Insurance Services Office (ISO) Commercial General Liability (CGL) "Occurrence" form CG 00 01 04/13 or substitute form providing equivalent coverage and shall cover liability arising from premises, operations, independent contractors, products-completed operations, personal and advertising injury, and liability assumed under an insured contract (including the tort liability of another assumed in a business contract).

Additional Insured

City, its officers, agents, employees, and volunteers are to be included as insureds using the applicable ISO additional insured endorsement(s) or substitute forms providing equivalent coverage, in respects to damages and defense arising from: activities performed by or on behalf of Contractor, including the insured's general supervision of Contractor; products and completed operations of Contractor; premises owned, occupied, or used by Contractor. The coverage shall contain no special limitations on the scope of protection afforded to City, its officers, employees, or volunteers. Additional insured status for City shall apply until the expiration of time within which a claimant can bring suit per applicable state law.

Primary and Non-Contributory

Contractor's insurance coverage shall apply as primary insurance with respect to any other insurance or self-insurance programs afforded to City, Nevada Department of Transportation (NDOT), their officers, agents, employees, and volunteers. There shall be no endorsement or modification of the CGL to make it excess over other available insurance; alternatively, if the CGL states that it is excess or pro rata, the policy shall be endorsed to be primary with respect to the additional insured. Any insurance or self-insurance maintained by City, its officers, employees, or volunteers shall be excess of Contractor's insurance and shall not contribute with it in any way.

Waiver of Subrogation

Contractor waives all rights against City and its agents, officers, directors and employees for recovery of damages to the extent these damages are covered by the commercial general liability or commercial umbrella liability insurance maintained pursuant to this agreement. Insurer shall endorse CGL policy as required to waive subrogation against the City with respect to any loss paid under the policy.



Endorsements

Policy forms or endorsements are required confirming coverage for all required additional insureds. The forms or endorsements for CGL shall be at least as broad as the unmodified ISO additional insured endorsement CGO 20 10 07/04 and CG 20 37 07/04 or substitute forms providing additional insured coverage for products and completed operations.

A waiver of subrogation in favor of City shall be endorsed to the policy using an unmodified Waiver of Transfer of Rights of Recovery of Others to Us ISO CG 24 04 05 09, or a substitute form providing equivalent coverage.

Electronic Data Liability

If any underground work will be performed, Contractor shall maintain electronic data liability insurance applicable to the Project and insuring against liability arising out of the loss of, loss of use of, damage to, corruption of, inability to access, or inability to manipulate electronic data. This coverage shall be maintained with a limit of liability of not less than \$1,000,000 and provide coverage at least as broad as electronic data liability coverage form CG 04 37 (or substitute form providing equivalent coverage).

Railroad Protective Liability

For any construction or demolition work within fifty (50) feet of a railroad, Contractor shall maintain Railroad Protective Liability insurance on behalf of and in the name of the railroad, as named insured, with a limit of \$6,000,000 per occurrence or higher limit if required by the railroad. Contractor shall also ensure that any exclusions pertaining to the indemnification of a railroad are removed from its CGL policy or that ISO form CG 24 17 (Contractual Liability-Railroads Endorsements) is included in the coverage.

Business Automobile Liability

Minimum Limits of Insurance

\$1,000,000 Combined Single Limit per accident for bodily injury and property damage or the limit customarily carried by Contractor, whichever is greater. No aggregate limit may apply. Coverage may be combined with Excess/Umbrella Liability coverage to meet the required limit.

Coverage Form

Coverage shall be at least as broad as the unmodified Insurance Services Office (ISO) Business Automobile Coverage form CA 00 01 10/13, CA 00 25 10/13, CA 00 20 10/13 or substitute form providing equivalent coverage. Such insurance shall cover liability arising out of any auto (including owned, hired, and non-owned autos).

Pollution liability coverage at least as broad as that provided under the ISO pollution liability—broadened coverage for covered autos endorsement (CA 99 48) shall be provided, and the Motor Carrier Act endorsement (MCS 90) shall be attached for all contracts involving transportation of “hazardous material” as this term is defined by applicable law, including, but not limited to, waste, asbestos, fungi, bacteria and mold.

Additional Insured

City, its officers, agents, employees, and volunteers are to be included as insureds with respect to damages and defense arising from the ownership, maintenance or use of automobiles owned, leased, hired, or borrowed by the Contractor. The coverage shall contain no special limitations on the scope of protection afforded to City, its officers, employees, or volunteers. Additional insured status for City shall apply until the expiration of time within which a claimant can bring suit per applicable state law.

General Conditions



Endorsements

A policy endorsement is required listing all required additional insureds. The endorsement for Business Automobile Liability shall be at least as broad as the unmodified ISO CA 20 48 10/13 or a substitute form confirming City's insured status for Liability Coverage under the Who Is An Insured Provision contained in Section II of the coverage form ISO CA 00 01 10/13.

Waiver of Subrogation.

Contractor waives all rights against City, its officers, agents, employees, and volunteers for recovery of damages to the extent these damages are covered by the commercial general liability or commercial umbrella liability insurance maintained pursuant to this agreement. Contractor's insurer shall endorse policy to waive subrogation against City with respect to any loss paid under the policy.

Workers' Compensation and Employer's Liability

Contractor shall carry and maintain workers' compensation and employer's liability insurance meeting the statutory requirements of the State of Nevada, including but not limited to NRS 616B.627 and NRS 617.210 or provide proof that compliance with the provisions of Nevada Revised Statutes Chapters 616A-D and all other related chapters is not required. It is understood and agreed that there shall be no coverage provided for Contractor or any Subcontractor of the Contractor by the City. Contractor agrees, as a precondition to the performance of any work under this Agreement and as a precondition to any obligation of the City to make any payment under this Agreement to provide City with a certificate issued by an insurer in accordance with NRS 616B.627 and with a certificate of an insurer showing coverage pursuant to NRS 617.210.

It is further understood and agreed by and between City and Contractor that Contractor shall procure, pay for and maintain the above-mentioned coverage at Contractor's sole cost and expense.

Should Contractor be self-funded for workers' compensation and employer's liability insurance, Contractor shall so notify City in writing prior to the signing of this Contract. City reserves the right to approve said retentions, and may request additional documentation, financial or otherwise, for review prior to the signing of this Contract.

Upon completion of the project, Contractor shall, if requested by City, provide a Final Certificate for itself and each Subcontractor showing that Contractor and each Subcontractor had maintained the required Workers Compensation and Employer's Liability by paying all premiums due throughout the entire course of the project.

Nevada law allows the following to reject workers' compensation coverage if they do not use employees or subcontractors in the performance of work under the contract:

- Sole proprietors (NRS 616B.627 and NRS 617.210)
- Unpaid officers of quasi-public, private or nonprofit corporations (NRS 616B.624 and NRS 617.207)
- Unpaid managers of limited liability companies (NRS 616B.624 and NRS 617.207)
- An officer or manager of a corporation or limited liability company who owns the corporation or company (NRS 616B.624 and NRS 617.207)

If a contractor has rejected workers' compensation coverage under applicable Nevada law, the contractor must indicate the basis for the rejection of coverage and complete, sign and have notarized an Affidavit of Rejection of Coverage. The Affidavit must be completed, signed and notarized prior to performance of any work.

General Conditions



Minimum Limits of Insurance

Workers' Compensation:	Statutory Limits
Employer's Liability:	\$1,000,000 Bodily Injury by Accident – Each Accident
	\$1,000,000 Bodily Injury by Disease – Each Employee
	\$1,000,000 Bodily Injury by Disease – Policy Limit

Coverage Form

Coverage shall be at least as broad as the unmodified National Council on Compensation Insurance (NCCI) Workers Compensation and Employer's Liability coverage form WC 00 00 07/11 or substitute form providing equivalent coverage.

OTHER INSURANCE COVERAGES (IF APPLICABLE)

Professional Liability Insurance (if Applicable) \$1,000,000 each claim limits of liability or whatever limit is customarily carried by the Contractor, whichever is greater, for design, design-build or any type of professional services. If coverage is required on a claims-made or claims-made and reported basis, any applicable retroactive or pending & prior litigation dates must precede the effective date of this contract. Continuous coverage shall be maintained, or an extended reporting period shall be obtained for a period of at least three (3) years following completion of the project.

Contractors Pollution Liability Insurance (If Applicable)- \$1,000,000 per occurrence and \$2,000,000 aggregate or whatever amount is acceptable to the City for any exposure to "hazardous materials" as this term is defined in applicable law, including but not limited to waste, asbestos, fungi, bacterial or mold.

Coverage shall apply to bodily injury; property damage, including loss of use of damaged property or of property that has not been physically injured; cleanup costs; and defense, including costs and expenses incurred in the investigation, defense, or settlement of claims.

City shall be included as an insured under Contractor's pollution liability insurance.

If coverage is required on a claims-made or claims-made and reported basis, any applicable retroactive or pending & prior litigation dates must precede the effective date of this contract. Continuous coverage shall be maintained, or an extended reporting period shall be obtained for a period of at least three (3) years following completion of the project.

If the scope of services as defined in this contract includes the disposal of any hazardous materials from the job site, Contractor must furnish to City evidence of pollution liability insurance maintained by the disposal site operator for losses arising from the insured facility accepting waste under this contract. Coverage certified to the City under this section must be maintained in minimum amounts of \$1,000,000 per loss, with an annual aggregate of at least \$2,000,000.

Lower tier sub-subcontractors, Truckers, Suppliers: Evidence confirming lower tier subcontractors, truckers and suppliers are maintaining valid insurance prior to beginning work on the project to meet the requirements set forth herein on Subcontractor, including but not limited to all additional insured requirements of Subcontractor.

ALL COVERAGES

General Conditions



Coverage shall not be suspended, voided, canceled, or non-renewed by either CONTRACTOR or by the insurer, reduced in coverage or in limits except after thirty (30) days' prior written notice has been given to CITY except for ten (10) days' notice for nonpayment of premium.

DEDUCTIBLES AND RETENTIONS

Any deductibles or self-insured retentions that exceed \$100,000.00 per occurrence or claim must be declared to and approved by the City's Contracts and Risk Manager and prior to signing this Contract. City is entitled to request and receive additional documentation, financial or otherwise, prior to giving its approval of the deductibles and self-insured retentions. Any changes to the deductibles or self-insured retentions made during the term of this Contract or during the term of any policy must be approved by City's Contracts and Purchasing Manager prior to the change taking effect. Contractor is responsible for any losses within deductibles or self-insured retentions.

OTHER INSURANCE PROVISIONS

Should City and Contractor agree that higher coverage limits are needed warranting a project policy, project coverage shall be purchased and the premium for limits exceeding the above amount may be borne by City. City retains the option to purchase project insurance through Contractor's insurer or its own source.

Any failure to comply with reporting provisions of the policies shall not affect coverage provided to City, its officers, agents, employees, or volunteers.

ACCEPTABILITY OF INSURERS

Insurance is to be placed with insurers with a Best's rating of no less than A-VII and acceptable to the City. City, with the approval of the Risk Manager, may accept coverage with carriers having lower Best's ratings upon review of financial information concerning Contractor and insurance carrier. City reserves the right to require that Contractor's insurer be a licensed and admitted insurer in the State of Nevada, or meet any applicable state and federal laws and regulations for non-admitted insurance placement.

VERIFICATION OF COVERAGE

Contractor shall furnish City with certificates of insurance and with original endorsements affecting coverage required by this contract. The certificates and endorsements for each insurance policy are to be signed by a person authorized by that insurer to bind coverage on its behalf.

Prior to the start of any Work, Contractor must provide the following documents to City of Sparks, Attention: Purchasing Division, P.O. Box 857, Sparks, NV 89432-0857:

- A. Certificate of Insurance.** Contractor must provide a Certificate of Insurance form to the City of Sparks to evidence the insurance policies and coverage required of Contractor.
- B. Additional Insured Endorsements.** An original Additional Insured Endorsement, signed by an authorized insurance company representative, must be submitted to the City of Sparks, by attachment to the Certificate of Insurance, to evidence the endorsement of the City of Sparks as additional insured.
- C. Policy Cancellation Endorsement.** Except for ten (10) days' notice for non-payment of premium, each insurance policy shall be endorsed to specify that without thirty (30) days prior written notice to the City of Sparks, the policy shall not be suspended, voided, cancelled or non-renewed, and shall provide that notices required by this paragraph shall be sent by certified mailed to the address specified

General Conditions



above. A copy of this signed endorsement must be attached to the Certificate of Insurance. If endorsements are not available, Contractor shall be responsible to provide prior written notice to City as soon as practicable upon receipt of any notice of cancellation, non-renewal, reduction in required limits or other material change in the insurance required under this Agreement.

D. Bonds (as Applicable). Bonds as required and/or defined in the original bid documents.

All certificates and endorsements are to be addressed to the City of Sparks, Purchasing Division and be received and approved by City before work commences. The City reserves the right to require complete certified copies of all required insurance policies at any time.

SUBCONTRACTORS

Contractor shall include all Subcontractors as insureds under its policies or shall furnish separate certificates and endorsements for each Subcontractor. All coverages for Subcontractors shall be subject to all the requirements stated herein.

MISCELLANEOUS CONDITIONS

1. Contractor shall be responsible for and remedy all damage or loss to any property, including property of City, caused in whole or in part by Contractor, any Subcontractor, or anyone employed, directed, or supervised by Contractor.
2. Nothing herein contained shall be construed as limiting in any way the extent to which Contractor may be held responsible for payment of damages to persons or property resulting from its operations or the operations of any Subcontractors under it, and such coverage and limits required herein shall not be deemed as a limitation on Contractor's liability under the indemnities granted to City in this contract.
3. In addition to any other remedies City may have if Contractor fails to provide or maintain any insurance policies or policy endorsements to the extent and within the time herein required, City may, at its sole option:
 - a. Purchase such insurance to cover any risk for which City may be liable through the operations of Contractor under this Agreement and deduct or retain the amount of the premiums for such insurance from any sums due under the Agreement;
 - b. Order Contractor to stop work under this Agreement and/or withhold any payments which become due Contractor here under until Contractor demonstrates compliance with the requirements hereof; or,
 - c. Terminate the Agreement.
4. If Contractor's liability policies do not contain the standard ISO separation of insureds condition, or a substantially similar clause, they shall be endorsed to provide cross-liability coverage.

30. Safety Program:

Upon award, the Contractor shall be responsible for initiating, maintaining, and supervising all safety precautions and programs in connection with the work. The Contractor shall take all necessary precautions for the safety of, and shall provide all necessary protection to prevent damage, injury, or loss to:

1. All employees on the work site and all other persons who may be affected thereby.
2. All the work, materials, and equipment to be incorporated therein, whether in storage on or off the site.

General Conditions



3. Other property at the site or adjacent thereto, including trees, shrubs, lawns, walks, pavements, roadways, structures, and utilities not designated for removal, relocation, or replacement in the course of construction.

Contractor shall comply with all applicable laws, ordinances, rules, regulations, and others of any public authority having jurisdiction for the safety of persons or property or to protect them from damage, injury, or loss. He shall erect and maintain, as required by existing conditions and progress on the work, all necessary safeguards for safety and protection, including posting danger signs, other warnings against hazards, promulgating safety regulations, and notifying owners and users of adjacent utilities. Contractor shall comply with OSHA'S Hazard Communication Standards.

Contractor shall designate a responsible member of its organization at the site whose duty shall be the prevention of accidents. This person shall be Contractor's superintendent unless otherwise designated in writing by Contractor to the Owner and the Engineer.

31. Award of Contract:

- (a) Bids/Proposals will be analyzed and award will be made to the lowest, responsive and responsible bidder whose bid conforms to the solicitation and whose bid is considered to be most advantageous to the City, price and other factors considered. Factors to be considered may include, but are not limited to: bidder's past performance, total unit cost, economic cost analysis, life cycle costs, warranty and quality, maintenance cost, durability, the operational requirements of the City and any other factors which will result in the optimum economic benefit to the City.
- (b) The City reserves the right to reject any item or items, to waive informalities, technical defects and minor irregularities in bids/proposals received; and to select the bid(s) or proposal(s) deemed most advantageous to the City. Should the City elect to waive a right it will not constitute an automatic waiver of that right in the future nor will it impact any other right or remedy. The City may consider bids/proposals submitted on an "all or nothing" basis if the bid/proposal is clearly designated as such.
- (c) The City reserves the right to award one or more contracts on the bids/proposals submitted, either by award of all items to one bidder or by award of separate items or groups of items to various bidders as the interests of the City may require, unless the bidder clearly specifies otherwise in his bid.
- (d) Upon acceptance by the City of Sparks, the solicitation, bid, proposal, or price quotation and issuance of a purchase order issued to the successful bidder shall be deemed to result in a binding contract incorporating those terms and these General Conditions without further action required by either party. Items are to be furnished as described in the bid and in strict conformity with all instructions, conditions, specifications, and provisions in the complete contract, as defined by this clause or any related integrated agreement.

32. Request for Proposal (RFP) Submittals:

In the case of Request for Proposals (RFP's), it should be noted that the documents submitted by prospective bidders are competitive sealed proposals and not competitive sealed bids. When proposals are opened, prices and other information will not be made public until the proposal is awarded. There shall be no disclosure of any bidder's information to competing bidders prior to the award of the proposal.

By their nature, proposals will include a number of variables that will vary based on the complexity of the product or service addressed within the proposal. Therefore, the evaluation of RFP's and the recommendation for award will not be based on price alone. Selection criteria will be better defined for each scope of work in the Special Conditions section of this bid.

General Conditions



Upon award of the contract, the executed contract and proposals will become public information. Accordingly, each proposal should be submitted on the vendor's most favorable terms from a price and technical standpoint.

33. Bidder Preference Law (This Section IS IS NOT Applicable to this bid):

This project will be bid and awarded under the Provisions(s) of NRS 338.147, which restricts preference given to certain contractors on Public Works Projects. The NRS cited in this section is meant to be a reference only. Each bidder shall acquaint himself with the latest provisions of NRS 338.147.

If the Contract for any Public Works Construction Project is expected to cost \$250,000 or more, then all Contractors wishing to receive benefit of their preference status in the evaluation of bids must submit a copy of their Certificate of Bidder Preference issued by the State Contractor's Board. (Call 775-688-1141 or 775-486-1100 to obtain certification information from the State Contractors Board). Contractors who do not submit a preference certificate at the time of their bid are presumed to have wished not to exercise the benefit of their preference, or do not possess the certificate of eligibility.

To the extent Contractor has sought, qualified and receives a bidding preference on this project, pursuant to Nevada Revised Statutes Chapter 338, Contractor acknowledges and agrees that the following requirements will be adhered to, documented and attained for the duration of the Project:

1. At least 50 percent of the workers employed on the Project (including subcontractors) hold a valid driver's license or identification card issued by the Nevada Department of Motor Vehicles;
2. All vehicles used primarily for the public work will be (a) registered and (where applicable) partially apportioned to Nevada; or (b) registered in Nevada; and
3. The Contractor shall maintain and make available for inspection within Nevada all payroll records related to the Project.

Contractor recognizes and accepts that failure to comply with any requirements herein shall be a material breach of the contract and entitle the City of Sparks to liquidated damages in the amount set by statute. In addition, the Contractor recognizes and accepts that failure to comply with any requirements herein may lose its certification for a preference in bidding and/or its ability to bid on any contracts for public works pursuant to NRS Chapter 338.

To the extent Contractor has sought, qualified and receives a bidding preference, and this project has a value of over \$250,000 pursuant to Nevada Revised Statutes Chapter 338, each contract between the contractor, applicant or design-build team and a subcontractor must provide for the apportionment of liquidated damages assessed pursuant to this section if a person other than the Contractor was responsible for the breach of a contract for a public work caused by a failure to comply with a requirement of Items 1-3 within this section. The apportionment of liquidated damages must be in proportion to the responsibility of each party for the breach.

This section shall not be applicable for projects in which some or all of the funding comes from Federal sources.

34. Tie Bids:

General Conditions



Should identical low, responsive and responsible bids be received from two bidders, the City of Sparks Purchasing Manager shall notify all parties involved in the tie and may at his option utilize a coin-flip to determine the low bidder who shall be recommended for award. Or;

Should there be three or more low, responsive and responsible tie bids the Purchasing Manager shall exercise the following tie breaking method, unless another alternative is apparent and prudent: The City of Sparks Purchasing Manager shall set a mutually agreed upon time where, in his office, he shall shuffle a new deck of playing cards and have each bidder's representative cut the cards. The tie bidder who cuts the highest card (with Ace high) shall be recommended for bid award.

35. Appeals/Protests – Bids Only (Not Applicable to Request for Proposals):

A person who submits a bid on a contract may, after the bids are opened and within 5 business days after the date the "Recommendation to Award" is issued by the City, unless otherwise stated in the Special Conditions, file a notice of protest regarding the awarding of the contract. The City's "Recommendation to Award" will be dated and posted on the City's public website within the area where bid notices and bid re-caps are posted (Currently: <http://www.cityofsparks.us/bids>).

- (a) A notice of protest must include a written statement setting forth with specificity the reasons the person filing the notice believes the applicable provisions of law were violated.
- (b) A person filing a notice of protest may be required by the governing body or its authorized representative, at the time the notice of protest is filed, to post a bond with a good and solvent surety authorized to do business in this State or submit other security, in a form approved by the governing body or its authorized representative, to the governing body or its authorized representative who shall hold the bond or other security until a determination is made on the protest. A bond posted or other security submitted with a notice of protest must be in an amount equal to the lesser of:
 - (1) Twenty-five percent of the total value of the bid submitted by the person filing the notice of protest;
 - or
 - (2) Two hundred fifty thousand dollars (\$250,000).
- (c) A notice of protest filed in accordance with the provisions of this section operates as a stay of action in relation to the awarding of any contract until a determination is made by the governing body or its authorized representative on the protest.
- (d) A person who submits an unsuccessful bid may not seek any type of judicial intervention until the governing body or its authorized representative has made a determination on the protest and awarded the contract.
- (e) A governing body or its authorized representative is not liable for any costs, expenses, attorney's fees, loss of income or other damages sustained by a person who submits a bid, whether or not the person files a notice of protest pursuant to this section.
- (f) If the protest is upheld, the bond posted or other security submitted with the notice of protest must be returned to the person who posted the bond or submitted the security. If the protest is rejected, a claim may be made against the bond or other security by the governing body or its authorized representative in an amount equal to the expenses incurred by the governing body or its authorized representative because of the unsuccessful protest. Any money remaining after the claim has been satisfied must be returned to the person who posted the bond or submitted the security.

36. Documentation:

Due to the time constraints that affect contract performance, all required documents, certificates of insurance and bonds shall be provided to the City within ten (10) calendar days following award or date of request by

General Conditions



City, whichever is later. Any failure to comply may result in bid being declared non-responsive and rejected, and at City's option, the bid bond may be attached for damages suffered.

37. Discounts:

- (a) Prompt payment discounts will not be considered in evaluating bids for award. However, offered discounts will be taken if payment is made within the discount period, even though not considered in the evaluation of bids.
- (b) In connection with any discount offered, time will be computed from date of delivery and acceptance, or invoice receipt, whichever is later. Payment is deemed to be made for the purpose of earning the discount on the date of mailing of the City check.
- (c) Any discount offered other than for prompt payment should be included in the net price quoted and not included in separate terms. In the event this is not done, the City reserves the right to accept the discount offered and adjust prices accordingly on the Purchase Order.

38. Seller's Invoice:

Invoices shall be prepared and submitted in duplicate to the address shown on the Purchase Order. Separate invoices are required for each Purchase Order. Invoices shall contain the following information: Purchase Order number, item number, description of supplies or services, sizes, unit of measure, quantity, unit price and extended totals.

39. Inspection and Acceptance:

Inspection and acceptance will be at destination unless specified otherwise, and will be made by the City department shown in the shipping address or other duly authorized representative of the City. Until delivery and acceptance, and after any rejection, risk of loss will be on the bidder unless loss results from negligence of the City.

40. Lost and Damaged Shipments:

Risk of loss or damage to items prior to the time of their receipt and acceptance by the City is upon the bidder. The City has no obligation to accept damaged shipments and reserves the right to return at the bidder's expense damaged merchandise even though the damage was not apparent or discovered until after receipt of the items.

41. Late Shipments:

Bidder is responsible to notify the City department receiving the items and the Purchasing Manager of any late or delayed shipments. The City reserves the right to cancel all or any part of an order if the shipment is not made as promised.

42. Document Ownership:

All technical documents and records originated or prepared pursuant to this contract, including papers, reports, charts, and computer programs, shall be delivered to and become the exclusive property of the City and may be copyrighted by the City. Bidder assigns all copyrights to City by undertaking this agreement.

43. Advertisements, Product Endorsements:

City employees and agencies or organizations funded by the City of Sparks are prohibited from making endorsements, either implied or direct, of commercial products or services without written approval of the City Manager. No bidder may represent that the City of Sparks has endorsed their product or service without prior written approval.



44. Vendor Workplace Policies

No Vendor providing a service, program or activity to the public on behalf of the City shall discriminate against any person because of sex, race, color, creed, national origin or disability. Vendor, if providing a service, program or activity to the public on behalf of the City, shall comply with the Americans with Disability Act and City's policies pursuant thereto when providing said service, program or activity.

The City of Sparks is an Affirmative Action/Equal Opportunity Employer. Bidders shall be cognizant of the requirements for compliance with Executive Order 11246, entitled "Equal Employment Opportunity" as amended by Executive Order 11375 and as supplemented in regulations of the U.S. Department of Labor (41 CFR part 60).

The City of Sparks hereby notifies all bidders that it will affirmatively ensure that in any contract entered into pursuant to this advertisement, minority business enterprises will be afforded full opportunity to submit bids in response to this invitation and will not be discriminated against on the grounds of race, color, or national origin in consideration for an award.

The City of Sparks hereby notifies all bidders that it will not discriminate in the award of this contract on the basis of race, color, national origin, religion, sex or handicap.

The City of Sparks will on its own initiative, take affirmative action, including the imposition of contract sanctions and the initiation of appropriate legal proceedings under any applicable State or Federal law to achieve equal employment opportunity on all Projects and will actively cooperate with the Federal Highway Administration in all investigations and enforcement actions undertaken by the Federal Highway Administration. In conjunction with the above statement, the City of Sparks will not issue plans to an irresponsible bidder. Subsection (B) of Section 112 of Title 23 United States Code has been amended by adding at the end thereof, the following: "Contracts for the construction of each project shall be awarded only on the basis of the lowest responsive bid submitted by a bidder meeting established criteria of responsibility."

The City of Sparks will, in addition to the other Equal Employment Opportunity provisions which are enumerated elsewhere in the Contract Documents, require an affirmative action program from each Contractor who holds an individual contract or subcontract, in excess of \$10,000.00, in accordance with the requirements in FHWA Form 1273.

The following requirements apply to the person, firm, association or corporation in order for the bid to be considered.

**NOTICE OF REQUIREMENT FOR AFFIRMATIVE
ACTION TO ENSURE EQUAL EMPLOYMENT
OPPORTUNITY (EXECUTIVE ORDER 11246)**

The Offeror's or Bidder's attention is called to the "Equal Opportunity Clause" and the "Standard Federal Equal Employment Opportunity Construction Contract Specifications" set forth herein.

The following goal for female utilization shall be included in all Federal and Federally assisted construction contracts and subcontracts in excess of \$10,000. The goal is applicable to the Contractor's aggregate on-site construction work force whether or not part of that work force is performing work on a Federal or Federally assisted construction contract or subcontract.

General Conditions



FEMALE PARTICIPATION STATEWIDE

Time Period	Goal
Until further notice.....	6.9%

Until further notice, the following goals for minority utilization in each construction craft and trade shall be included in all Federal or Federally assisted construction contracts and subcontracts in excess of \$10,000 to be performed in the respective geographical areas. The goals are applicable to each non-exempt Contractor's total on-site construction work force, regardless of whether or not part of that work force is performing work on a Federal, Federally assisted or non-Federally related project, contract or subcontract.

Construction Contractors which are participating in an approved Hometown Plan (see 41 CFR 60-4.5) are required to comply with the goals of the Hometown Plan with regard to construction work they perform in the area covered by the Hometown Plan. With regard to all their other covered construction work, such Contractors are required to comply with the applicable Standard Metropolitan Statistical Area (SMSA) or Economic Area (EA) goal contained herein.

NEVADA ECONOMIC AREA

SMSA Counties, NV Clark.....	13.9%
163 Las Vegas, NV	
4120 Las Vegas, NV	
Non-SMSA Counties, NV Esmeralda, NV Lincoln, NV Nye.....	12.6%
SMSA Counties, NV Washoe	8.2%
164 Reno, NV	
6720 Reno, NV	
Non-SMSA Counties, NV Churchill, NV Douglas,	9.2%
NV Elko, NV Eureka, NV Humboldt, NV Lander,	
NV Lyon, NV Mineral, NV Pershing, NV Storey,	
NV White Pine, NV Carson City	

These goals are applicable to all the Contractor's construction work (whether or not it is Federal or Federally assisted) performed in the covered area. If the Contractor performs construction work in a geographical area located outside of the covered area, it shall apply the goals established for such geographical area where the work is actually performed. With regard to this second area, the Contractor also is subject to the goal for both its Federally involved and non- Federally involved construction.

The Contractor's compliance with the Executive Order and the regulation in 41 CFR Part 60-4 shall be based on its implementation of the Equal Opportunity Clause, specific affirmative action obligations required by the specifications set forth in 41 CFR 60-4.3(a), and its efforts to meet the goals. The hours of minority and female employment and training must be substantially uniform throughout the length of the contract, and in each trade, and the Contractor shall make a good faith effort to employ minorities and women evenly on each of its projects. The transfer of minority or female employees or trainees from contractor to contractor or from project to project for the sole purpose of meeting the Contractor's goals shall be a violation of the contract, the Executive Order and the regulations in 41 CFR Part 60-4. Compliance with the goals will be measured against the total work hours performed.

General Conditions



The Contractor shall provide written notification to the City of Sparks and the Director of the Office of Federal Contract Compliance Programs within 10 working days of award of any construction subcontract in excess of \$10,000 at any tier for construction work under the contract resulting from this solicitation. The notification shall list the name, address and telephone number of the subcontractor; employer identification number of the subcontractor; estimated dollar amount of the subcontract; estimated starting and completion dates of the subcontract; and the geographical area in which the subcontract is to be performed.

45. Business License Requirement:

All companies doing business with, or within, the City of Sparks are required to obtain and maintain a current business license from the City of Sparks prior to the commencement of work per Sparks Municipal Code Section 5.08.020A. Bidder(s) awarded a contract resulting from this bid shall be required to obtain a current business license if they do not already possess one.

46. City Provisions to Prevail:

Except as indicated in the specifications, the City's standard General Conditions shall govern any contract award. Any standard terms and conditions of bidder submitted by bidder shall not be acceptable to City unless expressly agreed to by the City. The City reserves the right to reject bidder's bid as non-responsive, to consider the bid without bidder's standard terms and conditions, or to require bidder to delete reference to such, as a condition of evaluation or award of the bid. If, after award of contract, bidder (contract vendor) provides materials or services accompanied by new or additional standard terms or conditions, they too shall be considered void and City may require deletion as a further condition of performance by vendor.

47. Invalid Provisions:

In the event that any one or more of the provisions of this agreement shall be found to be invalid, illegal or unenforceable, the remaining provisions shall remain in effect and be enforceable.

48. Amendments and Modifications:

The Purchasing Manager may at any time, by written order, and without notice to the sureties, make a modification to the contract or an amendment to the Purchase Order, within the general scope of this contract, in (1) quantity of materials or service, whether more or less; (2) drawings, designs, or specifications, where the supplies to be furnished are to be specially manufactured for the City; (3) method of shipment or packing; and (4) place of delivery. If any such change causes an increase or decrease in the cost or the time required for the performance of this contract, an equitable adjustment shall be made by written modification of the contract or amendment to the Purchase Order. Any claim by the bidder for adjustment under this clause must be asserted within 30 calendar days from the notification date.

49. Assignment:

Vendor shall not assign or delegate duties or responsibilities under this agreement, in whole or in part, without prior written approval of the City.

50. Disputes After Award:

Except as otherwise provided in these provisions, any dispute concerning a question of fact arising under this contract which is not disposed of by agreement shall be decided by the Purchasing Manager, who shall reduce this decision to writing and mail a copy to the bidder. The decision of the Purchasing Manager shall be final and conclusive, unless bidder requests arbitration within ten (10) calendar days. Pending final decision of a dispute, the bidder shall proceed diligently with the performance of the contract and in accordance with the Purchasing Manager's decision.

General Conditions



51. Arbitration after Award:

Any and all disputes, controversies or claims arising under or in connection with the contract resulting from this bid, including without limitation, fraud in the inducement of this Contract, or the general validity or enforceability of this Contract, shall be governed by the laws of the State of Nevada without giving effect to conflicts of law principles, may be submitted to binding arbitration before one arbitrator, and shall be conducted in accordance with the Commercial Arbitration Rules of the American Arbitration Association in a private manner in Washoe County, Nevada. This award shall be final and judgment may be entered upon it in any court having jurisdiction thereof. In reaching this final award, the arbitrator shall have no authority to change or modify any provision of this Contract. All other expenses of arbitration shall be borne equally by the parties. All fees, including legal fees, shall be borne by the party who incurred them. All costs of enforcement shall be borne by the losing party. Each party shall have the right to discovery in accordance with the Nevada Rules of Civil Procedure.

52. Lawful Performance:

Vendor shall abide by all Federal, State and Local Laws, Ordinances, Regulations, and Statutes as may be related to the performance of duties under this agreement. In addition, all applicable permits and licenses required shall be obtained by the vendor, at vendor's sole expense.

53. Annual Appropriation of Funds:

Multi-year term supply and service contracts and leases are subject to annual appropriation of funds by the City Council. The City plans and makes appropriations to the City Budget with respect to a fiscal year that starts July 1st and ends June 30th of each year. Payments made under term contracts and leases are considered items of current expense. Purchase Orders are funded when issued; therefore, they are current expense items and are not subject to any subsequent appropriation of funds.

Continuance of a multi-year contract beyond the limits of funds available shall be contingent upon appropriation of the requisite funds in the ensuing fiscal year and the termination of this contract due to lack of appropriation shall be without penalty.

54. Extension:

When in the City's best interest, this agreement may be extended on a daily, month-to-month, or annual basis by mutual agreement of both parties. Services and/or materials received under an extension shall be in accordance with pricing, terms, and conditions, as described herein.

55. Termination:

The City may terminate this agreement and be relieved of any consideration to the vendor should vendor fail to perform in the manner required. Furthermore, the City may terminate this agreement for any reason without penalty upon giving thirty (30) days written notice to the vendor. In the event of termination, the full extent of City liability shall be limited to an equitable adjustment and payment for materials and/or services authorized by and received to the satisfaction of the City prior to termination.

56. Venue:

This agreement shall be governed by and interpreted according to the laws of the State of Nevada, and venue for any proceeding shall be in Washoe County.

Special Conditions and Specifications (Specific to Project)

In instances where the Special Conditions conflict with the General Conditions, the Special Conditions will prevail with respect to that instance or item(s).

SPECIAL PROVISIONS
2024 CITY OF SPARKS PEDESTRIAN RAMP REPLACEMENT PROJECT-
FEDERALLY FUNDED
BID #24/25-001, PWP# WA-2025-008
FEDERAL PROJECT #SI-0032-(381)
NDOT PROJECT #61185

These Special Provisions supplement and modify the Standard Specifications for Public Works Construction, 2012 version as adopted by the City of Sparks, Nevada. All of the requirements and provisions of said Standard Specifications shall apply except where modified by the plans and these Special Provisions.

SECTION 1: SCOPE OF WORK

Workscope: The work includes but is not limited to, removal and replacement of curb, gutter sidewalk, and ADA ramps and other miscellaneous associated work activities necessary to complete the project as stated in the plans and bid specifications. The location of the work is within the City limits of the City of Sparks, Washoe County, Nevada. For use in determining proper prevailing wage rates, the project varies from approximately 4.9 miles to 11.8 miles from the City of Reno Court House.

SECTION 2: SPECIAL PROVISIONS

The requirements set forth in these “Special Provisions” shall be used in addition to those set forth in “Standard Specifications for Public Works Construction”.

SECTION 3: STANDARD SPECIFICATIONS

All materials furnished and work performed shall be done in accordance with the 2012 version of the “Standard Specifications for Public Works Construction” (Orange Book) and any revisions thereto if not covered or amended by the Special Provisions. The “Standard Specifications for Public Works Construction” are herein referred to as “Standard Specifications”.

SECTION 4: STANDARD DETAILS

All materials furnished and work performed shall be done in accordance with the most current edition of the City of Sparks “Standard Details” located on the City’s website. For any work not specifically covered by the City’s ‘Standard Details’, the contractor shall refer to the “Standard Details for Public Works Construction” (Orange Book), and any revisions thereto if not covered or amended by the Special Provisions.

SECTION 5: NOTICE TO PROCEED AND TIME SCHEDULE

An official "Notice to Proceed" specifying the date by which construction operations shall be started will be issued in writing and delivered to the CONTRACTOR by the City at the Pre-construction Meeting. Contract time will begin on the date specified in the "Notice to Proceed", unless operations begin at an earlier date, in which case the date that such operations begin will apply. The CONTRACTOR shall immediately begin and diligently prosecute the work to completion. The CONTRACTOR shall obligate himself to complete the work within the stated time limits. All work described in this document shall be completed within **thirty (30) working days** from the time of issuance of the Notice to Proceed.

SECTION 6: LIQUIDATED DAMAGES

In case all work called for under the contract is not completed before or upon the expiration of the time limits set forth above, it is agreed by the parties to the contract that damage will be sustained by the City and that it will be impracticable to determine accurately the actual damage the City will sustain in the event of any such delay. Therefore, the CONTRACTOR shall pay to the City:

- FIVE HUNDRED DOLLARS (\$500.00) for each and every working day delay after the thirtieth (30) working day completion time limit.

In finishing the work in excess of the dates prescribed and the City shall further have the right to charge to the CONTRACTOR, his heirs, assigns or sureties and to deduct from the final payment for the work, all or any part as it may deem proper of the actual cost of which are directly chargeable to the contract and which accrue during the period of such extensions, except that the cost of the final surveys and preparation of final estimate shall not be included in such charges.

The City may deduct this amount from any money due or that may become due the CONTRACTOR under the contract. This payment shall not be considered as a penalty, but as liquidated damages suffered by the City on account of the failure of the CONTRACTOR to complete the work within the time limit of the contract.

SECTION 7: EXCUSABLE DELAYS

The CONTRACTOR shall not be assessed with liquidated damage nor the cost of Project Coordinating inspection during any delay in the completion of the work caused by acts of God, the public enemy, fire, floods, epidemics, quarantine restrictions, strikes, freight embargoes, unusually severe weather, or due to such causes, provided that the CONTRACTOR shall within ten (10) days from the beginning of such delay notify the City Project Coordinator in writing of the causes of delay. The City Project Coordinator's findings of the facts thereon shall be final and conclusive.

SECTION 8: INTENT OF THE PLANS AND SPECIFICATIONS

The intent of the plans and specifications is to prescribe a complete outline of work, which the CONTRACTOR undertakes to do in full compliance with the contract.

The CONTRACTOR shall furnish all required materials, equipment, tools, labor and incidentals, unless otherwise provided in the contract and shall include the cost of these items in the contract unit prices for the several units of work. All items of work called for on the plans or in the specifications and not included as a separate item in the proposal shall be considered as incidental to the other items listed in the proposal and the payment for such incidental items shall be considered as included in the contract unit prices bid.

SECTION 9: AUTHORITY OF THE PROJECT COORDINATOR AND INSPECTOR

All work shall be done under the supervision of the Project Coordinator acting on behalf of the City. The City Project Coordinator shall decide all questions that arise as to the quality and acceptability of materials furnished, work performed, manner of performance, rates of progress, interpretation of the plans and specifications, acceptable fulfillment of the contract and compensation under the specifications. He shall determine the amount of work performed and materials furnished, and his decision and estimate shall be final. The City Project Coordinators estimate shall be "condition precedent" to the right of the CONTRACTOR to receive money due him under the contract. The City Project Coordinator does not have authority to authorize changes in plans and specifications without prior written approval of the Engineer.

The City shall provide an inspector who will represent the City and shall make inspections of all work, sample and test materials and do such other work relative to supervision of the project as he may be assigned by the City. All instructions given by the inspector are subject to approval by the City Project Coordinator.

SECTION 10: CHANGE ORDERS

The City of Sparks reserves the right to make alterations or supplements to the Contract. Change Order Forms are required for all changes in decreases and/or increases of quantities and/or dollar amount changes in accordance with the Standard Specifications and required by the City of Sparks.

SECTION 11: COOPERATION WITH OTHER CONTRACTORS

The CONTRACTOR shall cooperate with other CONTRACTOR's who may be employed by the City on construction of other work adjacent to or in the proximity of the location of the project.

SECTION 12: SUBLETTING OF CONTRACT

Perform with own organization, work amounting to not less than 30% of the combined value of all items of the work covered by the contract except as follows:

- (a) If electing to furnish materials for work to be performed by an approved subcontractor and the materials are not obtained from the same firm that is to perform the work of incorporating said materials into the project, the cost of said materials, when set forth in a written statement accompanying the subcontract agreement or contained therein, will be excluded from amounts applicable to the subcontracted percentage.

When a firm both sells materials to a Contractor and performs the work of incorporating the materials into the project, these 2 phases of work must necessarily be considered in combination and, as in effect, constituting a single subcontract.

- (b) When performed by subcontract, any items that have been selected as "Specialty Items" for the contract will be excluded from amounts applicable to the subcontracted percentage. "Specialty Items" for the contract will be listed as such in the Special Provisions.

The contract amount bid for "Specialty Items" so performed by subcontract will be deducted from the original total contract price before computing the amount of work required to be performed by the Contractor with his own organization.

Roadside production of materials is construed to be the production of crushed stone, gravel, or other material with portable or semi-portable crushing, screening, or washing plants, established or reopened in the vicinity of the work for the purpose of supplying materials to be incorporated into the work. Roadside production of materials will be considered subcontracting if performed by other than the Contractor.

The City of Sparks and the Contractor will not recognize any subcontractor on the work as a party to the contract. Nothing contained in any subcontract shall create any contractual relation between the subcontractor and the Local Agency. The Contractor will be held solely responsible for the progress of the work according to the progress required.

Insert in each subcontract all of the following contract provisions, copies of which are contained in the contract documents:

- (a) LABOR PROVISIONS: The "DESIGNATED HOURLY MINIMUM WAGE RATES" supplied by the United States Department of Labor and the Labor Commissioner of the State of Nevada.
- (b) FORM FHWA-1273: The "REQUIRED CONTRACT PROVISIONS FEDERAL-AID CONSTRUCTION CONTRACTS (Exclusive of Appalachian Contracts)", "Appendix A of Department of Transportation Order 1050.2A" and "Appendix E of Department of Transportation Order 1050.2A."

- (c) The “ADDITIONAL CONTRACT PROVISIONS—SUPPLEMENT TO THE WEEKLY CERTIFIED PAYROLLS.”
- (d) The “STANDARD FEDERAL EQUAL EMPLOYMENT OPPORTUNITY CONSTRUCTION CONTRACT SPECIFICATIONS (EXECUTIVE ORDER 11246).”
- (f) The certification on “RESTRICTIONS ON LOBBYING USING APPROPRIATED FEDERAL FUNDS.”
- (g) The “AFFIDAVIT REQUIRED UNDER 23 USC SECTION 112(c) and 2 CFR PARTS 180 AND 1200 – SUSPENSION AND DEBARMENT”

SECTION 13: DISADVANTAGED BUSINESS ENTERPRISES

The bidder's attention is directed to the Code of Federal Regulations, 49 CFR, Part 26. This project is subject to 49 CFR, Part 26 entitled "Participation by Disadvantaged Business Enterprises in Department of Transportation Programs; Final Rule." The Contractor agrees to ensure that disadvantaged business enterprises as defined in 49 CFR, Part 26 have an equal opportunity to participate in the performance of the contracts and subcontracts financed in whole or in part with Federal funds. The requirements for compliance are contained in Subsections of the bid package.

The goal established for this project is 6.25%.

Bidders are required to submit the Bidder Disadvantaged Business or Small Business Enterprise (DBE/SBE) Information form before award of the project. Good Faith Effort (GFE) supplemental documentation must also be submitted to City of Sparks before award of the project.

SECTION 14: DISPOSAL OF EXCESS AND WASTE MATERIALS

Trash, construction debris, cleared vegetation, excavated material unsuitable to be incorporated in the construction shall become the property of the CONTRACTOR and shall be removed by the CONTRACTOR and shall be legally disposed of offsite in accordance with all federal, state and local regulations. All street grindings and pulverized material that will be exported will become the property of the contractor. Hauling and disposal will be at the contractor's expense.

SECTION 15: LIMITS OF CONTRACTOR'S OPERATIONS

If the CONTRACTOR's operations result in damage to any publicly or privately owned facilities outside the limitations of the construction easement, the CONTRACTOR shall, at his expense, repair such damage or indemnify the owner of the damaged property.

If the CONTRACTOR negotiates with property owners for the use of land for construction operations outside the limits of the construction easements, he shall do so at his own risk and the City will assume no liability for such use of private property. All agreements between the CONTRACTOR and private property owners shall be in writing and the City will be furnished copies of such agreements.

At no time will the CONTRACTOR be allowed to store debris or materials on the street overnight. All asphalt, concrete, soil and aggregate base will be hauled off at the conclusion of each working day. Materials for installation of Drop Inlets (Pipe, boxes frame and cover) will be allowed to be stored onsite with the approval of the City Project Coordinator or inspector.

SECTION 16: PROTECTION OF EXISTING UTILITIES

The location of existing utilities and drain lines shown on the plans are not guaranteed, but indicates generally their location according to the best knowledge of the Project Coordinator. The CONTRACTOR

shall notify Underground Services Alert (USA Dig) at 1-800-227-2600, and NV Energy, Truckee Meadows Water Authority (TMWA), SBC, Charter Communications and other cable companies not less than five (5) working days prior to the start of construction to verify the location and depths of utilities.

The CONTRACTOR shall inform himself of the exact location of all vaults, boxes, conduits, ducts, cables, pipe systems, etc. and shall protect said utilities. Any damage caused by operation of the CONTRACTOR shall be repaired by the CONTRACTOR at his own expense. It shall be the CONTRACTOR's responsibility to contact the impacted utility for any replacement hardware.

SECTION 17: CONTRACT AMOUNT

The total amount payable under this contract shall be determined by the sum of the amounts earned and the various quantities of repairs actually made and determined from unit prices as furnished by the CONTRACTOR in the schedule of prices contained in his proposal. The various quantities of repairs in the bid proposal are estimates and the City of Sparks reserves the right to vary quantities as may be necessary.

SECTION 18: PRECONSTRUCTION CONFERENCE

After the execution of the contract, but prior to the commencement of any work, a preconstruction conference between the CONTRACTOR and the city will be held at a mutually acceptable time and place.

SECTION 19: MEASUREMENT FOR PAYMENT

Whenever possible, the actual quantities installed or work performed on any project shall be measured on the site of the work by a crew composed of both the CONTRACTOR and the City Project Coordinator. This combined crew shall record all measured quantities in field notebooks, in legible and understandable entries. The CONTRACTOR and the City Project Coordinator shall each have a set of field notes which are to be in agreement on all quantities and items measured and shall include all work accomplished on the project under contract. Each set of field measurements shall be initialed and dated by responsible representatives of the CONTRACTOR and the City Project Coordinator participating on the combined crew. In the event that it is not possible to form a combined crew for the measurements, the area repaired shall be measured by the City Project Coordinator.

SECTION 20: PROMPT PAYMENT AND RETAINAGE CLAUSE

The prime contractor shall pay each subcontractor for satisfactory performance of the subcontractor's contract no later than **10** days from the receipt of each payment the prime contractor receives from the City of Sparks. The prime contractor agrees further to return retainage payments to each subcontractor within **10** days after the subcontractor's work is satisfactorily completed in accordance with 49 CFR 26.29(b)(2). For the purposes of this Subsection, satisfactory completion is defined as the following conditions: (a) Satisfactory completion of the subcontractor's scope of work as described in the contract documents; (b) Receipt of payment for subcontractor's scope of work; (c) Release of claims from subcontractor's laborers, material and equipment suppliers, and lower tier subcontractors; (d) Payment, if applicable, of all union benefits or to employee trust accounts.

The City of Sparks' contracted payroll tracking system is LCP Tracker.

SECTION 21: B2GNOW REPORTING

Contractor shall report payments made to each subcontractor via B2GNow reporting software by the 15th day of each month following payment. Access to the software is provided at no cost. Attach proof of payment for all Enterprise Subcontractors. Ensure that subcontractors report their payments to lower-tier subcontractors via B2GNow. Ensure that Enterprise Subcontractors verify payments made to them via

B2GNow. Reporting via B2GNow is considered a necessary portion of the work and payments may not be forthcoming until this requirement is complied with.

SECTION 22: SURFACE MOUNTED UTILITY ADJUSTMENT

It shall be the CONTRACTOR's responsibility to adjust all surface mounted utility appurtenances, such as manholes, survey monument covers and valve boxes to grade consistent with the grade of the restored surface.

SECTION 23: PRE/POST-CONSTRUCTION WALK-THRU

The CONTRACTOR, Inspector, and/or City Project Coordinator shall conduct a pre and post construction walk-thru. This shall be accomplished to determine limits of construction and existing conditions at each site and the surrounding area. The CONTRACTOR should walk the site and note all existing conditions. Concrete pavers, mow strips, fencing, edging, sprinklers block and brick walls, etc. are within this area. Any damage and finish back to these landscapes will be included within the scope of work and no additional pay item will be allowed for this work.

The CONTRACTOR will be required to video tape the entire project prior to any construction including all effected properties and staging locations. This video media will be in a DVD format and a copy of the DVD will be provided to the City. Areas near the property lines, back of sidewalk and driveways, landscaping, mow strips, fences and edging should be videoed in great detail to avoid any damage or disputes with property owners. The CONTRACTOR will be required to replace and or repair all areas that damaged by construction activities. Areas that are in question or concern should be noted on the video and the CONTRACTOR should notify the City Project Coordinator or inspector.

SECTION 24: WORKING DAY, WORK HOURS, SATURDAY, SUNDAY, HOLIDAY AND OVERTIME WORK

Sparks Municipal Code 20.04.005.D restricts construction hours to 5:00 A.M. until 7:00 P.M., Monday through Friday and 8:00 A.M. until 5:00 P.M. on Saturday. For this project, the defined construction hours will be 7:00 A.M. until 7:00 P.M., Monday through Friday unless otherwise required by these specifications or requested by the City Project Coordinator. The CONTRACTOR shall not commence Construction operations before seven o'clock (7:00 A.M. Pacific Time) each working day except as directed by the City Project Coordinator and as specified herein.

The CONTRACTOR shall not perform any contract work on Saturday, Sunday, legal Holidays and outside of the twelve (12) hours available during a regular working day except as directed and approved by the city Project Coordinator and as specified herein.

When directed to or requesting to work outside of the legally permitted construction hours defined above, the CONTRACTOR shall first obtain approval from the City Project Coordinator at least seventy-two (72) hours prior to commencing such overtime work. If the CONTRACTOR plans to perform work on Saturday or Sunday, he/she shall obtain approval by the Wednesday prior to work on the Saturday or Sunday for which work is planned. If the CONTRACTOR plans to perform work on a legal Holiday, he/she shall first obtain approval from the City Project Coordinator at least 72 hours in advance.

CONTRACTOR shall obtain approval through the Temporary Use Permit (T.U.P.) and pay a fee of one hundred (\$100.00) dollars to work outside of the above legally permitted construction hours. The request shall include justification of how public safety or project performance will be enhanced through working outside of the restricted construction hours. Submittal and payment of fees does not guarantee approval.

The CONTRACTOR shall be charged for all of City of Sparks' employee(s) time spent for overtime, Saturday, Sunday or Holiday work, based on the employee's hourly rate, plus benefits. The

CONTRACTOR will be notified of the costs incurred and if the payment is not made, such costs will be deducted from any payment due to the CONTRACTOR. In addition to the charge for the City employee(s) time outside a standard workday,

The City of Spark recognizes the following legal Holidays:

January 1	New Year's Day
3 rd Monday in January	Martin Luther King, Jr. Birthday
3 rd Monday in February	President's Day
Last Monday in May	Memorial Day
3 rd Monday in June	Juneteenth
July 4	Independence Day
1 st Monday in September	Labor Day
Last Friday in October	Nevada Day
November 11	Veteran's Day
4 th Thursday in November	Thanksgiving Day
4 th Friday in November	Family Day (day after Thanksgiving)
December 25	Christmas Day

SECTION 25: SUBMITTALS

Submittals for the following items shall be provided at the time of the preconstruction meeting and shall have been performed within the previous 12 months. Two (2) copies of each item should be submitted.

- New Aggregate Base
- Portland Cement Concrete Mix Design
- ADA Truncated Dome Warning Panel
- Concrete Curing Compound

SECTION 26: DIFFERING SITE CONDITIONS

During the progress of the work, if subsurface or latent physical conditions are encountered at the site differing materially from those indicated in the contract or if unknown physical conditions of an unusual nature, differing materially from those ordinarily encountered and generally recognized as inherent in the work provided for in the contract, are encountered at the site, the party discovering such conditions shall promptly notify the other party in writing of the specific differing conditions before the site is disturbed and before the affected work is performed.

Upon written notification, the engineer will investigate the conditions, and if it is determined that the conditions materially differ and cause an increase or decrease in the cost or time required for the performance of any work under the contract, an adjustment, excluding anticipated profits, will be made and the contract modified in writing accordingly. The engineer will notify the contractor of the determination whether or not an adjustment of the contract is warranted.

No contract adjustment which results in a benefit to the contractor will be allowed unless the contractor has provided the required written notice.

No contract adjustment will be allowed under this clause for any effects caused on unchanged work.

SECTION 27: SUSPENSIONS OF WORK ORDERED BY THE ENGINEER

If the performance of all or any portion of the work is suspended or delayed by the engineer in writing for an unreasonable period of time (not originally anticipated, customary, or inherent to the construction

industry) and the contractor believes that additional compensation and/or contract time is due as a result of such suspension or delay, the contractor shall submit to the engineer in writing a request for adjustment within 7 calendar days of receipt of the notice to resume work. The request shall set forth the reasons and support for such adjustment.

Upon receipt, the engineer will evaluate the contractor's request. If the engineer agrees that the cost and/or time required for the performance of the contract has increased as a result of such suspension and the suspension was caused by conditions beyond the control of and not the fault of the contractor, its suppliers, or subcontractors at any approved tier, and not caused by weather, the engineer will make an adjustment (excluding profit) and modify the contract in writing accordingly. The contractor will be notified of the engineer's determination whether or not an adjustment of the contract is warranted.

No contract adjustment will be allowed unless the contractor has submitted the request for adjustment with the time prescribed.

No contract adjustment will be allowed under this clause to the extent that performance would have been suspended or delayed by any other cause, or for which an adjustment is provided or excluded under any other term or condition of this contract.

SECTION 28: SIGNIFICANT CHANGES IN THE CHARACTER OF WORK

The engineer reserves the right to make, in writing, at any time during the work, such changes in quantities and such alterations in the work as are necessary to satisfactorily complete the project. Such changes in quantities and alterations shall not invalidate the contract nor release the surety, and the contractor agrees to perform the work as altered.

If the alterations or changes in quantities significantly change the character of the work under the contract, whether such alterations or changes are in themselves significant changes to the character of the work or by affecting other work cause such other work to become significantly different in character, an adjustment, excluding anticipated profit, will be made to the contract. The basis for the adjustment shall be agreed upon prior to the performance of the work. If a basis cannot be agreed upon, then an adjustment will be made either for or against the contractor in such amount as the engineer may determine to be fair and equitable.

If the alterations or changes in quantities do not significantly change the character of the work to be performed under the contract, the altered work will be paid for as provided elsewhere in the contract.

The term "significant change" shall be construed to apply only to the following circumstances:

When the character of the work as altered differs materially in kind or nature from that involved or included in the original proposed construction; or

When a major item of work, as defined elsewhere in the contract, is increased in excess of 125 percent or decreased below 75 percent of the original contract quantity. Any allowance for an increase in quantity shall apply only to that portion in excess of 125 percent of original contract item quantity, or in case of a decrease below 75 percent, to the actual amount of work performed.

SECTION 29: BUY AMERICA

In accordance with Title 23 CFR 635.410, permanently incorporated steel and/or iron materials on Federal-Aid projects shall be domestically produced regardless of the percentage they comprise in a manufactured product or form they take.

Minimal use of foreign steel materials will be permitted provided the cost of said materials does not exceed 1/10 of 1% of the total contract cost or \$2,500.00, whichever is greater. The combined cost of foreign steel and/or iron materials will be the value of the materials as they are delivered to the contract, documented by invoice or bill of sale to the contractor. Submit for review a request to use foreign materials prior to their use. Do not incorporate any foreign steel materials into the project without approval.

To qualify as domestic steel, all manufacturing processes, including manufacture, fabrication, grinding, drilling, welding, finishing, coating, and assembly of product containing steel and/or iron materials, must have been performed in the United States. To further define the coverage, a domestic product is a manufactured steel and/or iron materials construction material that was produced in one of the 50 states, the District of Columbia, Puerto Rico, or in the territories or possessions of the United States. Raw materials used in the steel and/or production may be imported. Raw materials such as iron ore, limestone, waste products, etc. which are used in the manufacturing process to produce steel and/or iron materials products. Waste products include scrap; i.e., steel no longer useful in its present form from old automobiles, machinery, pipe, railroad rail, steel trimmings from mills or product manufacturing, and the like. Extracting, crushing, and handling the raw materials which are customary to prepare them for transporting are exempt from Buy America. The use of foreign steel or iron billets is not acceptable under Buy America.

The Build America, Buy America Act (BABA) of the Infrastructure Investment and Job Act (IIJA) (Pub. L. No. 117-58 §§ 70901-52) expands the requirements of the Buy America Act to include permanently incorporated construction materials on Federal-aid projects.

A “construction material” as defined under BABA shall include any article, material, or supply - other than an item of primarily iron or steel; a manufactured product; cement and cementitious materials; aggregates such as sand, stone, or gravel; or aggregate binding agents or additives - that is or consists primarily of the following:

1. Non-ferrous metals;
2. Plastic and polymer-based products, including but not limited to polyvinylchloride, composite building materials, and polymers used in fiber optic cables;
3. Glass (including optic glass);
4. Lumber; or
5. Drywall

Items that consist of two or more of the listed materials that have been combined together through a manufacturing process, and items that include at least one of the listed materials combined with a material that is not listed through a manufacturing process, should be considered as manufactured products rather than construction materials.

All construction materials must be manufactured in the United States. This means that all manufacturing processes for the construction material occurred in the United States.

Provide a Certificate of Materials Origin, using NDOT form 020-095, certifying materials comply with the Buy America requirements as specified above. Submit the certification prior to installation of the material. Unless a Certificate of Materials Origin has been provided, the materials will be considered of foreign origin.

SECTION 30: TRAFFIC CONTROL PLANS

All traffic control shall conform to the latest editions of the NDOT Work Zone Traffic Control Handbook and the Manual on Uniform Traffic Control Devices (MUTCD) and as directed by the City Project Coordinator.

The CONTRACTOR shall designate a Traffic Control Supervisor (TCS), certified by the American Traffic Safety Services Association (ATSSA), who shall be responsible for planning, initiating, installing and maintaining all traffic control devices, as shown on the traffic control plan, as specified in the MUTCD and these specifications. The designated construction TCS shall be available to be contacted twenty-four (24) hours a day, seven (7) days a week, for the life of this Contract.

The traffic control plan shall scaled such that all proposed signage and traffic control for all streets in the entire unit can be seen on one full size (24"x 36") or half size (11"x17") plan sheet. The CONTRACTOR shall submit two (2) copies of proposed traffic control plan to the City Project Coordinator for review and comments five (5) working days prior to the pre-construction meeting. The proposed traffic control plan shall be prepared and signed by a certified TCS, retained by the CONTRACTOR.

The CONTRACTOR's traffic control plans shall include, but not be limited to, the following:

- Proposed construction zone and existing speed limits
- All construction signing
- Message board locations
- Location of flaggers
- Types and locations of traffic control devices
- Temporary lane striping
- Construction phasing
- Lane crossovers between construction phases
- Method for maintaining traffic signal functions
- Special events accommodations
- Detours
- Accommodations for pedestrian, bicycle, and transit facilities

If, during construction, revisions to the accepted plan is necessary or safety or accommodation to traffic, these changes must also be prepared by the ATSSA certified, Traffic Control Supervisor.

The City Project Coordinator may authorize a suspension of work during unfavorable weather or other conditions beyond the control of the CONTRACTOR. During such a suspension, the CONTRACTOR shall make passable and shall open to traffic such portions of the project under improvement and such temporary roadways or portions thereof as may be agreed upon between the CONTRACTOR and the City Project Coordinator for the accommodation of necessary traffic during the period of suspension. The maintenance of the temporary route, replacement or renewal of any work or materials lost or damaged, removal of any work or materials and temporary maintenance shall be at the expense of the CONTRACTOR.

Existing roadways will only be allowed to be closed to thru traffic only. Flaggers will be required if the City Project Coordinator believes it is needed due to current activity or traffic safety. Failure to comply with Flagger requirements will result in an immediate shut down of all construction activity. Work will resume when the flagger requirement has been satisfied.

During non-working hours any hazardous section of the work shall be outlined with markers and flares. If deemed necessary by the City Project Coordinator, barricades shall be erected to protect public traffic or he may direct the CONTRACTOR to furnish flagger(s) and pilot cars. Such markers, flares, barricades, flagging or piloting shall be at the expense of the CONTRACTOR.

When the CONTRACTOR's hauling equipment is required to merge with a cross traffic and at such other points which may be necessary to maintain safe traffic conditions, flaggers shall be provided to each side of the impairment to stop and direct traffic.

In case of damage to detours due to storms or other causes, the CONTRACTOR shall at once repair the damage, provide other detours or provide for carrying traffic through construction operations. Water shall be applied at points and in amounts as directed by the City Project Coordinator, to keep the roadbed firm, smooth, stable and to reduce the dust hazard to a minimum.

Construction Zone Signs shall be placed on all cross streets where traffic is to be maintained. They shall be placed a sufficient distance from the construction to give motorist's adequate warning of the construction. None of the provisions herein shall be construed to restrict or prohibit, at any time, the prosecution of items of work, which will not interfere with the use of existing streets.

All flagging, piloting, signs, barricades, maintenance of work, streets, structures, detours, temporary approaches, replacement or renewal of work, water applied for these items or for dust control, shall not be paid for directly, but shall be included in various pay items of the proposal and the CONTRACTOR shall not be paid an additional amount for such work. When so ordered by the City Project Coordinator, detours shall be surfaced and the materials needed shall be paid for by the cubic yard or ton as set forth in the pay items of the proposal.

SECTION 31: STORMWATER CONSTRUCTION GENERAL PERMIT / TEMPORARY WORKING IN WATERWAYS PERMIT

A stormwater construction general permit (CGP) may be required for the project, at the discretion of the Nevada Division of Environmental Protection (NDEP). A CGP will be needed if the project disturbs one or more acres and may be needed if disturbance occurs within ¼ mile of a Waters of the U.S. (note that North Truckee Drain is a tributary to the Truckee River, a Waters of the U.S.). When the construction contract is awarded, the contractor will need to contact NDEP to determine if GCP coverage is needed.

If driven equipment is operated within any waters of the state a Temporary Working in Waterways Permit (issued by NDEP) will be required. This is a contractor-obtained permit.

SECTION 32: MIGRATORY BIRD TREATY ACT (MBTA) AND BATS

Vegetation/structure removal shall be conducted to conform with the MBTA to avoid impacts to listed migratory birds (50 CFR 10.13) that may be actively utilizing vegetation or structures for nesting. When possible, vegetation and structure removal should not occur during avian breeding season (generally March 1 through July 31), but raptors and owls may begin nesting as early as January. As these dates are a general guideline, active nests may be observed outside this range. If vegetation or structure removal must occur during avian breeding season, nesting surveys must be conducted by a qualified biologist. If nesting sites are found within the project limits, US Fish and Wildlife must be consulted to determine a suitable buffer area around the nest site. Buffer areas around the nest site should be flagged as an avoidance area and no disturbance should occur within the avoidance area while the nest is occupied with eggs or young. Once young have left the nest, the avoidance area can be removed, and work can resume.

If bats are identified roosting within the permitted area, contact the Nevada Department of Wildlife (NDOW) for proper guidance. An avoidance area with a 100' radius must be maintained until formal guidance is received. For information on how to contact NDOW go to: http://www.ndow.org/Our_Agency/Contact_Us/

SECTION 33: NOXIOUS WEED MANAGEMENT

Prevent the establishment and spread of Nevada State listed noxious weeds per NRS 555.

SECTION 34: ARCHEOLOGICAL RESOURCES

Be responsible for the preservation of archeological and paleontological objects, including all ruins, sites, buildings, artifacts, fossils, or other objects of antiquity encountered during construction. When such objects are encountered, immediately cease operations within 100 feet of the discovery and give notification to the City Project Coordinator that such objects exist. The City Project Coordinator will notify the Manager of NDOT's Cultural Resource Section. Reschedule construction operations to avoid the section until given written notification from the City Project Coordinator to proceed with operations.

SECTION 35: CLEANUP AND DUST CONTROL

It shall be the CONTRACTOR's responsibility to provide cleanup and dust control throughout all phases of construction, including suspension of work, and until final acceptance of the project. The CONTRACTOR shall keep the work site and other adjacent areas clean and free from rubbish and debris. The CONTRACTOR shall also abate dust nuisance by cleaning, sweeping, and sprinkling with water, or other means as necessary. A power broom will not be an acceptable means of cleaning the site unless used in conjunction with water to prevent dust from the power broom operation. The use of water resulting in mud on public streets will not be permitted as a substitute for sweeping or other methods. All water used for dust control must be from a potable water source.

All construction procedures shall conform to WCDHD-AQMD standards.

Excess excavated material from trenches, manholes, catch basins or similar structures in public streets shall be removed from the site immediately. Sufficient material may remain for use as backfill, but shall not remain during non-working hours. Forms and form lumber shall be removed from the site as soon as practical after stripping. No screening of excavated material will be allowed in the street. The CONTRACTOR shall remove all trash from the site in a timely manner. At no time shall the CONTRACTOR permit disposal of trash in any excavation.

Materials and equipment shall be removed from the site as soon as they are no longer necessary; and, upon completion of the work and before final inspection, the entire worksite shall be cleared of equipment, waste and unused materials, construction debris and rubbish so as to present a satisfactory clean and neat appearance.

Care shall be taken to prevent spillage on haul routes. Any such spillage shall be removed immediately and the area cleaned.

Failure of the CONTRACTOR to comply with the City's cleanup orders may result in an order to suspend work until the condition is corrected. Working days will continue to be counted during the suspension. No additional compensation will be allowed as a result of such suspension. No extension of contract time will be allowed as a result of such suspension.

If the contract time expires before final cleanup has been completed, liquidated damages, as specified in these Special Provisions, may be imposed.

SECTION 36: OSHA/MSDS REQUIREMENTS

In compliance with the multi-employer worksite provisions of the Occupational Safety and Health Administration's (OSHA) Hazard Communication Standard 29 CFR Part 1910.1200 (e) (2) the Contractor is required to provide current Safety Data Sheets (SDS) for all hazardous chemicals [as defined in 29 CFR Part 1910.1200 (c)] to be used by the Contractor in this contract. It will be the Contractor's responsibility to submit a list of all hazardous chemicals to be used on this contract 7 days in advance of the pre-

construction conference. SDS must be submitted prior to the beginning of any phase of work which requires the use of the hazardous chemical. An SDS shall be submitted prior to use of the hazardous chemical on the contract, for any additional hazardous material not covered by the original list.

SECTION 37: AIR QUALITY STATEMENT

This project is located in Washoe County, Nevada. The bidder shall contact the Washoe County District Health Department (Air Quality Division) regarding special considerations concerning air quality requirements in the county.

SECTION 38: FORCE ACCOUNT

THIS ITEM SHALL BE IDENTIFIED AS A CONTINGENT ITEM. The use of this contingent item will be as directed by the City Project Coordinator. The quantity of the above contingent item of work, as set forth on the bid schedule represent no actual estimate, is nominal only and may be greatly increased or decreased or reduced to zero. The increase or reduction of this quantity as compared with that set forth on the bid schedule shall not constitute a basis for claim by the CONTRACTOR for extra payment or damages.

Force Account items as defined by the City of Sparks will be additions to the contract arising within the course and scope of the contract for incidental costs due to unforeseen circumstances. Unforeseen circumstances include but are not limited to the following:

Emergency repairs, complications arising with interfacing new improvements to existing improvements, emergency pumping, emergency light/power plants, premium time or overtime to accelerate portions of work, unexpected utility modifications or conflicts, correcting existing substandard work, requested traffic control measures or signage, over-excavation of unsuitable materials, unknown field conditions, underground storage tanks, asbestos encountered, or any other miscellaneous or incidental items related to unforeseen circumstances.

Any force account items shall be adjusted daily upon report sheets, furnished to the City Project Coordinator by the CONTRACTOR and signed by both parties. These daily reports shall thereafter be considered the true record of force account items for unforeseen circumstances. No additional incidental work shall be performed or made except upon a written order from the City Project Coordinator.

SECTION 39: INSURANCE AND INDEMNIFICATION

The CONTRACTOR shall not commence any work nor permit a Subcontractor to commence work on this project until satisfactory proof has been presented to the City of Sparks Purchasing Division that all insurance requirements as outlined by the City have been met.

The CONTRACTOR shall provide and maintain, during the effective life of the awarded contract, Comprehensive General Liability Insurance covering the CONTRACTOR and the City of Sparks.

SECTION 40: LOCATION OF WORK, PUBLIC RELATIONS

It shall be the CONTRACTOR'S responsibility to notify, in writing, all residents and businesses adjacent to this project of the construction working hours and duration of work. Notification shall be provided directly to impacted properties (i.e. properties abutting the work) seven (7) calendar days prior to beginning work at that location **excepting** notification for Monday and Tuesday work shall be provided no later than 7:00 PM Thursday. Notification shall be in the form of a "door hanger" or flyer that is hand-delivered by the CONTRACTOR to each residence/business. A copy of the written communication must be provided to the City Project Coordinator and approved before being dispersed.

Special consideration shall be given to schools to accommodate schedules for pedestrians, student drop-off, and busses.

“NO PARKING” signs shall be displayed on streets at least 24 hours prior to operations. Signs shall be legible from inside vehicles and state the day and dates work will be performed. Signs shall be free from defects and unbroken.

In the event of delays that require rescheduling of work, the CONTRACTOR shall re-notify impacted properties in the same manner as described in the paragraphs above.

SECTION 41: MATERIAL TESTING AND QA/QC STANDARDS

Compaction testing and concrete testing will be provided by the city. 24-hour notice must be given by the contractor to the City project coordinator prior to any testing. Three copies of aggregate base and concrete submittals will be required for approval prior to any installation.

The City of Sparks will utilize the NDOT Construction Manual, NDOT Documentation Manual, and the Standard Specifications for Public Works Construction (Orange Book) for the project, with the following requirements.

- The City of Sparks will comply with the Orange Book Section 336, requiring that the City’s testing lab is AASHTO Accredited.
- All material testing staff will be certified for the tests they are performing (i.e. NAQTC/WAQTC, ACI, etc.)
- Minimum testing frequencies from Orange Book Section 336 must be followed.
- The City of Sparks will be responsible for acceptance testing.

SECTION 42: POSTINGS AND NOTICES

Notices and posters are to be placed in:

- areas readily accessible to the public and employees (per 23 CFR 230.121);
- on the site of the public work in a place generally visible to the workmen (per NRS 338.020);
- shall be posted at all times by the contractor and its subcontractors at the site of the work in prominent and accessible place where it can be easily seen by the workers...on bulletin boards accessible to all employees at each location where construction work is performed (41 CFR 60-4.3); and
- according to Section 110.01 of the Standard Specifications for Road and Bridge Construction, the contractor is to provide and erect a weatherproof bulletin board at the job site and post all required information thereon.

Required Postings:

1. The EEO policy statement with the appointment of the EEO officer with their contact information.
2. Prevailing Wage Rates (both State and Federal) specific to the project.
3. Current Federal postings and notices found here:
<https://www.fhwa.dot.gov/programadmin/contracts/poster.cfm>
4. Current State postings and notices can be found here:
http://labor.nv.gov/Employer/Employer_Posters/
5. A List of Emergency services phone numbers. If the project is in a 911 accessible area, post a notice that 911 should be called in an emergency.

The prime contractor is responsible for providing a weatherproof bulletin board or fixture to display EEO policy information, wage decisions, required State and Federal postings and information on various employee rights, protections and appeals. The bulletin board must be located within the limits

of the project, easily visible to the public and employees (of both the prime and any subcontractors), and be accessible during construction of the project (installed on or before the notice to proceed date and removed at construction completion).

Some projects do not lend themselves to a stationary bulletin board as the project limits are extensive and/or the project moves frequently. In such cases, alternative methods of posting must be determined. The alternative posting method must still meet the requirements of a stationary fixture as above.

The bulletin board or fixture cannot be located inside an office, construction trailer, or in a vehicle. Please consult with the project Resident Engineer or with the Contract Compliance office to assist in determining if a fixture will meet the requirements stated.

SECTION 43: LOCATION OF WORK, PUBLIC RELATIONS

It shall be the CONTRACTOR'S responsibility to notify, in writing, all residents and businesses adjacent to this project of the construction working hours and duration of work. Notification shall be provided directly to impacted properties (i.e. properties abutting the work) seven (7) calendar days prior to beginning work at that location **excepting** notification for Monday and Tuesday work shall be provided no later than 7:00 PM Thursday. Notification shall be in the form of a "door hanger" or flyer that is hand-delivered by the CONTRACTOR to each residence/business. A copy of the written communication must be provided to the City Project Coordinator and approved before being dispersed.

Special consideration shall be given to schools to accommodate schedules for pedestrians, student drop-off, and busses. Approval for pedestrian route closures shall be per the City Project Coordinators discretion.

"NO PARKING" signs shall be displayed on streets at least 24 hours prior to operations. Signs shall be legible from inside vehicles and state the day and dates work will be performed. Signs shall be free from defects and unbroken.

In the event of delays that require rescheduling of work, the CONTRACTOR shall re-notify impacted properties in the same manner as described in the paragraphs above.

BID ITEM CLARIFICATIONS
2024 CITY OF SPARKS PEDESTRIAN RAMP REPLACEMENT PROJECT-
FEDERALLY FUNDED
BID #24/25-001, PWP# WA-2025-008
FEDERAL PROJECT #SI-0032-(381)
NDOT PROJECT #61185

BID ITEM 1 ~ Remove Existing and Construct PCC Type 1 Curb and Gutter

This work shall consist of all labor, equipment, materials, and incidentals necessary, but not limited to, saw cutting adjacent surfaces, removal of the existing PCC curb and gutter, removal of existing materials including asphalt/concrete, existing base / subgrade, including tree roots, to the bottom of the new aggregate base depth, disposing of excavated material in a lawful manner, installation of new Type 2 aggregate base to a depth of six inches (6”) compact to 95% MDD, placement of PCC curb and gutter and removal and replacement of asphalt or concrete adjacent to the PCC Curb & Gutter as needed for transition.

Curb and gutter removal and replacements shall be “neat line” sawcut at the existing asphalt pavement.

The final pay quantity shall be by field measurement unit at the applicable unit price bid per linear foot which shall be deemed full compensation to complete the work as specified.

BID ITEM 2 ~ Remove Existing and Construct PCC Sidewalk

The work shall consist of all labor, equipment, materials, and incidentals necessary, but not limited to, saw cutting adjacent surfaces, the removal of the existing PCC sidewalk and the existing aggregate base and/or subgrade materials, and removal of existing materials, including tree roots, to the bottom of the new aggregate base depth, installation of new Type 2 aggregate base to a depth of four inches (4”) compact to 95% MDD, placement of PCC sidewalk and any grading necessary behind the new sidewalk to achieve a maximum slope of 3:1 and removal and replacement of asphalt or concrete adjacent to the PCC Sidewalk as needed for transition.

Placing plantmix bituminous, PCC patches and/or landscape restoration shall be included in this item at no additional charge. Any existing improvements adjacent to new or replaced driveways that are displaced or damaged, i.e. sod, sprinkler systems, signs, mailboxes, trees, shrubs, other facilities or appurtenances shall be replaced or restored to the original position and condition prevailing prior to the start of operations at the Contractor’s expense.

The final pay quantity shall be by field measurement unit at the applicable unit price bid per square foot which shall be deemed full compensation to complete the work as specified.

BID ITEM 3 ~ Remove Existing and Construct Reinforced PCC Valley Gutter Spandrel

This work shall consist of all labor, equipment, materials, and incidentals necessary, but not limited to, saw cutting, removal of existing materials including asphalt, concrete, rebar, existing base / sub grade, disposing of excavated material in a lawful manner, and installing new concrete reinforced (#4 Rebar, 18” on center) valley gutter spandrel including six inches (6”) of new Type 2 base, compact to 95% MDD and placement per Standard Specifications and Details.

PCC valley gutter spandrel removal and replacements shall be “neat line” sawcut at the existing asphalt pavement.

The final pay quantity shall be by field measurement unit at the applicable unit price bid per square foot which shall be deemed full compensation to complete the work as specified.

BID ITEM 4 ~ Remove Existing and Construct PCC ADA Accessible Ramp

The work shall consist of all labor, equipment, materials, and incidentals necessary, but not limited to, saw cutting adjacent surfaces, excavation and disposal up to 20 feet of existing curb, gutter and sidewalk, along with any unsuitable sub grade material including existing base, installation of new Type 2 aggregate base to a depth of six inches (6”), and placement of a new ADA access ramp including truncated domes and any needed curbing on the back edge of the walkway. Also included in this bid item shall be the replacement of the curb and gutter adjacent to the front side of the ADA access ramp from the top of each wing and removal and replacement of asphalt or concrete adjacent to the PCC ADA Accessible Ramp as needed for transition.

PCC ADA Accessible Ramp removal and replacements shall be “neat line” sawcut at the existing asphalt pavement.

The final pay quantity shall be by field measurement unit at the applicable unit price bid per each which shall be deemed full compensation to complete the work as specified.

BID ITEM 5 ~ Remove and Relocate Street Signs and Post and Furnish

This item of work shall consist of all labor, equipment, materials, and incidentals necessary but limited to, removal of existing materials required and provide all necessary materials for proper re-installation of sign including anchors and posts.

The final pay quantity shall be by field measurement unit at the applicable unit price bid per each which shall be deemed full compensation to complete the work as specified.

BID ITEM 6 ~ Remove and Reinstall Fencing (Contingent)

The unit price bid to demolish existing section of fencing and reinstall new fencing in like kind, shall include all labor, equipment, materials, and all incidentals necessary to remove and for complete installation of such items at the locations indicated on the drawings. Work shall include, but not be limited to, all necessary saw cutting, hardware removal, offsite disposal or salvaging of materials, installation, and incidentals as necessary for a complete removal and reinstallation of the fence section. Remove and Reinstall Fencing shall be considered a contingent item and will not be subject to the 25% rule that is outlined within the Orange Book section 153.00.

The final pay quantity shall be by field measurement unit at the applicable unit price bid per linear foot which shall be deemed full compensation to complete the work as specified.

BID ITEM 7 ~ Force Account

These items are a force account for the purpose of including a reasonably anticipated net increase in the contract amount, approved as necessary by the City of Sparks, for items included in the bid schedule which have increased based on field measured quantities.

The lump sum unit price bid amount of \$25,000.00 for bid item 7 shall be the same for all bidders in accordance with the bid schedule.

There is no direct payment for this item. The FORCE ACCOUNT amount may be used entirely, partially, or not at all.

TECHNICAL SPECIFICATIONS
2024 CITY OF SPARKS PEDESTRIAN RAMP REPLACEMENT PROJECT-
FEDERALLY FUNDED
BID #24/25-001, PWP# WA-2025-008
FEDERAL PROJECT #SI-0032-(381)
NDOT PROJECT #61185

Unless otherwise amended in these Technical Specifications, all materials, construction methods, etc. shall follow the Standard Specifications for Public Works Construction (Orange Book), 2012 version.

300 CLEARING AND GRUBBING

300.02.03 Protection of plants. Trimming and Root Mitigation - If existing landscaping (trees, shrubs, roots, branches, etc.) encroach into the public right-of-way and interfere with construction activity, the contractor shall notify the adjacent property owner and the City of Sparks before commencing any landscaping modifications such as pruning, trimming, or removal of landscaping. City of Sparks Public Works Manager, Mark Andersen (775) 353-2271, shall be notified within three (3) days' notice of work to be performed. The Contractor shall employ an ISA certified Arborist to perform root crown excavation/root pruning and shall coordinate this through the Urban Forester.

300.05 Basis of payment. There shall be NO DIRECT PAYMENT for clearing and grubbing. Compensation shall be deemed included in other items of work.

301 REMOVAL OF EXISTING IMPROVEMENTS

301.04.02 Responsibility. This section to include sod, topsoil, decorative rock, and weed barrier fabric. Where lawn or landscape areas have been disturbed, contaminated, or removed, the Contractor shall replace the topsoil with an imported, high quality, garden topsoil. The topsoil shall be free of debris, weeds, harmful substances, and rocks larger than ¾" in any direction. Topsoil shall meet the specifications of 200.08. Where existing lawn is disturbed, it shall be repaired with sod. Grass seed will not be accepted. There will be no direct payment for sod, topsoil, decorative rock, and weed barrier fabric.

Existing facilities whether above or below grade shall be protected from damage by the Contractor's operations.

Any damage shall be repaired to the satisfaction of the City Project Coordinator at the Contractor's expense.

The locations of existing underground utilities shown on the drawings were determined from various sources. It is the Contractor's responsibility to determine the actual location of underground facilities as noted in the design drawings. Potholing shall be required and shall be incidental to the most appropriate bid item.

Irrigation Systems - In the event an existing irrigation system is damaged, it shall be repaired within twenty-four (24) hours; the Contractor shall provide water to the affected area until such time the irrigation is repaired to the satisfaction of the City Project Coordinator. There will be no direct payment for repairing the irrigation system, or watering of the affected area if needed.

Replacement of damaged irrigation parts shall be made with the same brand name and model.

Should the Contractor neglect or fail to repair the damaged irrigation within forty-eight (48) hours then the City Project Coordinator may, after written notice to the Contractor, have the deficiencies repaired and deduct the cost from the monies owed to the Contractor.

301.05 Basis of Payment. There shall be NO DIRECT PAYMENT for the removal of existing improvements. Compensation shall be deemed included in other items of work.

302 SUBGRADE PREPARATION

302.02 Preparation of Subgrade. Subgrade below new plantmix bituminous pavement, PCC sidewalk and/or pedestrian ramps shall be prepared by removing all 4" plus material from the surface and static rolling with a smooth drum roller.

302.07 Basis of payment. There shall be NO DIRECT PAYMENT for excavation and preparation of the subgrade. Compensation shall be deemed included in other items of work.

308 AGGREGATE BASE COURSES

308.02 Materials. Material used for Aggregate Base shall be Type 2, Class B, Aggregate Base per Standard Specifications Subsection 200.01.03.

New Type 2, Class B aggregate base shall be used under concrete curb and gutter, driveway aprons, pedestrian ramps, valley gutter, alley aprons, and sidewalks. Material submitted as Recycled Asphalt Base for use under bituminous pavement shall conform to the Standard Specifications, Subsection 200.01.04, for Type 1, imported, recycled asphalt concrete base.

308.07 Basis of Payment. There shall be NO DIRECT PAYMENT for preparation and placement of aggregate base course. Compensation shall be deemed included in other items of work.

312 CONCRETE CURB, CURB AND GUTTER, SIDEWALK, DRIVEWAY APRONS, AND VALLEY GUTTER SPANDREL

312.01.01 Description. This work shall consist of construction of Portland Cement Concrete curb and gutter, sidewalks, and ADA accessible ramps, including supplying six inches (6") of aggregate base (four inches (4") under sidewalks) per section 308. Sections of curb and gutter shall match existing style and construct to the standard Type I, except as noted below:

- a. In all instances curb and gutter is being removed and replaced on an adjacent roadway the Contractor shall match the existing top of curb and maintain the flow line of the gutter. If the curb height varies, there shall be NO Direct Payment for the additional work and materials to match the existing curb section on either side of the removed item
- b. The replacement of all disturbed landscaping and irrigation, in kind, and any plantmix bituminous pavement patching shall be included in the bid price for the curb and gutter, sidewalk, and ADA accessible ramps.

312.02 Materials. All concrete shall be Type II Portland Cement which shall have: a coarse aggregate gradation conforming to Size 67 in subsection 200.05.03 of the Standard Specifications, between 6 to 8 sacks of cement per cubic yard, a maximum of 5 gallons of water added per sack of cement, a 1 to 4-inch

slump, 6 percent plus or minus 1-1/2 percent entrained air, 0.45 maximum water to cement ratio, and have a minimum 28 day compressive strength of 4,000 psi. **Polypropylene or Cellulose fibers shall be added to the P.C.C at 1.5 LBS. per cubic yard.**

The ADA truncated dome warning panel shall be CASTinTACT3, Tekway Dome Tiles, ADA Solutions, and Access Tile or approved equal. **Domes shall be yellow in color.**

312.03.02.02 Finishing. The base shall be placed, compacted and available for inspection prior to placement of any concrete. The base shall be well-drained and be uniformly graded below finished grade. It must be moistened to a nominal depth, densified to 95% relative compaction and free of frost at the time of placing any concrete. If necessary, the base should be dampened with water just prior to placing concrete, but there shall be no free-standing water on the base surface.

The concrete shall be placed and consolidated to fill all spaces in the forms completely and to provide a suitable surface for finishing. The concrete adjacent to the forms shall be tamped to eliminate excess voids. Water must not be sprayed on the surface to re-temper the plastic concrete for toweling. Hard steel toweling shall be minimized to avoid trowel burns.

When concrete is placed in hot, cold or windy conditions, precautions must be taken to prevent cracking resulting from excessively rapid drying or freezing at the surface.

Expansion joints ½ wide will NOT be placed in the curb and gutter unless otherwise directed by the City Project Coordinator.

Transverse expansion joints ½ inch wide will NOT be placed in the sidewalk unless otherwise directed by the City Project Coordinator. New sections of sidewalk shall be doweled into the existing adjacent concrete sidewalk with a minimum of two (2) No. 4 reinforcing bars equally spaced across the width of the sidewalk. Dowels shall penetrate a minimum of 4-inches into existing concrete. Epoxy will not be required.

312.03.02.03 Curing. Immediately after finishing operations have been completed, all exposed surfaces shall be sealed by applying an impervious curing compound membrane. Within 30 minutes after form work is removed, the concrete surface covered by the form shall be coated with curing compound.

The liquid curing compound shall conform to the requirements of the Standard Specifications for Liquid Membrane-Forming Compounds for Curing Concrete meeting both ASTM C 309, Type 2, Class B and ACI 302 specifications. The application rate shall be at 200 square feet per gallon of curing agent unless a greater rate of coverage is specified by the manufacturer. The curing compound shall be W.R. Meadows 1200-White-Concrete Curing Compound or approved equal.

The placement of bituminous pavement adjacent to concrete curbs, gutters, or alley intersections shall not be permitted until the newly placed concrete has reached eighty percent (80%) of the mix design twenty-eight (28) day design strength.

312.04 Basis of Payment. Refer to Bid Item Clarification.

333 LANDSCAPING

333.03 Site Preparation Elevation differences from existing back of sidewalk and landscaping will occur. The contractor will be required to repair this area to the satisfaction of the city and property owner. Elevations may vary however the maximum it will vary is +/- .15 of a foot. Turf patches will be a

minimum of 18” wide. Maintenance of the new sod shall be the responsibility of the homeowner. Special care should be noted where sprinkler system are in place, damage and adjustment of these areas will be required.

333.18 Basis of Payment. There shall be NO DIRECT PAYMENT for modifying the existing landscaping and adjustment to the existing irrigation system. Compensation shall be deemed included in other items of work.

335 CLEANUP

335.01 Description. This work shall consist of furnishing all materials, equipment, and labor for the cleanup of construction areas as specified and/or as directed by the City Project Coordinator. In addition, all requirements of the Washoe County District Health Department for the Dust Control Permit and NDEP’s Stormwater Pollution Prevention Plan shall be complied with at all times during the work.

349 TRAFFIC CONTROL

349.01 Description. This work shall consist of furnishing all materials, equipment and labor to maintain proper traffic routing, parking control, access to all residences and businesses, and public safety for the duration of the project. All construction traffic control plans shall conform to the latest editions of either the NDOT Work Zone Traffic Control Handbook or Part VI of the MUTCD. All signs and barricades shall conform to Section 332 of the Standard Specifications, these Special Provisions, Construction Plans, Part VI of the MUTCD, and/or said Handbook, where applicable.

Flag persons shall be used during working hours to control traffic flows in accordance with the NDOT Work Zone Traffic Control Handbook and as directed by the City Project Coordinator.

Traffic control signs shall include the names of the streets involved for detour or closure.

“Road Construction Ahead” signs shall be replaced with the Road Work Ahead sign (W20-1). No “Road Construction Ahead” signs shall be allowed on the project.

All streets shall be open for normal traffic movement during nighttime and weekend periods, unless previously approved by the City Engineer. The closure of any two adjacent parallel streets at the same time is prohibited. A street will be considered closed to through traffic if it is barricaded, or a closed sign is posted on any portion of the street, including intersections of crossing streets.

The storage of construction materials within the public streets and alleys during nighttime and weekend periods is prohibited.

A minimum of two (2) working days written notification shall be given to adjacent residents, businesses, Police and Fire Departments, paramedic/ambulance services, Waste Management, and the City Project Coordinator, of planned street closures and when parking restrictions are required. Where work is being performed along Citifare bus routes, the Regional Transportation Commission shall also be notified in similar fashion. Such notification shall be made separately for each work site and shall be made each time work commences at that site when operations are intermittent. This notification shall state the date work will commence and the hours and days to be worked. When construction will necessitate traffic control affecting access to any hospital, forty-eight (48) hours notification and coordination will be given in person mutually by the Contractor and the City Project Coordinator.

The Police Department will not enforce parking restrictions indiscriminately applied. A "No Parking" notification, supplied by the contractor, shall be applied only as and when needed, and shall be removed unless absolutely necessary.

The Contractor shall submit a Project Work Schedule and a detailed Traffic Control plan to the City Project Coordinator five (5) working days prior to the pre-construction conference. Prior to the start of construction, the Contractor must have a Traffic Control plan approved by the City Project Coordinator.

Any signs, barricades, or barriers which are necessary for nighttime hours or poor visibility shall utilize warning lights as specified in the latest editions of either the NDOT Work Zone Traffic Control Handbook or Part VI of the MUTCD.

The Contractor shall coordinate Traffic Control with the Sparks Police Department with respect to any special events that may be affected by construction activities.

The Contractor shall notify Sparks Dispatch ((775) 353-2231) 24 hours prior to any scheduled detour.

The Contractor shall be responsible for Traffic Control until such time as any street markings eradicated by the work are replaced with permanent markings. The Contractor shall be required to provide and install any temporary pavement markings as required and these shall conform to spacing and other requirements as established by the City.

The approval by the City Project Coordinator of the submitted Traffic Control Plan shall in no way relieve the Contractor of his responsibility for safety requirements conforming to Section 22 of the Special Provisions. Failure to comply with any specification herein or with direction from the City Project Coordinator may result in a stoppage of work until compliance is restored.

349.04 Measurement of Quantities and Basis of Payment. There shall be NO DIRECT PAYMENT for Traffic Control. Compensation shall be deemed included in other items of work.

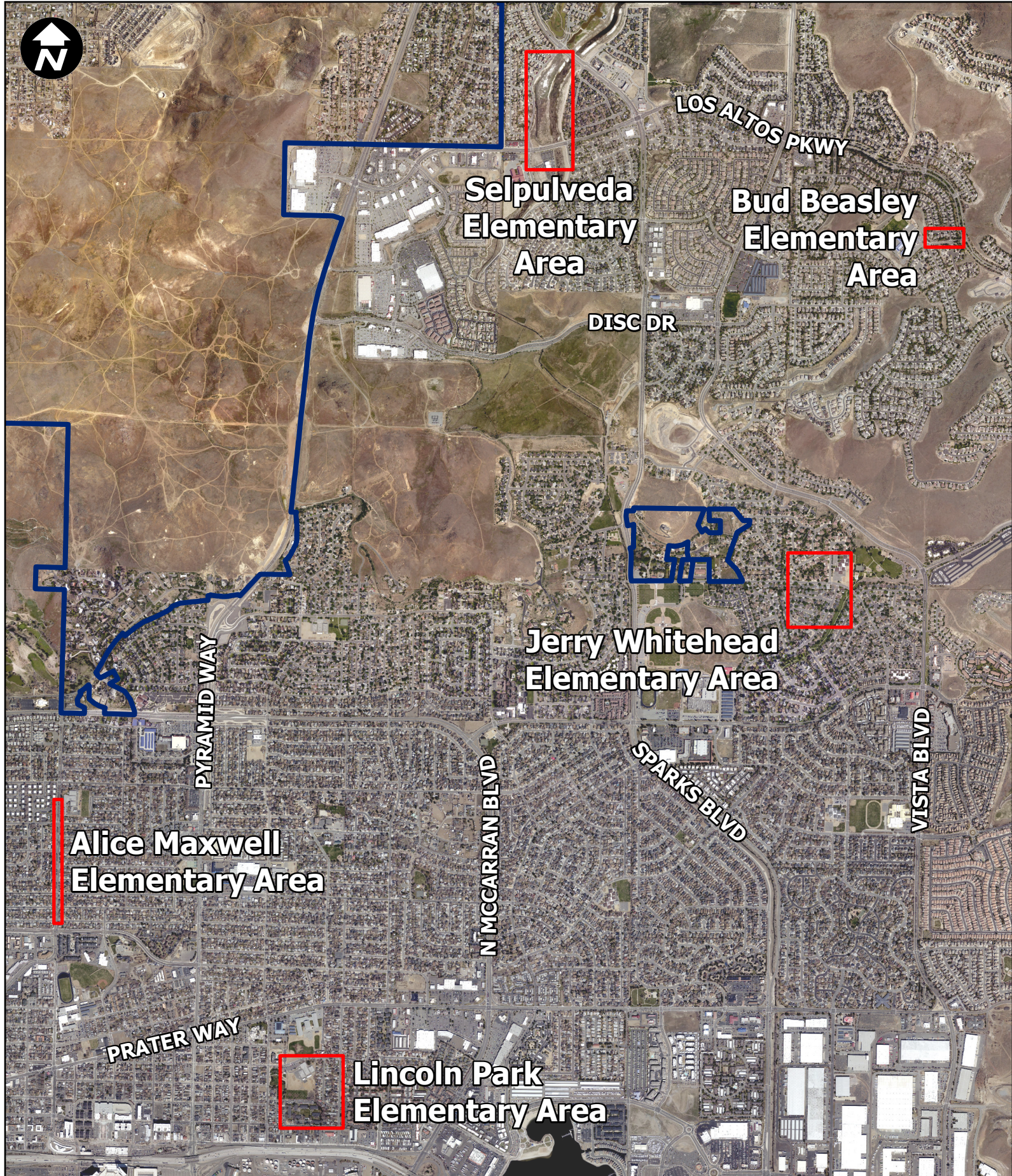



City of Sparks
Pedestrian Replacement Project – Phase 1

School: Alice Maxwell Elementary
 Intersection: Rock Blvd and Prospect Ave
 5/21/2024

 Project Pedestrian Ramp  Parcels

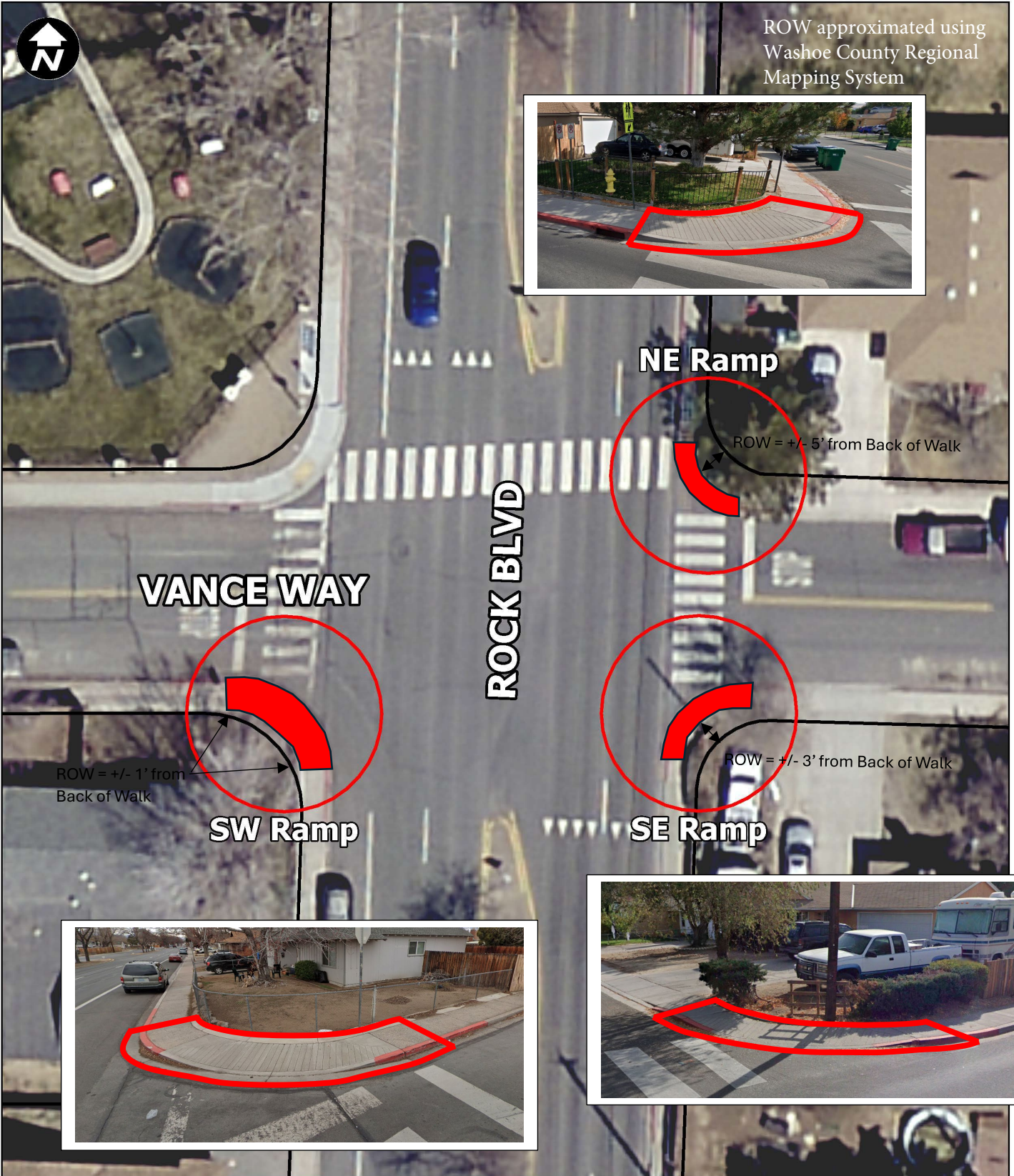

City of Sparks
Pedestrian Replacement Project – Phase 1

School: Alice Maxwell Elementary
Intersection: Rock Blvd and Vance Way
5/21/2024

○ Project Pedestrian Ramp □ Parcels

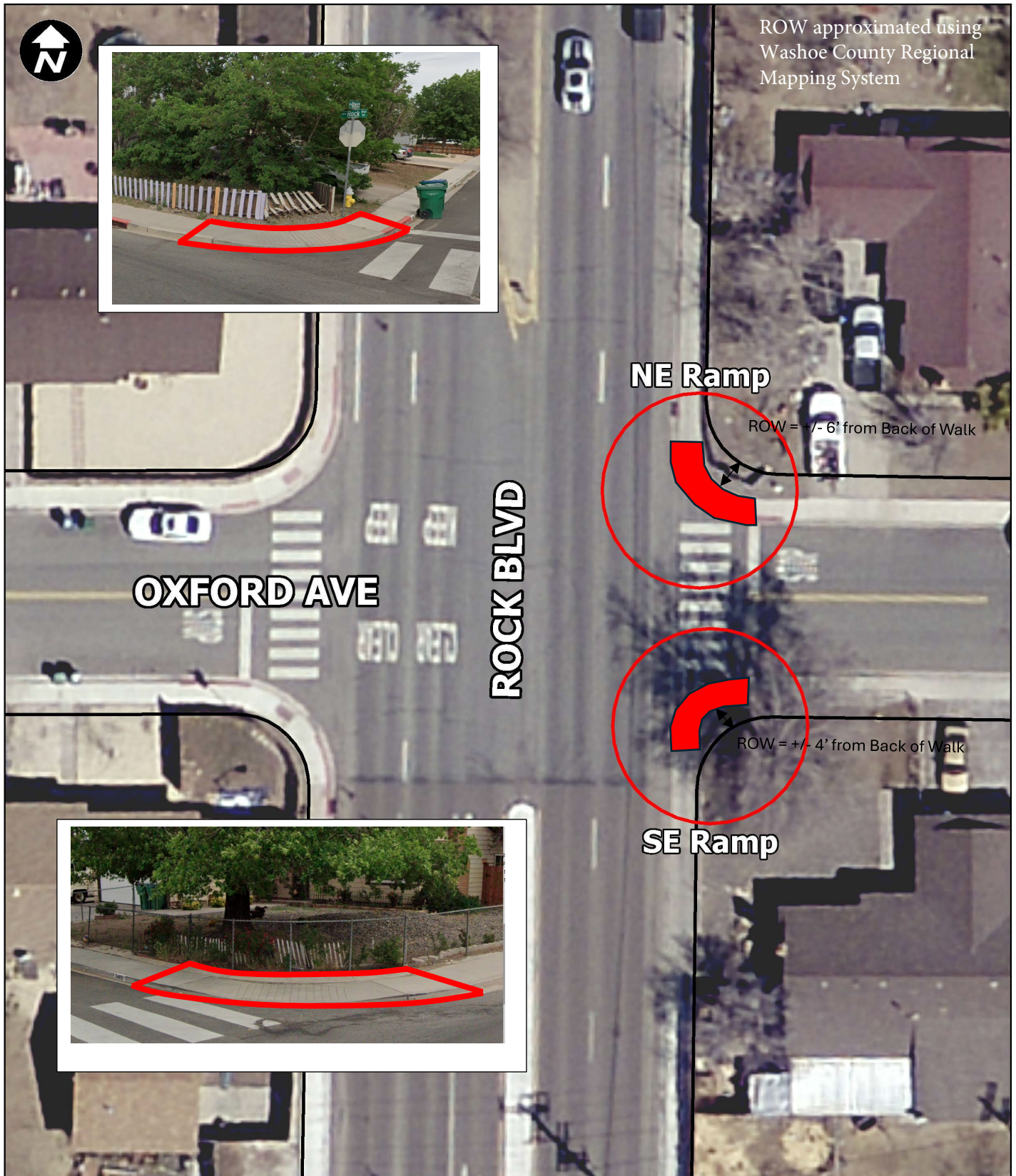

City of Sparks
Pedestrian Replacement Project – Phase 1

School: Alice Maxwell Elementary
 Intersection: Rock Blvd and Oxford Ave
 5/21/2024

○ Project Pedestrian Ramp □ Parcels



ROW approximated using Washoe County Regional Mapping System

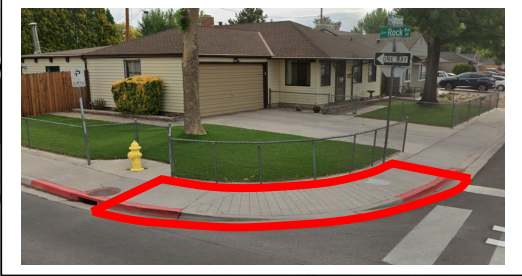

NE Ramp

ROW = +/- 2' from Back of Walk

ROCK BLVD

UPTON WAY



ROW = +/- 2' from Back of Walk

SE Ramp



City of Sparks Pedestrian Replacement Project – Phase 1

School: Alice Maxwell Elementary
Intersection: Rock Blvd and Upton Way
5/21/2024

Project Pedestrian Ramp Parcels

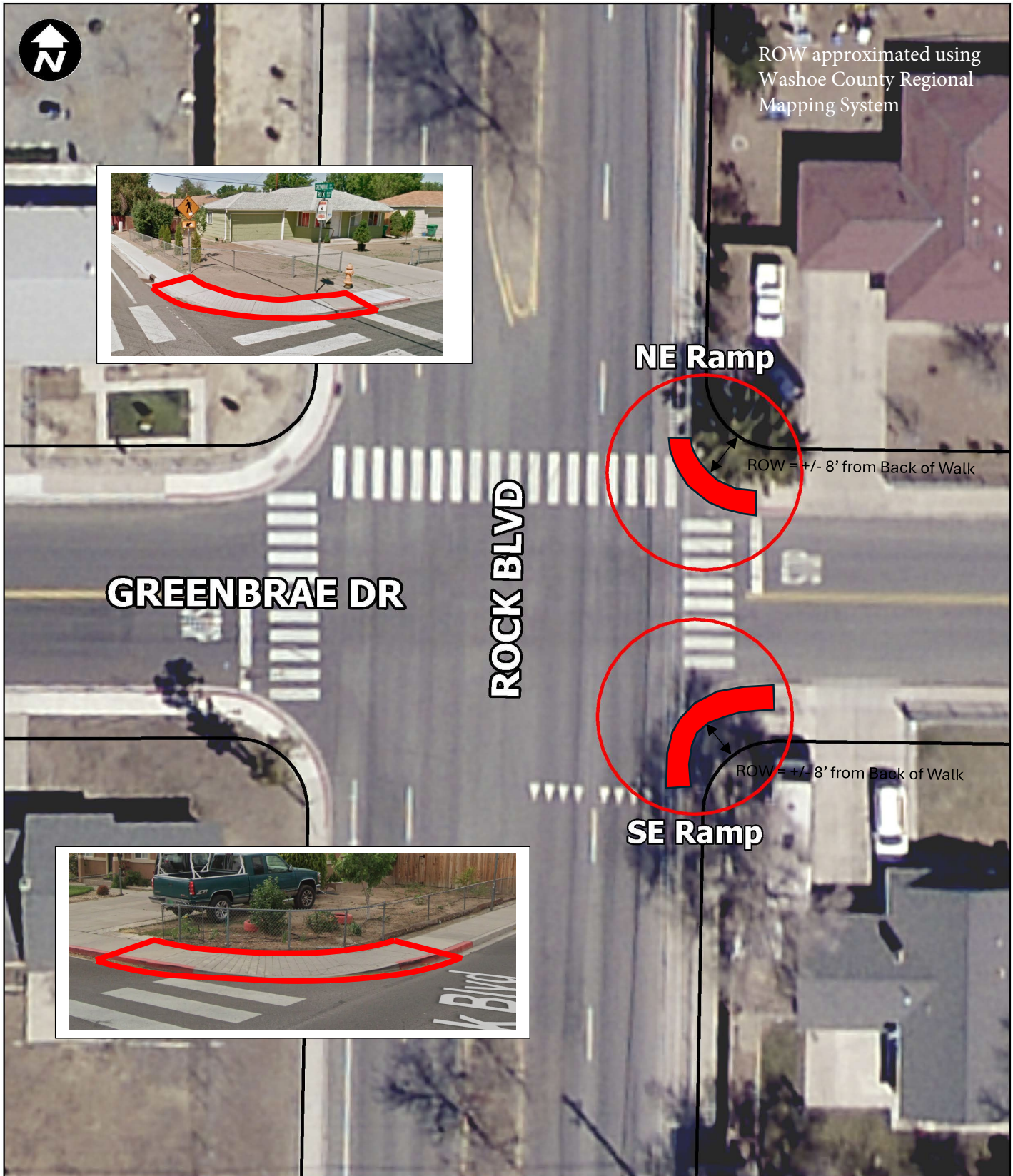

ROW approximated using Washoe County Regional Mapping System

NE Ramp

ROW = +/- 8' from Back of Walk

SE Ramp

ROW = +/- 8' from Back of Walk

GREENBRAE DR

ROCK BLVD



City of Sparks
Pedestrian Replacement Project – Phase 1

School: Alice Maxwell Elementary
 Intersection: Rock Blvd and Greenbrae Dr
 5/21/2024

○ Project Pedestrian Ramp □ Parcels



ROW approximated using Washoe County Regional Mapping System



NW Ramp

NE Ramp

ROW = +/- 3' from Back of Walk

ROW = +/- 3' from Back of Walk

TYLER WAY

ROCK BLVD

ROW = +/- 3' from Back of Walk

ROW = +/- 3' from Back of Walk

SW Ramp

SE Ramp

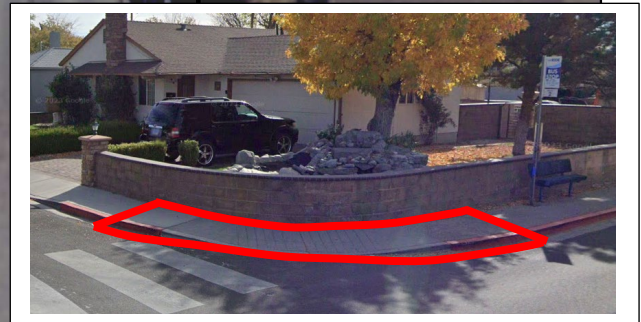
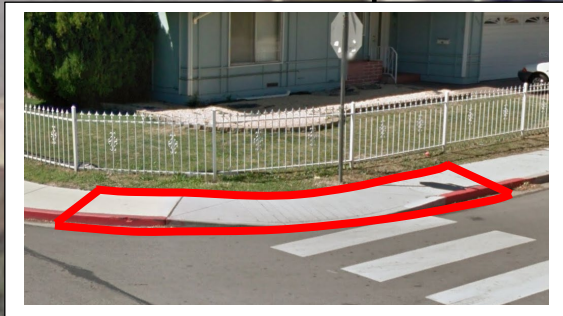

City of Sparks
Pedestrian Replacement Project – Phase 1

School: Alice Maxwell Elementary
Intersection: Rock Blvd and Tyler Way
5/21/2024

 Project Pedestrian Ramp  Parcels

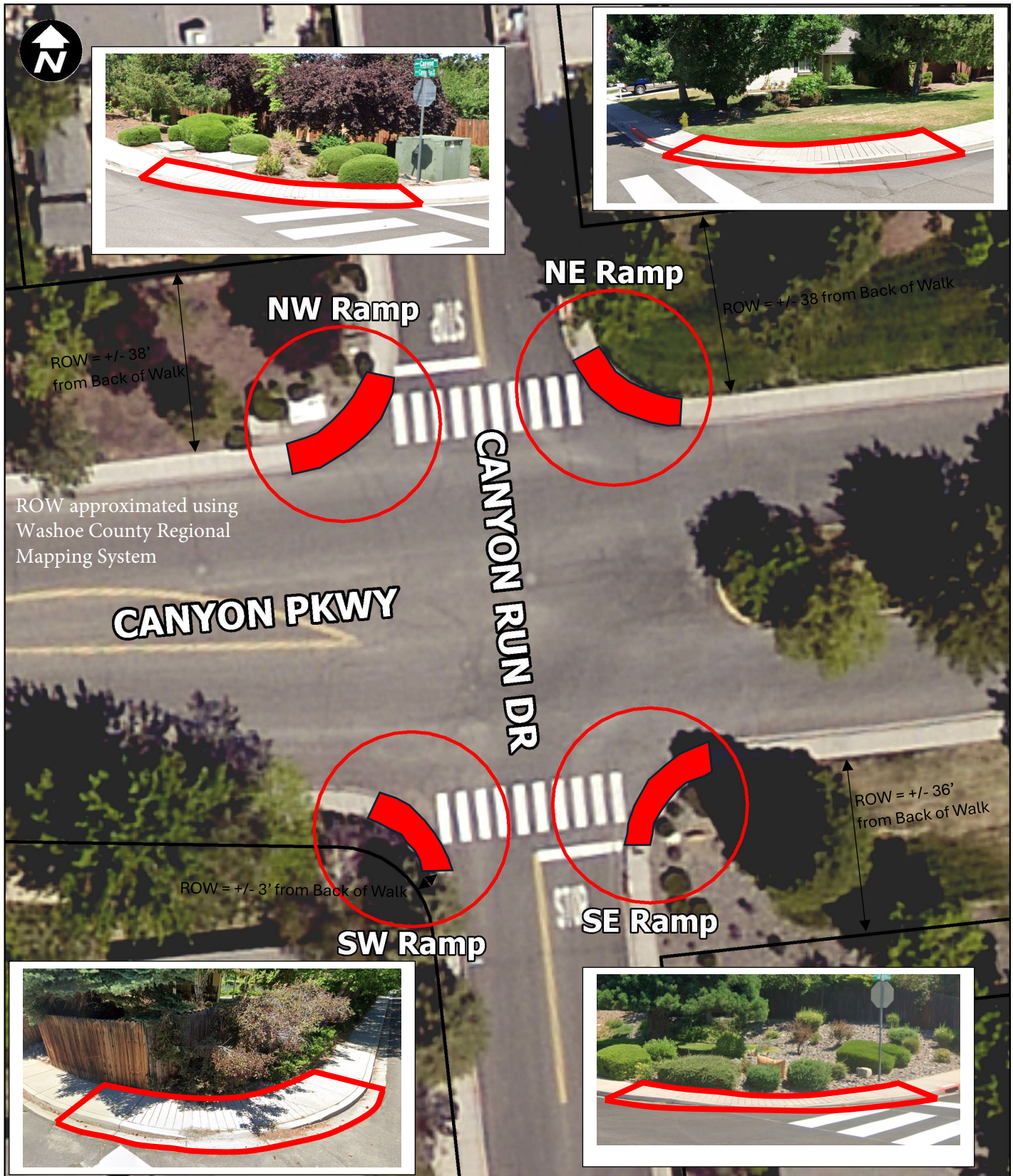

City of Sparks
Pedestrian Replacement Project – Phase 1

School: Bud Beasley Elementary
 Intersection: Canyon Pkwy and Canyon Run Dr
 5/21/2024

○ Project Pedestrian Ramp □ Parcels



ROW approximated using Washoe County Regional Mapping System

LOS ALTOS PKWY

CANYON PKWY

SW Ramp

ROW = +/- 53" from Back of Walk



City of Sparks Pedestrian Replacement Project – Phase 1

School: Bud Beasley Elementary
Intersection: Los Altos Pkwy and Canyon Pkwy
5/21/2024

Project Pedestrian Ramp Parcels

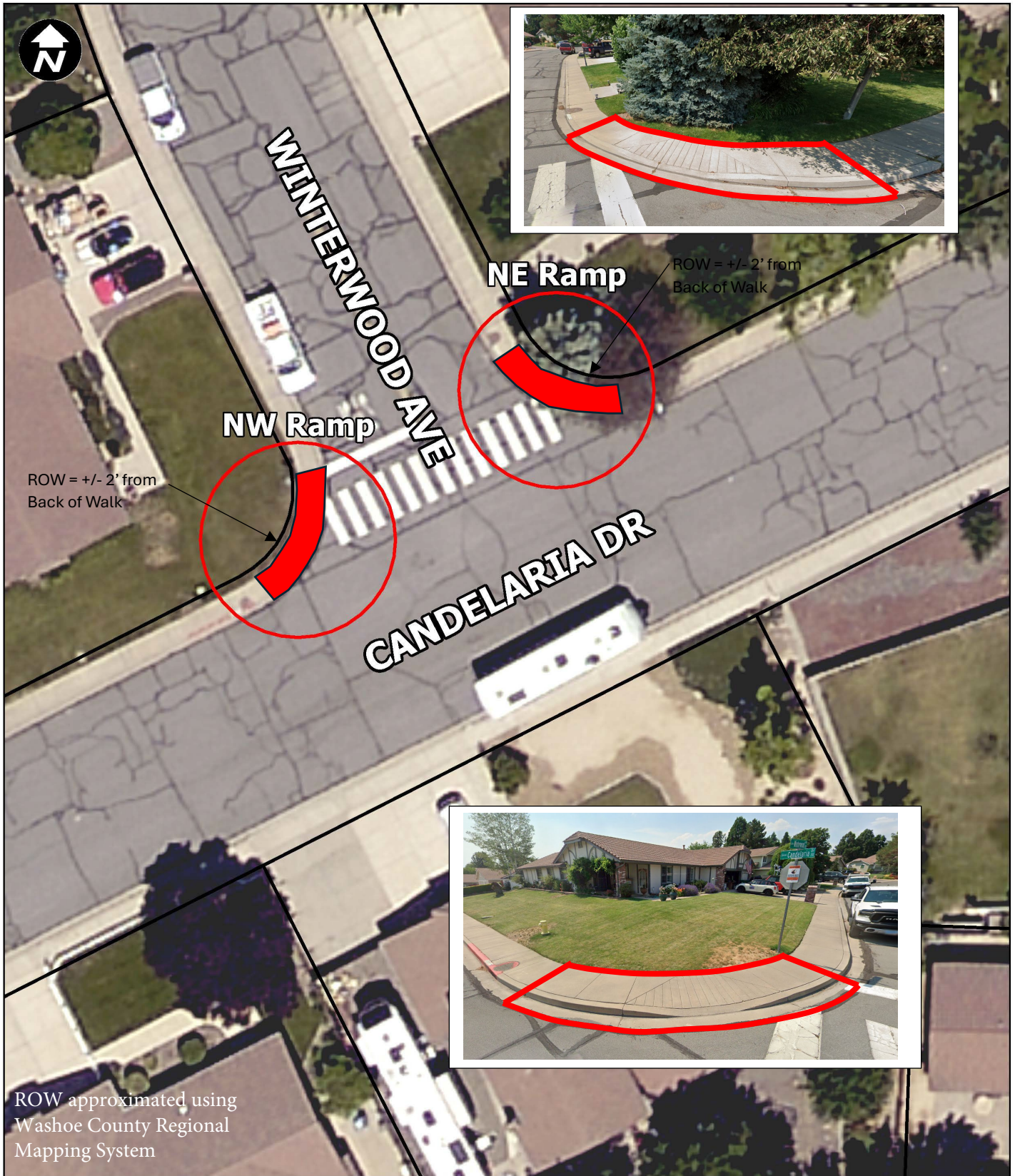

City of Sparks
Pedestrian Replacement Project – Phase 1

School: Jerry Whitehead Elementary
 Intersection: Candelaria Dr and Winterwood Ave
 5/21/2024

○ Project Pedestrian Ramp □ Parcels



City of Sparks
Pedestrian Replacement Project – Phase 1

School: Jerry Whitehead Elementary
 Intersection: Candelaria Dr and Black Forest Ln
 5/21/2024

○ Project Pedestrian Ramp □ Parcels



City of Sparks
Pedestrian Replacement Project – Phase 1

School: Jerry Whitehead Elementary
 Intersection: Candelaria Dr and Sprucemont St
 5/21/2024

○ Project Pedestrian Ramp □ Parcels



City of Sparks
Pedestrian Replacement Project – Phase 1

School: Jerry Whitehead Elementary
 Intersection: Candelaria Dr and Hamilton Dr
 5/21/2024

○ Project Pedestrian Ramp □ Parcels



ROW approximated using Washoe County Regional Mapping System

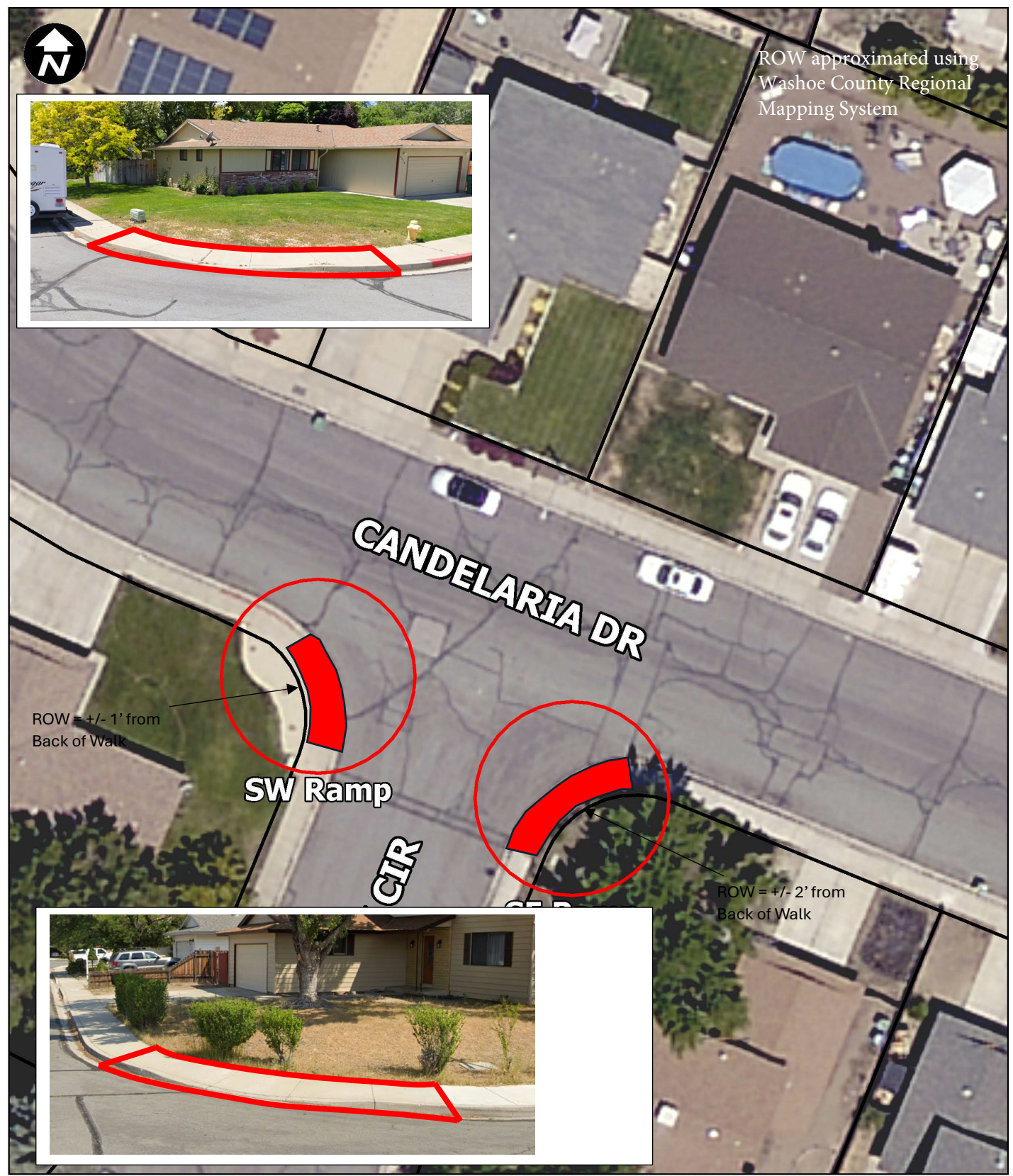
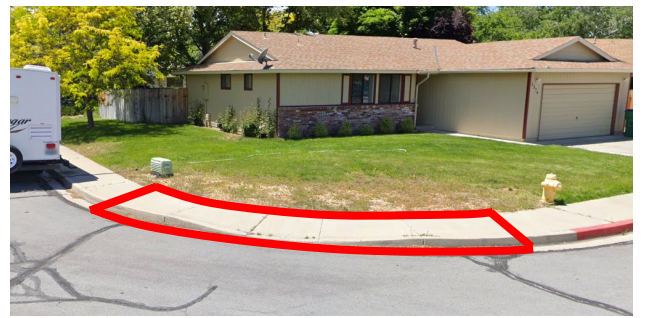

City of Sparks
Pedestrian Replacement Project – Phase 1
School: Jerry Whitehead Elementary
Intersection: Candalaria Dr and Betty Cir
5/21/2024

 Project Pedestrian Ramp  Parcels



ROW approximated using Washoe County Regional Mapping System

Whitehead Elementary

Pah Rah Mountain Park

ROW = +/- 5' from Back of Walk

N Ramp

SHADOW LN

Greenbelt

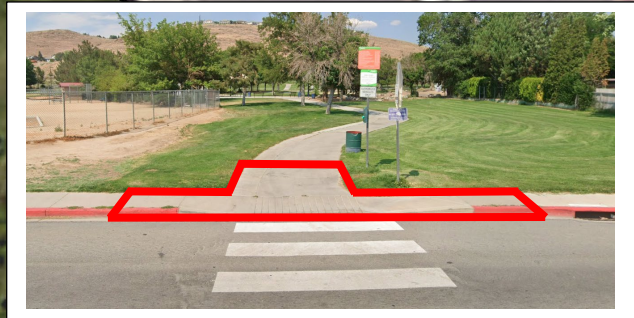

**City of Sparks
Pedestrian Replacement Project – Phase 1**

School: Jerry Whitehead Elementary
Intersection: Shadow Ln and Park Entrance
5/21/2024

 Project Pedestrian Ramp  Parcels



ROW approximated using Washoe County Regional M&T System



NW Ramp

ROW = +/- 10' from Back of Walk



LINCOLN WAY

STANFORD WAY

E LINCOLN WAY

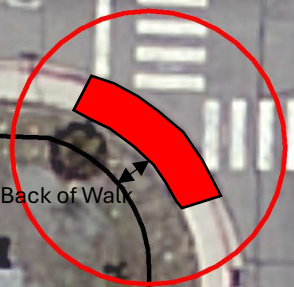

ROW = +/- 6' from Back of Walk

SW Ramp



City of Sparks Pedestrian Replacement Project – Phase 1

School: Lincoln Park Elementary
Intersection: Stanford Way and Lincoln Way
5/21/2024

 Project Pedestrian Ramp  Parcels

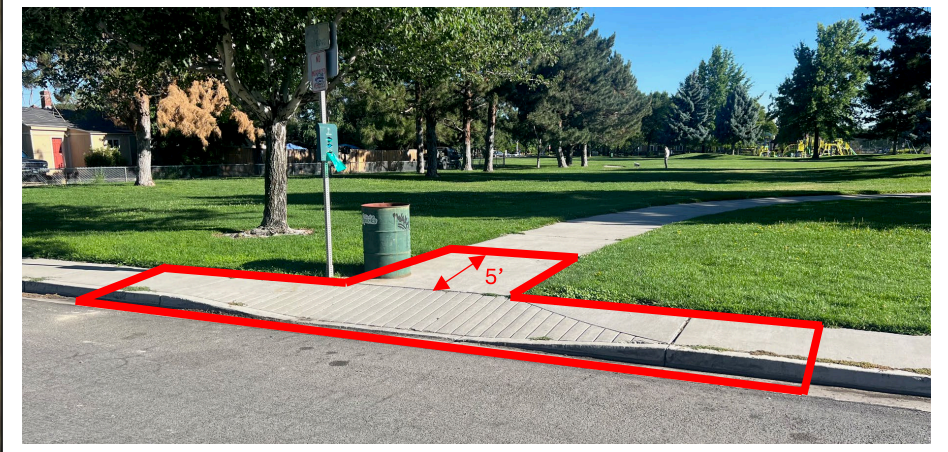

N Ramp

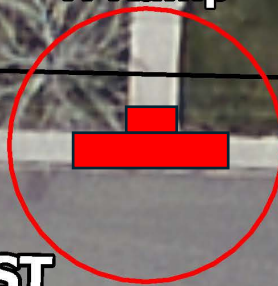

ROW = +/- 11' from Back of Walk

D ST

ROW = +/- 5' from Back of Walk



SW Ramp

3RD ST



ROW approximated using Washoe County Regional Mapping System



City of Sparks Pedestrian Replacement Project – Phase 1

School: Lincoln Park Elementary
Intersection: 3rd St and D St
5/21/2024

 Project Pedestrian Ramp  Parcels

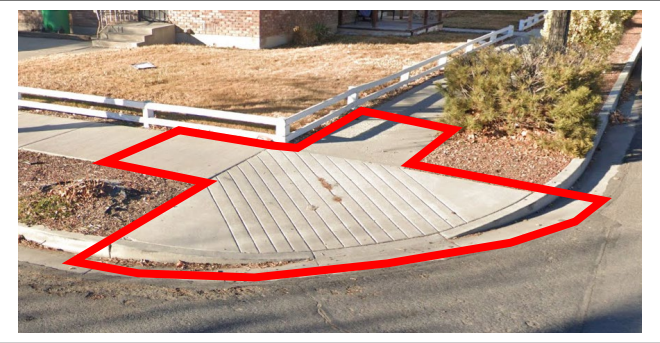

City of Sparks
Pedestrian Replacement Project – Phase 1

School: Lincoln Park Elementary
Intersection: 3rd St and C St
7/10/2024

 Project Pedestrian Ramp  Parcels



ROW approximated using Washoe County Regional Mapping System



City of Sparks Pedestrian Replacement Project – Phase 1

School: Lincoln Park Elementary
Intersection: Lincoln Way and Fodrin Way
5/21/2024

 Project Pedestrian Ramp  Parcels

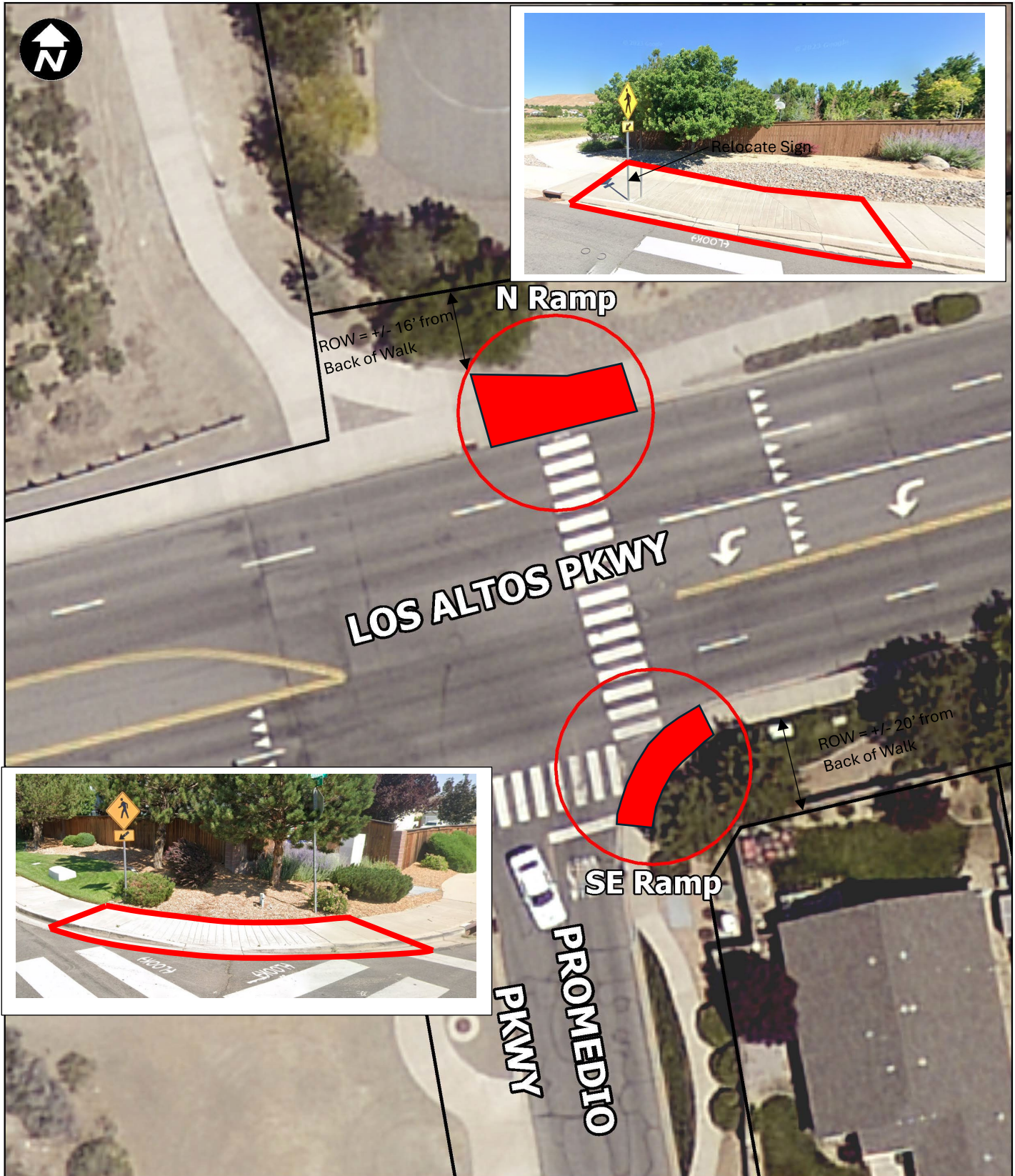

City of Sparks
Pedestrian Replacement Project – Phase 1

School: Selpulveda Elementary
 Intersection: Los Altos Pkwy and Promedio Pkwy
 5/21/2024

○ Project Pedestrian Ramp □ Parcels



City of Sparks
Pedestrian Replacement Project – Phase 1

School: Selpulveda Elementary
 Intersection: Promedio Ct and Promedio Pkwy
 5/21/2024

○ Project Pedestrian Ramp □ Parcels



ROW approximated using Washoe County Regional Mapping System



NE Ramp

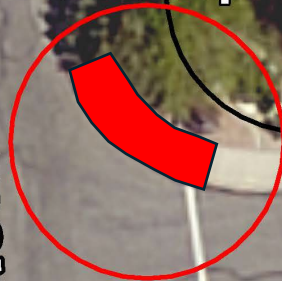

ROW = +/- 2' from Back of Walk

PROMEDIO PKWY

MONTERO DR



ROW = +/- 2' from Back of Walk

SE Ramp

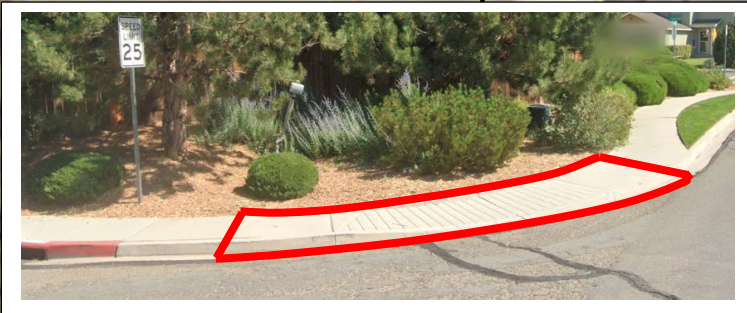

City of Sparks Pedestrian Replacement Project – Phase 1

School: Selpulveda Elementary
Intersection: Montero Dr and Promedio Pkwy
5/21/2024

Project Pedestrian Ramp Parcels



City of Sparks
Pedestrian Replacement Project – Phase 1

School: Selpulveda Elementary
 Intersection: Ion Dr and Baxter Pass Ct
 5/21/2024

○ Project Pedestrian Ramp □ Parcels



City of Sparks
Pedestrian Replacement Project – Phase 1

School: Selpulveda Elementary
 Intersection: Ion Dr and Vidette Meadows Dr
 5/21/2024

○ Project Pedestrian Ramp □ Parcels

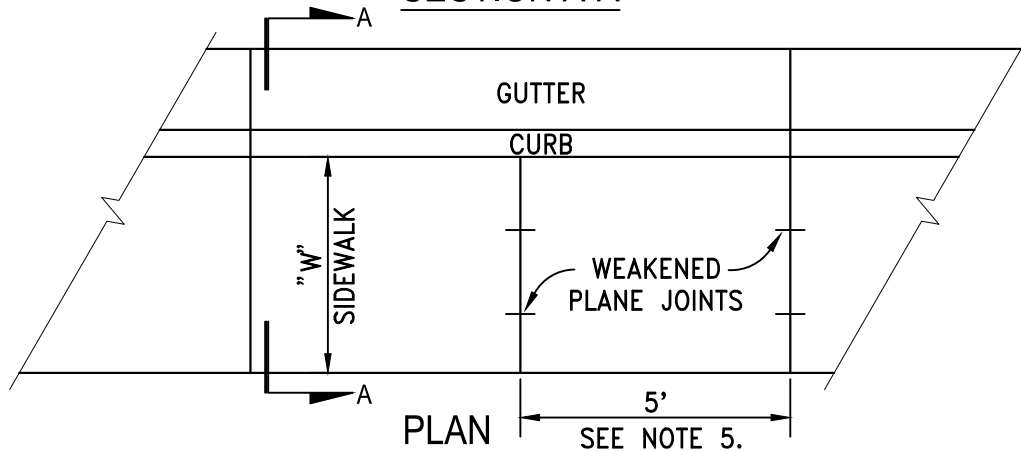
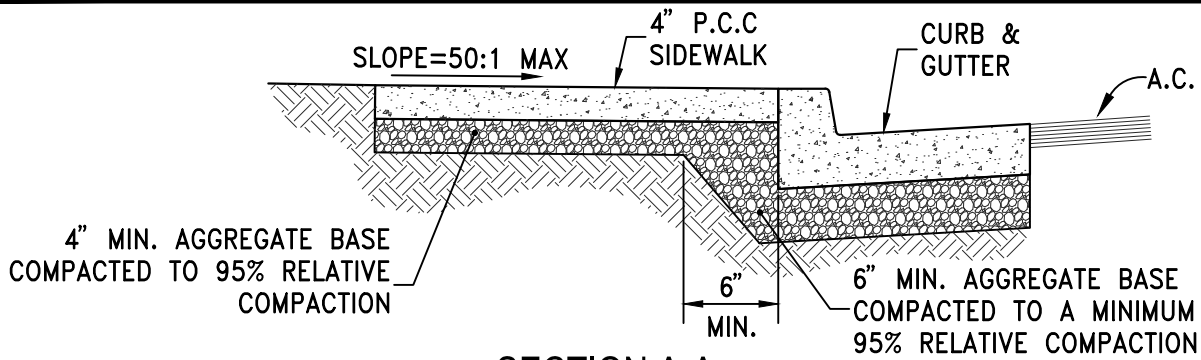

NOTES:

1. PORTLAND CEMENT CONCRETE (P.C.C.) SHALL HAVE THE FOLLOWING CHARACTERISTICS: 4000 PSI MIN. COMPRESSIVE STRENGTH AT 28 DAYS, MIN. 6 SACKS OF CEMENT PER CUBIC YARD WITH MAX. WATER-CEMENT RATIO OF 0.45, AIR ENTRAINMENT 6% ±1.5%, SLUMP AT 1 TO 4 INCHES. MIX DESIGN SHALL CONFORM TO THE REQUIREMENTS OF SECTION 337 OF STANDARD SPECIFICATIONS OF PUBLIC WORKS CONSTRUCTION (SSPWC), AS ADOPTED BY CITY COUNCIL. CEMENT SHALL BE TYPE II. ALL CEMENT CONCRETE SHALL HAVE A COARSE AGGREGATE GRADATION CONFORMING TO SIZE No. 67. POLYPROPYLENE OR CELLULOSE FIBERS SHALL BE ADDED TO THE P.C.C. AT 1.5 LBS. PER CUBIC YARD. ALL MATERIALS SHALL CONFORM TO SSPWC, AS ADOPTED BY CITY COUNCIL.
2. AGGREGATE BASE MATERIAL UNDER SIDEWALKS SHALL BE TYPE 2, CLASS B CRUSHED AGGREGATE BASE. MATERIALS SHALL CONFORM TO SSPWC SECTION 200, AS ADOPTED BY CITY COUNCIL.
3. SIDEWALK WIDTH "W" SHALL BE 4 FT MIN. WITH 60" PASSING SPACE EVERY 200' ON RESIDENTIAL STREETS AND 6 FT MIN. ON COLLECTOR AND ARTERIAL STREETS.
4. WEAKENED PLANE JOINTS SHALL BE CONSTRUCTED AT 5 FT INTERVALS AND ACCORDANCE WITH SECTION 312 OF THE SSPWC, AS ADOPTED BY CITY COUNCIL.
5. ALL ADJACENT CONCRETE REMOVAL SHALL BE TO NEAT SAW CUT LINES AT RIGHT ANGLES TO NEW SIDEWALK. DOWEL INTO EXISTING ADJACENT CONCRETE SIDEWALK WITH A MINIMUM OF TWO (2) No. 4 REINFORCEMENT BARS EQUALLY SPACED ACROSS WIDTH "W". DOWELS SHALL PENETRATE A MINIMUM OF 4" INTO EXISTING CONCRETE.
6. SIDEWALKS SHALL NOT BE POURED MONOLITHICALLY WITH CURBS.
7. TUNNELING AND/OR BORING IS NOT ALLOWED.

STANDARD DETAILS FOR PUBLIC WORKS CONSTRUCTION		DRAWING No.
	SIDEWALK DETAIL	S-103
		APPROVED BY: JE DATE: 1/2020

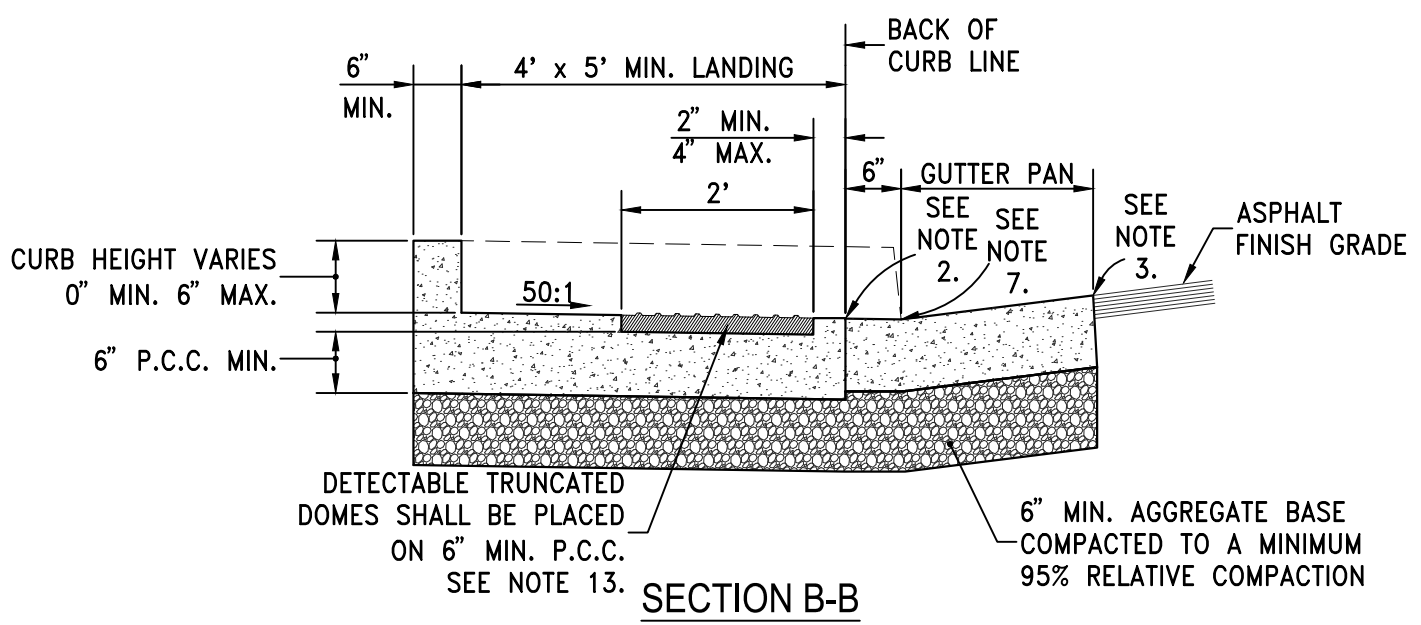
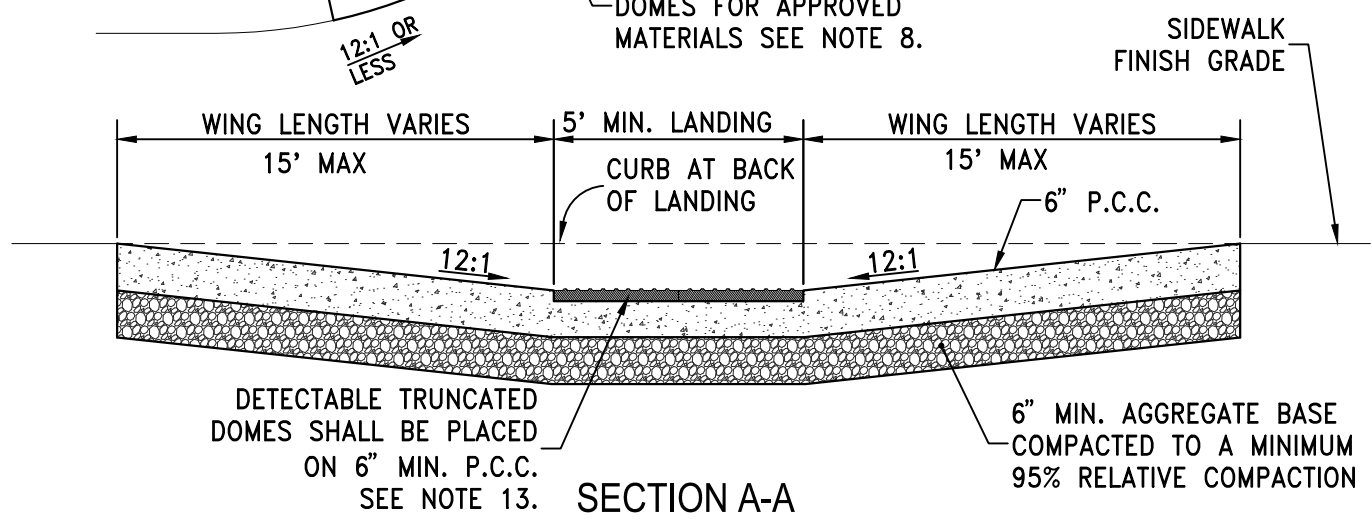
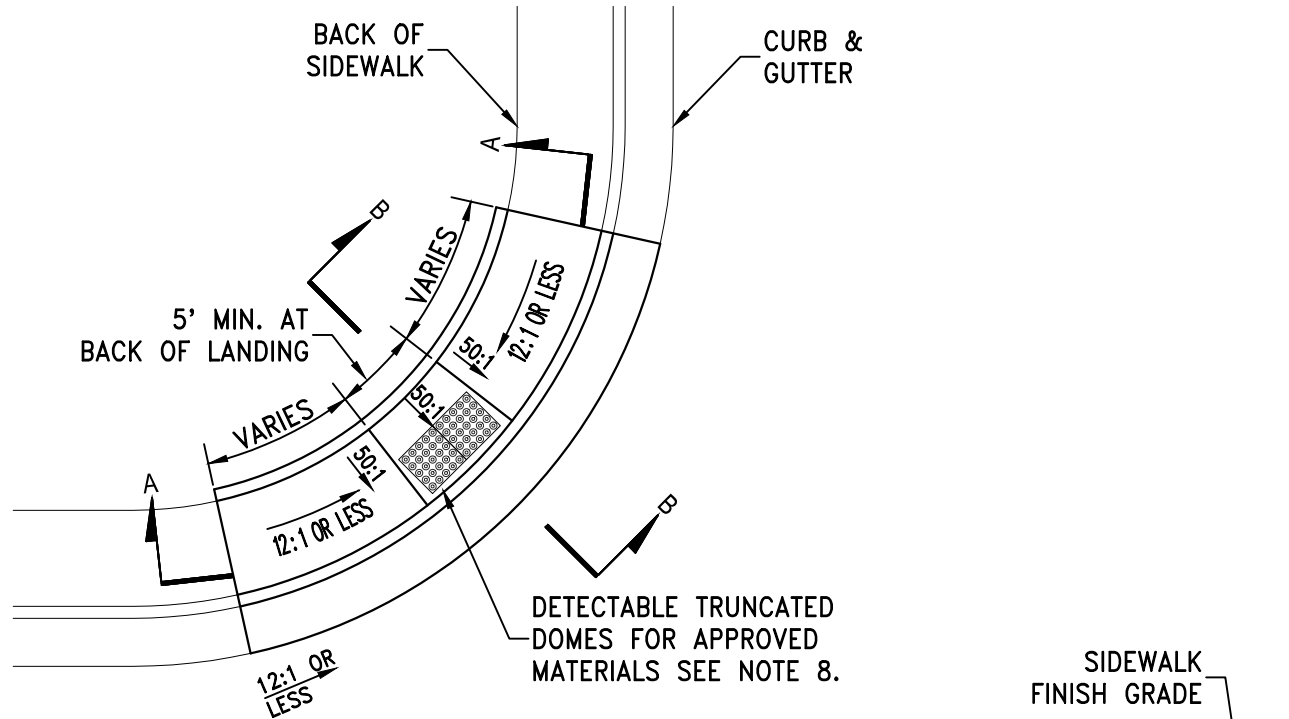

STANDARD DETAILS FOR PUBLIC WORKS CONSTRUCTION		DRAWING No.
	PEDESTRIAN RAMP - EXISTING SIDEWALKS	S-106A
		APPROVED BY: JE DATE: 1/2020

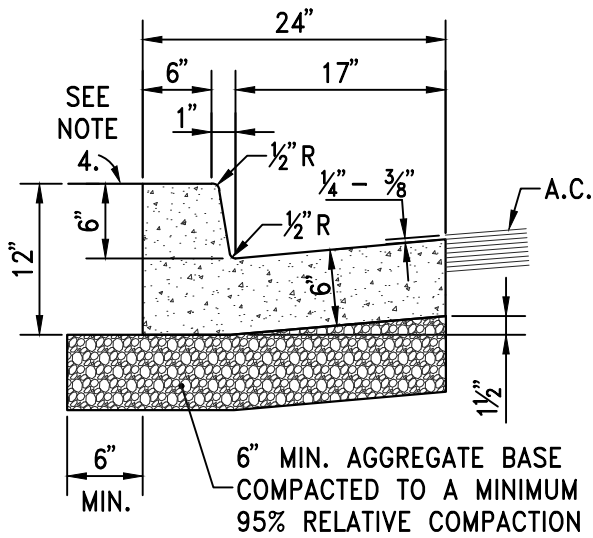

TYPE 1

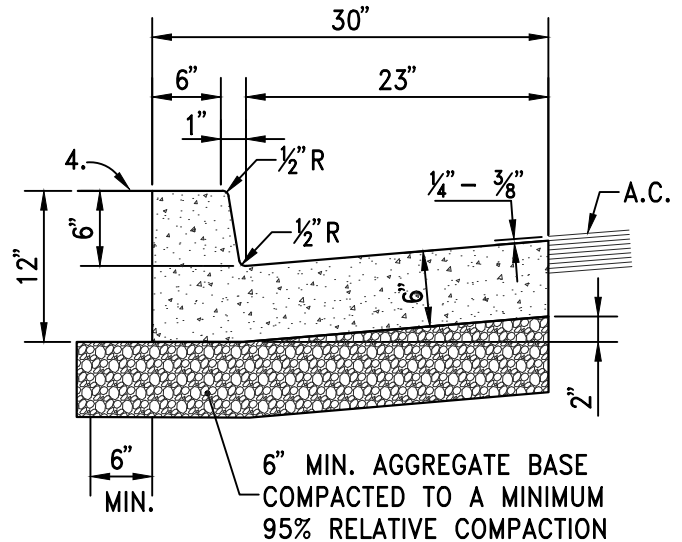

TYPE 1A

NOTES:

1. PORTLAND CEMENT CONCRETE (P.C.C.) SHALL HAVE THE FOLLOWING CHARACTERISTICS: 4000 PSI MIN. COMPRESSIVE STRENGTH AT 28 DAYS, MIN. 6 SACKS OF CEMENT PER CUBIC YARD WITH MAX. WATER-CEMENT RATIO OF 0.45, AIR ENTRAINMENT 6% ±1.5%, SLUMP AT 1 TO 4 INCHES. MIX DESIGN SHALL CONFORM TO THE REQUIREMENTS OF SECTION 337 OF STANDARD SPECIFICATIONS OF PUBLIC WORKS CONSTRUCTION (SSPWC), AS ADOPTED BY CITY COUNCIL. CEMENT SHALL BE TYPE II. ALL CEMENT CONCRETE SHALL HAVE A COARSE AGGREGATE GRADATION CONFORMING TO SIZE No. 67. POLYPROPYLENE OR CELLULOSE FIBERS SHALL BE ADDED TO THE P.C.C. AT 1.5 LBS. PER CUBIC YARD. ALL MATERIALS SHALL CONFORM TO SSPWC, AS ADOPTED BY CITY COUNCIL.
2. AGGREGATE BASE MATERIAL UNDER AND BEHIND CURB AND GUTTER SHALL BE TYPE 2, CLASS B CRUSHED AGGREGATE BASE. MATERIALS SHALL CONFORM TO SSPWC SECTION 200, AS ADOPTED BY CITY COUNCIL.
3. WEAKENED PLANE JOINTS SHALL BE EVERY 10 FEET AND LOCATED ON THE BACK, TOP AND FACE OF THE CURB AND THE TOP OF THE GUTTER PAN.
4. CURB & GUTTER SECTIONS SHALL BE PLACED SEPARATELY FROM SIDEWALK SECTIONS. WHEN SIDEWALK IS NOT REQUIRED DIRECTLY BEHIND THE CURB, BACKFILL TO TOP OF CURB FOR A HORIZONTAL DISTANCE OF 12" FROM BACK FACE OF CURB AND COMPACT TO 90% RELATIVE COMPACTION.
5. FOR REPLACEMENT OF EXISTING CURB AND GUTTER, MATCH EXISTING TYPE.

STANDARD DETAILS FOR PUBLIC WORKS CONSTRUCTION

DRAWING No.



P.C.C.
CURB & GUTTER

S-109

APPROVED BY: JE DATE: 1/2020

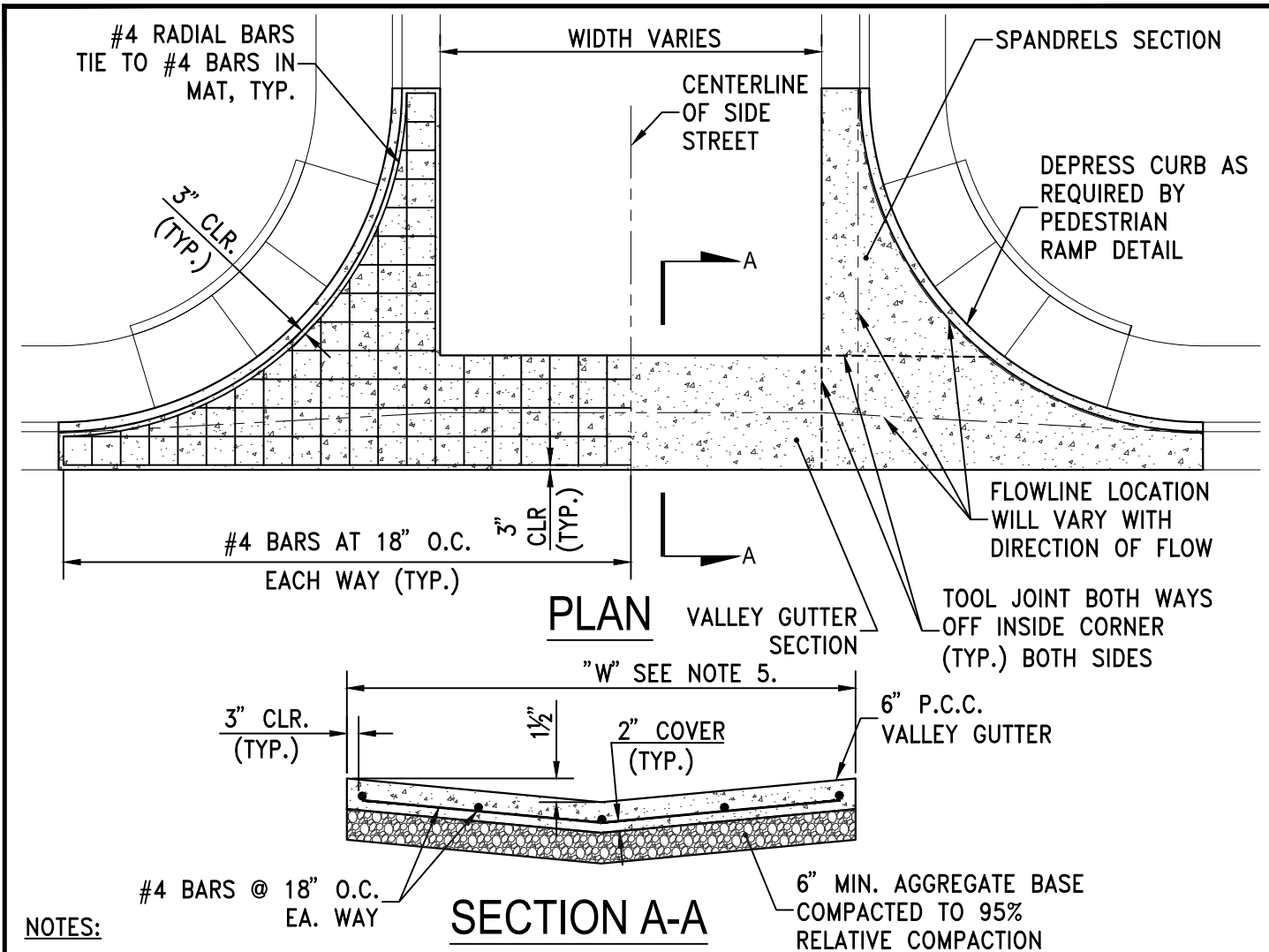

NOTES:

1. PORTLAND CEMENT CONCRETE (P.C.C.) SHALL HAVE THE FOLLOWING CHARACTERISTICS: 4000 PSI MIN. COMPRESSIVE STRENGTH AT 28 DAYS, MIN. 6 SACKS OF CEMENT PER CUBIC YARD WITH MAX. WATER-CEMENT RATIO OF 0.45, AIR ENTRAINMENT 6% ±1.5%, SLUMP AT 1 TO 4 INCHES. MIX DESIGN SHALL CONFORM TO THE REQUIREMENTS OF SECTION 337 OF STANDARD SPECIFICATIONS OF PUBLIC WORKS CONSTRUCTION (SSPWC), AS ADOPTED BY CITY COUNCIL. CEMENT SHALL BE TYPE II. ALL CEMENT CONCRETE SHALL HAVE A COARSE AGGREGATE GRADATION CONFORMING TO SIZE No. 67. POLYPROPYLENE OR CELLULOSE FIBERS SHALL BE ADDED TO THE P.C.C. AT 1.5 LBS. PER CUBIC YARD. ALL MATERIALS SHALL CONFORM TO SSPWC, AS ADOPTED BY CITY COUNCIL
2. AGGREGATE BASE UNDER VALLEY GUTTER AND SPANDRELS SHALL BE TYPE 2, CLASS B CRUSHED AGGREGATE. ALL MATERIALS SHALL CONFORM TO SSPWC SECTION 200, AS ADOPTED BY CITY COUNCIL.
3. P.C.C VALLEY GUTTER DETAIL FOR RESIDENTIAL OR COMMERCIAL ZONES ONLY FOR OTHER APPLICATIONS AN ENGINEERED DESIGN IS REQUIRED.
4. VALLEY GUTTER SHALL HAVE WEAKENED PLANE JOINTS EVERY 10 FEET.
5. LOCAL AND COLLECTOR STREETS, "W"=6' MIN. ARTERIAL STREETS (DRIVEWAYS ONLY), "W"=10' MIN.
6. VALLEY GUTTER SECTIONS (SPANDRELS) ALONG CURB & GUTTER MAY BE A MONOLITHIC POUR AS SHOWN. DOWELS MATCHING REBAR SPACING SHOWN ARE REQUIRED FROM VALLEY GUTTER SECTION TO SPANDREL SECTION IF POURED SEPARATELY.

STANDARD DETAILS FOR PUBLIC WORKS CONSTRUCTION	DRAWING No.
P.C.C. VALLEY GUTTER	S-107
	APPROVED BY: JE DATE: 1/2020

Special Conditions and Forms Specific to Federal Requirements (if applicable)

In instances where these Special Conditions conflict with the General Conditions, the Special Conditions will prevail with respect to that instance or item(s).

The City of Sparks has recognized and adopts the “Procurement Standards” generally referred to as “Uniform Guidance” detailed in 2 CFR Part 200 (Sub 317 through 322) as detailed in the following pages. These sections generally apply to all procurements using Federal funds. Additionally, subsequent language and forms are specific to the requirements detailed by the Nevada Department of Transportation (NDOT) and the Federal Highway Administration (FHWA) who administers the grant funding this project.

This is a Federal-aid contract and the requirements for such shall apply. On a Federal-aid contract, any Contractor otherwise qualified by the State of Nevada to perform such work is not required to be licensed nor to submit application for license in advance of submitting a bid or having such bid considered, provided, however, that such exception does not constitute a waiver of the City’s right under its license laws to require a Contractor, determined to be a successful bidder, to be licensed to do business in the State of Nevada and the City of Sparks in connection with the award of the contract to them.



FEDERAL FUNDING REQUIREMENTS

The City intends to fund all, or part of the expenditures made under this solicitation and/or resulting contract with federal funds. Therefore, the Offeror (Vendor/Contractor/Consultant) awarded a contract will be subject to compliance with the provisions of 2 CFR 200 UNIFORM ADMINISTRATIVE REQUIREMENTS, COST PRINCIPLES, AND AUDIT REQUIREMENTS FOR FEDERAL AWARDS (aka “Uniform Guidance”), including but not limited to:

1. **Davis-Bacon Act.** If applicable, offeror agrees to comply with all applicable provisions of 40 USC § 3141 – 3148.
2. **Contract Work Hours and Selection Standards.** Offeror agrees to comply with all applicable provisions of 40 USC § 3701 – 3708 to the extent this agreement indicates any employment of mechanics or laborers.
3. **Rights to Invention Made Under Contract or Agreement.** Offeror agrees to comply with all applicable provisions of 37 CFR Part 401.
4. **Clean Air Act, Federal Water Pollution Control Act, and Energy Policy Conservation Act.** Offeror agrees to comply with all applicable provisions of the Clean Air Act under 42 USC § 7401 – 7671, the Energy Federal Water Pollution Control Act 33 USC § 1251 – 1387, and the Energy Policy Conservation Act under 42 USC § 6201.
5. **Debarment and Suspension (Executive Orders 12549 and 12689).** A contract award (see 2 CFR 180.220) must not be made to parties listed on the governmentwide exclusions in the System for Award Management (SAM), in accordance with the OMB guidelines at 2 CFR 180 that implement Executive Orders 12549 (3 CFR part 1986 Comp., p. 189) and 12689 (3 CFR part 1989 Comp., p. 235), “Debarment and Suspension.” SAM Exclusions contains the names of parties debarred, suspended, or otherwise excluded by agencies, as well as parties declared ineligible under statutory or regulatory authority other than Executive Order 12549.
6. **Procurement of Recovered Materials.** Per 2 CFR §200.323, the awarded contractor must comply with section 6002 of the Solid Waste Disposal Act, as amended by the Resource Conservation and Recovery Act. The requirements of Section 6002 include procuring only items designated in guidelines of the Environmental Protection Agency (EPA) at [40 CFR part 247](#) that contain the highest percentage of recovered materials practicable, consistent with maintaining a satisfactory level of competition, where the purchase price of the item exceeds \$10,000; procuring solid waste management services in a manner that maximizes energy and resource recovery; and establishing an affirmative procurement program for procurement of recovered materials identified in the EPA guidelines.
7. **Restrictions on Lobbying.** Offeror is prohibited from using monies for lobbying purposes. The Offeror shall certify to the best of their knowledge that:
 1. No federal appropriated funds have been paid or will be paid to any person for influencing or attempting to influence an officer or employee of any agency, a Member of Congress, an officer or employee of Congress, or an officer or employee of a Member of Congress in connection with the



awarding of any federal contract, the making of any federal loan, the entering into of any cooperative Contract, and the extension, continuation, renewal, amendment, or modification or any federal contract, grant, loan, or cooperative contract; and

2. If any funds other than federal appropriated funds have been paid or will be paid to any person for influencing or attempting to influence an officer or employee of any agency, a Member of Congress, an officer or employee of Congress, or an employee of a Member of Congress in connection with this federal contract, grant, loan, and or cooperative contract, the undersigned shall complete and submit Standard Form – LLL, “Disclosure Form to Report Lobbying”, in accordance with the instructions.
3. The Offeror shall require that the language of this certification be included in the award documents for all sub-awards at all tiers and that all sub-recipients shall certify accordingly.

8. COPELAND ACT (Anti-Kickback Act)

The Copeland Act makes it a criminal offense for any person to induce, by any manner whatsoever, any person employed in the construction, prosecution, completion, or repair of any public building, public work, or building or work financed in whole or in part by loans or grants from the United States, to give up any part of the compensation to which he is entitled under his contract of employment. Incorporated herein and pursuant to 29 CFR 3, the Copeland Act applies to both contractors and subcontractors and prescribes “anti-kickback” regulations under section 2 of the Act of June 13, 1934, as amended (40 USC, Chapter 3, Section 276c and 18 USC, Part 1, Chapter 41, Section 874; and 29 CFR Part 3), popularly known as the Copeland Act. The part is intended to aid in the enforcement of the minimum wage provisions of the Davis-Bacon Act and the various statutes dealing with federally assisted construction that contain similar minimum wage provisions, including those provisions which are not subject to Reorganization Plan No. 14 (e.g., the College Housing Act of 1950, the Federal Water Pollution Control Act, and the Housing Act of 1959), and in the enforcement of the overtime provisions of the Contract Work Hours Standards Act whenever they are applicable to construction work.

- 9. Drug-Free Workplace.** Offeror shall provide a drug free workplace in compliance with the Drug Free Workplace Act of 1988.

10. Civil Rights Compliance.

1. Compliance with Regulations: Offeror will comply with the Acts and the Regulations relative to Nondiscrimination in Federally assisted programs.
2. Nondiscrimination: Offeror, with regard to the work performed by it during the contract, will not discriminate on the grounds of race, color, sex, or national origin in the selection and retention of subcontractors, including procurement of materials and leases of equipment. Offeror will not participate directly or indirectly in the discrimination prohibited by the Acts and the Regulations, including employment practices when the contract covers any activity, project, or program set forth in Appendix B of 45 CFR Part 21.



-
3. **Solicitations for Subcontracts, Including Procurement of Materials and Equipment:** In all solicitations either by competitive bidding or negotiation made by Offeror for work to be performed under a subcontract, including procurement of materials or leases of equipment, each potential subcontractor or supplier will be notified by Offeror of obligations under this contract and the Acts and Regulations relative to Nondiscrimination on the grounds of race, color, sex, or national origin.
 4. **Information and Reports:** Offeror will provide all information and reports required by the Acts, the Regulations, and directives issued pursuant thereto, and will permit access to its books, records, accounts, other sources of information, and facilities as may be determined by to be pertinent to ascertain compliance with such Acts, Regulations or directives. Where any information required of Offeror is in the exclusive possession of another who fails or refuses to furnish this information, Offeror will so certify to and will set forth what efforts it has made to obtain the information.
 5. **Sanctions for Noncompliance:** In the event of Offeror's noncompliance with the Nondiscrimination provisions of this Agreement, the City will impose such sanctions as it may determine to be appropriate, including, but not limited to: withholding of payments to the Offeror under this Agreement until the Offeror compiles and/or cancelling, terminating or suspension of this Agreement, in whole or in part.
 6. **Incorporation of Provisions:** Offeror will include the provisions of the paragraphs listed above, in this section 9.13, in every subcontract, including procurement of materials and leases of equipment, unless exempt by the Acts, the Regulations and directives issued pursuant thereto. Offeror will take such action with respect to any subcontract or procurement as the City, the State, or the Federal agencies may direct as a means of enforcing such provisions including sanctions for noncompliance. Provided, that if Offeror becomes involved in, or is threatened with, litigation with a subcontractor or supplier because of such direction, Offeror may request the State to enter such litigation to protect the interests of the State. In addition, Offeror may request the United States to enter into such litigation to protect the interests of the United States.
 11. **Disadvantaged Business Enterprise Program Requirements.** Offeror shall not discriminate based on race, color, national origin, or sex in the award and performance of any federally assisted contract or in the administration of its DBE program or the requirements of 49 CFR Part 26. Offeror shall take all necessary and reasonable steps under 49 CFR Part 26 to ensure non-discrimination in award and administration of DOT-assisted contracts. Each sub-award or sub-contract must include the following assurance: *The Offeror, sub-recipient, or sub-contractor shall not discriminate on the basis of race, color, national origin, or sex in the performance of this Agreement. The Offeror shall carry out applicable requirements of 49 CFR Part 26 in the award and administration of federally assisted contracts. Failure by the Offeror to carry out these requirements is a material breach of this agreement, which may result in the termination of this agreement or such other remedy as the recipient deems appropriate.*



12. **Pertinent Non-Discrimination Authorities.** During the performance of the awarded contract, Offeror, for itself, its assignees, and successors in interest agree to comply with the following nondiscrimination statutes and authorities; including but not limited to:

1. Title VI of the Civil Rights Act of 1964 (42 U.S.C. § 2000d et seq., 78 stat. 252), (prohibits discrimination based on race, color, national origin); and 49 CFR Part 21.
1. The Uniform Relocation Assistance and Real Property Acquisition Policies Act of 1970, (42 U.S.C. § 4601), (prohibits unfair treatment of persons displaced or whose property has been acquired because of Federal or Federal-aid programs and projects).
2. Federal-Aid Highway Act of 1973, (23 U.S.C. § 324 et seq.), as amended, (prohibits discrimination on the basis of sex).
3. Section 504 of the Rehabilitation Act of 1973, (29 U.S.C. § 794 et seq.) as amended, (prohibits discrimination based on disability); and 49 CFR Part 27.
4. The Age Discrimination Act of 1975, as amended, (49 U.S.C. § 6101 et seq.), (prohibits discrimination based on age).
5. Airport and Airway Improvement Act of 1982, (49 U.S.C. Chapter 471, Section 47123), as amended, (prohibits discrimination based on race, creed, color, national origin, or sex).
6. The Civil Rights Restoration Act of 1987, (PL 100-209), (Broadened the scope, coverage and applicability of Title VI of the Civil Rights Act of 1964, The Age Discrimination Act of 1975 and Section 504 of the Rehabilitation Act of 1973, by expanding the definition of the terms “programs or activities” to include all the programs or activities of the Federal-aid recipients, subrecipients and Offerors, whether such programs or activities are Federally funded or not).
7. Titles II and III of the Americans with Disabilities Act, which prohibits discrimination based on disability in the operation of public entities, public and private transportation systems, places of public accommodation, and certain testing entities (42 U.S.C. §§ 12131-12189) as implemented by Department of Transportation regulations at 49 C.F.R. parts 37 and 38.
8. The Federal Aviation Administration’s Nondiscrimination statute (49 U.S.C. § 47123) (prohibits discrimination based on race, color, national origin, and sex).
9. Executive Order 12898, Federal Actions to Address Environmental Justice in Minority Populations and Low-Income Populations, which ensures nondiscrimination against minority populations by discouraging programs, policies, and activities with disproportionately high and adverse human health or environmental effects on minority and low-income populations.
10. Executive Order 13166, Improving Access to Services for Persons with Limited English Proficiency, and resulting agency guidance, national origin discrimination includes discrimination because of limited English proficiency (LEP). To ensure compliance with Title VI, the parties must take reasonable steps to ensure that LEP persons have meaningful access to the programs (70 Fed. Reg. at 74087 to 74100).
11. Title IX of the Education Amendments of 1972, as amended, which prohibits the parties from discriminating because of sex in education programs or activities (20 U.S.C. 1681 et seq.).

13. **Contracting With Small and Minority Businesses, Women's Business Enterprises, and Labor Surplus Area Firms.** Per 2 CFR 200.321, the awarded contractor must take all necessary affirmative steps to assure that minority businesses, women's business enterprises, and labor surplus area firms are used when possible. If subcontracts are to be let, the awarded prime



contractor is required to take the affirmative steps listed in this section. Affirmative steps must include:

- i. Placing qualified small and minority businesses and women's business enterprises on solicitation lists;
- ii. Assuring that small and minority businesses, and women's business enterprises are solicited whenever they are potential sources;
- iii. Dividing total requirements, when economically feasible, into smaller tasks or quantities to permit maximum participation by small and minority businesses, and women's business enterprises;
- iv. Establishing delivery schedules, where the requirement permits, which encourage participation by small and minority businesses, and women's business enterprises; and
- v. Using the services and assistance, as appropriate, of such organizations as the Small Business Administration and the Minority Business Development Agency of the Department of Commerce.

14. Domestic Preferences for Procurements. Per 2 CFR 200.322, as appropriate and to the extent consistent with law, the City, to the greatest extent practicable under a Federally funded award, provides a preference for the purchase, acquisition, or use of goods, products, or materials produced in the United States (including but not limited to iron, aluminum, steel, cement, and other manufactured products). The requirement of this section includes all subawards including all contracts and purchase orders for work or products under this award. For purposes of this section:

1. "Produced in the United States" means, for iron and steel products, that all manufacturing processes, from the initial melting stage through the application of coatings, occurred in the United States.
2. "Manufactured products" means items and construction materials composed in whole or in part of non-ferrous metals such as aluminum; plastics and polymer-based products such as polyvinyl chloride pipe; aggregates such as concrete; glass, including optical fiber; and lumber.

15. Contract Cost and Price. Per 2 CFR 200.324:

If the cost of the submittal is in excess of \$250,000.00, the City must negotiate profit as a separate element of the submittal's price. To establish a fair and reasonable profit, the City's consideration will be given to the complexity of the work to be performed, the risk borne by the contractor, the contractor's investment, the amount of subcontracting, the quality of its record of past performance, and industry profit rates in the surrounding geographical area for similar work. The cost plus a percentage of cost and percentage of construction cost methods of contracting must not be used.

**a. REQUIRED CONTRACT PROVISIONS
FEDERAL-AID CONSTRUCTION CONTRACTS**

- I. General
- II. Nondiscrimination
- III. Non-segregated Facilities
- IV. Davis-Bacon and Related Act Provisions
- V. Contract Work Hours and Safety Standards Act Provisions
- VI. Subletting or Assigning the Contract
- VII. Safety: Accident Prevention
- VIII. False Statements Concerning Highway Projects
- IX. Implementation of Clean Air Act and Federal Water Pollution Control Act
- X. Certification Regarding Debarment, Suspension, Ineligibility and Voluntary Exclusion
- XI. Certification Regarding Use of Contract Funds for Lobbying
- XII. Use of United States-Flag Vessels:

ATTACHMENTS

A. Employment and Materials Preference for Appalachian Development Highway System or Appalachian Local Access Road Contracts (included in Appalachian contracts only)

I. GENERAL

1. Form FHWA-1273 must be physically incorporated in each construction contract funded under title 23, United States Code, as required in 23 CFR 633.102(b) (excluding emergency contracts solely intended for debris removal). The contractor (or subcontractor) must insert this form in each subcontract and further require its inclusion in all lower tier subcontracts (excluding purchase orders, rental agreements and other agreements for supplies or services). 23 CFR 633.102(e).

The applicable requirements of Form FHWA-1273 are incorporated by reference for work done under any purchase order, rental agreement or agreement for other services. The prime contractor shall be responsible for compliance by any subcontractor, lower-tier subcontractor or service provider. 23 CFR 633.102(e).

Form FHWA-1273 must be included in all Federal-aid design-build contracts, in all subcontracts and in lower tier subcontracts (excluding subcontracts for design services, purchase orders, rental agreements and other agreements for supplies or services) in accordance with 23 CFR 633.102. The design-builder shall be responsible for compliance by any subcontractor, lower-tier subcontractor or service provider.

Contracting agencies may reference Form FHWA-1273 in solicitation-for-bids or request-for-proposals documents, however, the Form FHWA-1273 must be physically incorporated (not referenced) in all contracts, subcontracts and lower-tier subcontracts (excluding purchase orders, rental agreements and other agreements for supplies or services related to a construction contract). 23 CFR 633.102(b).

2. Subject to the applicability criteria noted in the following sections, these contract provisions shall apply to all work

performed on the contract by the contractor's own organization and with the assistance of workers under the contractor's immediate superintendence and to all work performed on the contract by piecework, station work, or by subcontract. 23 CFR 633.102(d).

3. A breach of any of the stipulations contained in these Required Contract Provisions may be sufficient grounds for withholding of progress payments, withholding of final payment, termination of the contract, suspension / debarment or any other action determined to be appropriate by the contracting agency and FHWA.
4. Selection of Labor: During the performance of this contract, the contractor shall not use convict labor for any purpose within the limits of a construction project on a Federal-aid highway unless it is labor performed by convicts who are on parole, supervised release, or probation. 23 U.S.C. 114(b). The term Federal-aid highway does not include roadways functionally classified as local roads or rural minor collectors. 23 U.S.C. 101(a).

II. NONDISCRIMINATION (23 CFR 230.107(a); 23 CFR Part 230, Subpart A, Appendix A; EO 11246)

The provisions of this section related to 23 CFR Part 230, Subpart A, Appendix A are applicable to all Federal-aid construction contracts and to all related construction subcontracts of \$10,000 or more. The provisions of 23 CFR Part 230 are not applicable to material supply, engineering, or architectural service contracts.

In addition, the contractor and all subcontractors must comply with the following policies: Executive Order 11246, 41 CFR Part 60, 29 CFR Parts 1625-1627, 23 U.S.C. 140, Section 504 of the Rehabilitation Act of 1973, as amended (29 U.S.C. 794), Title VI of the Civil Rights Act of 1964, as amended (42 U.S.C. 2000d et seq.), and related regulations including 49 CFR Parts 21, 26, and 27; and 23 CFR Parts 200, 230, and 633.

The contractor and all subcontractors must comply with: the requirements of the Equal Opportunity Clause in 41 CFR 60-1.4(b) and, for all construction contracts exceeding \$10,000, the Standard Federal Equal Employment Opportunity Construction Contract Specifications in 41 CFR 60-4.3.

Note: The U.S. Department of Labor has exclusive authority to determine compliance with Executive Order 11246 and the policies of the Secretary of Labor including 41 CFR Part 60, and 29 CFR Parts 1625-1627. The contracting agency and the FHWA have the authority and the responsibility to ensure compliance with 23 U.S.C. 140, Section 504 of the Rehabilitation Act of 1973, as amended (29 U.S.C. 794), and Title VI of the Civil Rights Act of 1964, as amended (42 U.S.C. 2000d et seq.), and related regulations including 49 CFR Parts 21, 26, and 27; and 23 CFR Parts 200, 230, and 633.

The following provision is adopted from 23 CFR Part 230, Subpart A, Appendix A, with appropriate revisions to conform to the U.S. Department of Labor (US DOL) and FHWA requirements.

1. **Equal Employment Opportunity:** Equal Employment Opportunity (EEO) requirements not to discriminate and to take affirmative action to assure equal opportunity as set forth under laws, executive orders, rules, regulations (see 28 CFR Part 35, 29 CFR Part 1630, 29 CFR Parts 1625-1627, 41 CFR Part 60 and 49 CFR Part 27) and orders of the Secretary of Labor as modified by the provisions prescribed herein, and imposed pursuant to 23 U.S.C. 140, shall constitute the EEO and specific affirmative action standards for the contractor's project activities under this contract. The provisions of the Americans with Disabilities Act of 1990 (42 U.S.C. 12101 et seq.) set forth under 28 CFR Part 35 and 29 CFR Part 1630 are incorporated by reference in this contract. In the execution of this contract, the contractor agrees to comply with the following minimum specific requirement activities of EEO:

a. The contractor will work with the contracting agency and the Federal Government to ensure that it has made every good faith effort to provide equal opportunity with respect to all of its terms and conditions of employment and in their review of activities under the contract. 23 CFR 230.409 (g)(4) & (5).

b. The contractor will accept as its operating policy the following statement:

"It is the policy of this Company to assure that applicants are employed, and that employees are treated during employment, without regard to their race, religion, sex, sexual orientation, gender identity, color, national origin, age or disability. Such action shall include: employment, upgrading, demotion, or transfer; recruitment or recruitment advertising; layoff or termination; rates of pay or other forms of compensation; and selection for training, including apprenticeship, pre-apprenticeship, and/or on-the-job training."

2. **EEO Officer:** The contractor will designate and make known to the contracting officers an EEO Officer who will have the responsibility for and must be capable of effectively administering and promoting an active EEO program and who must be assigned adequate authority and responsibility to do so.

3. **Dissemination of Policy:** All members of the contractor's staff who are authorized to hire, supervise, promote, and discharge employees, or who recommend such action or are substantially involved in such action, will be made fully cognizant of and will implement the contractor's EEO policy and contractual responsibilities to provide EEO in each grade and classification of employment. To ensure that the above agreement will be met, the following actions will be taken as a minimum:

a. Periodic meetings of supervisory and personnel office employees will be conducted before the start of work and then not less often than once every six months, at which time the contractor's EEO policy and its implementation will be reviewed and explained. The meetings will be conducted by the EEO Officer or other knowledgeable company official.

b. All new supervisory or personnel office employees will be given a thorough indoctrination by the EEO Officer, covering all major aspects of the contractor's EEO obligations within thirty days following their reporting for duty with the contractor.

c. All personnel who are engaged in direct recruitment for the project will be instructed by the EEO Officer in the contractor's procedures for locating and hiring minorities and women.

d. Notices and posters setting forth the contractor's EEO policy will be placed in areas readily accessible to employees, applicants for employment and potential employees.

e. The contractor's EEO policy and the procedures to implement such policy will be brought to the attention of employees by means of meetings, employee handbooks, or other appropriate means.

4. **Recruitment:** When advertising for employees, the contractor will include in all advertisements for employees the notation: "An Equal Opportunity Employer." All such advertisements will be placed in publications having a large circulation among minorities and women in the area from which the project work force would normally be derived.

a. The contractor will, unless precluded by a valid bargaining agreement, conduct systematic and direct recruitment through public and private employee referral sources likely to yield qualified minorities and women. To meet this requirement, the contractor will identify sources of potential minority group employees and establish with such identified sources procedures whereby minority and women applicants may be referred to the contractor for employment consideration.

b. In the event the contractor has a valid bargaining agreement providing for exclusive hiring hall referrals, the contractor is expected to observe the provisions of that agreement to the extent that the system meets the contractor's compliance with EEO contract provisions. Where implementation of such an agreement has the effect of discriminating against minorities or women, or obligates the contractor to do the same, such implementation violates Federal nondiscrimination provisions.

c. The contractor will encourage its present employees to refer minorities and women as applicants for employment. Information and procedures with regard to referring such applicants will be discussed with employees.

5. **Personnel Actions:** Wages, working conditions, and employee benefits shall be established and administered, and personnel actions of every type, including hiring, upgrading, promotion, transfer, demotion, layoff, and termination, shall be taken without regard to race, color, religion, sex, sexual orientation, gender identity, national origin, age or disability. The following procedures shall be followed:

a. The contractor will conduct periodic inspections of project sites to ensure that working conditions and employee facilities do not indicate discriminatory treatment of project site personnel.

b. The contractor will periodically evaluate the spread of wages paid within each classification to determine any evidence of discriminatory wage practices.

c. The contractor will periodically review selected personnel actions in depth to determine whether there is evidence of discrimination. Where evidence is found, the contractor will promptly take corrective action. If the review indicates that the discrimination may extend beyond the actions reviewed, such corrective action shall include all affected persons.

d. The contractor will promptly investigate all complaints of alleged discrimination made to the contractor in connection with its obligations under this contract, will attempt to resolve such complaints, and will take appropriate corrective action

within a reasonable time. If the investigation indicates that the discrimination may affect persons other than the complainant, such corrective action shall include such other persons. Upon completion of each investigation, the contractor will inform every complainant of all of their avenues of appeal.

6. Training and Promotion:

a. The contractor will assist in locating, qualifying, and increasing the skills of minorities and women who are applicants for employment or current employees. Such efforts should be aimed at developing full journey level status employees in the type of trade or job classification involved.

b. Consistent with the contractor's work force requirements and as permissible under Federal and State regulations, the contractor shall make full use of training programs (i.e., apprenticeship and on-the-job training programs for the geographical area of contract performance). In the event a special provision for training is provided under this contract, this subparagraph will be superseded as indicated in the special provision. The contracting agency may reserve training positions for persons who receive welfare assistance in accordance with 23 U.S.C. 140(a).

c. The contractor will advise employees and applicants for employment of available training programs and entrance requirements for each.

d. The contractor will periodically review the training and promotion potential of employees who are minorities and women and will encourage eligible employees to apply for such training and promotion.

7. Unions: If the contractor relies in whole or in part upon unions as a source of employees, the contractor will use good faith efforts to obtain the cooperation of such unions to increase opportunities for minorities and women. 23 CFR 230.409. Actions by the contractor, either directly or through a contractor's association acting as agent, will include the procedures set forth below:

b. The contractor will use good faith efforts to develop, in cooperation with the unions, joint training programs aimed toward qualifying more minorities and women for membership in the unions and increasing the skills of minorities and women so that they may qualify for higher paying employment.

c. The contractor will use good faith efforts to incorporate an EEO clause into each union agreement to the end that such union will be contractually bound to refer applicants without regard to their race, color, religion, sex, sexual orientation, gender identity, national origin, age, or disability.

d. The contractor is to obtain information as to the referral practices and policies of the labor union except that to the extent such information is within the exclusive possession of the labor union and such labor union refuses to furnish such information to the contractor, the contractor shall so certify to the contracting agency and shall set forth what efforts have been made to obtain such information.

e. In the event the union is unable to provide the contractor with a reasonable flow of referrals within the time limit set forth in the collective bargaining agreement, the contractor will, through independent recruitment efforts, fill the employment vacancies without regard to race, color, religion, sex, sexual orientation, gender identity, national origin, age, or disability; making full efforts to obtain qualified and/or qualifiable minorities and women. The failure of a union to provide

sufficient referrals (even though it is obligated to provide exclusive referrals under the terms of a collective bargaining agreement) does not relieve the contractor from the requirements of this paragraph. In the event the union referral practice prevents the contractor from meeting the obligations pursuant to Executive Order 11246, as amended, and these special provisions, such contractor shall immediately notify the contracting agency.

8. Reasonable Accommodation for Applicants / Employees with Disabilities: The contractor must be familiar with the requirements for and comply with the Americans with Disabilities Act and all rules and regulations established thereunder. Employers must provide reasonable accommodation in all employment activities unless to do so would cause an undue hardship.

9. Selection of Subcontractors, Procurement of Materials and Leasing of Equipment: The contractor shall not discriminate on the grounds of race, color, religion, sex, sexual orientation, gender identity, national origin, age, or disability in the selection and retention of subcontractors, including procurement of materials and leases of equipment. The contractor shall take all necessary and reasonable steps to ensure nondiscrimination in the administration of this contract.

a. The contractor shall notify all potential subcontractors, suppliers, and lessors of their EEO obligations under this contract.

b. The contractor will use good faith efforts to ensure subcontractor compliance with their EEO obligations.

10. Assurances Required:

a. The requirements of 49 CFR Part 26 and the State DOT's FHWA-approved Disadvantaged Business Enterprise (DBE) program are incorporated by reference.

b. The contractor, subrecipient or subcontractor shall not discriminate on the basis of race, color, national origin, or sex in the performance of this contract. The contractor shall carry out applicable requirements of 49 CFR part 26 in the award and administration of DOT-assisted contracts. Failure by the contractor to carry out these requirements is a material breach of this contract, which may result in the termination of this contract or such other remedy as the recipient deems appropriate, which may include, but is not limited to:

- (1) Withholding monthly progress payments;
- (2) Assessing sanctions;
- (3) Liquidated damages; and/or
- (4) Disqualifying the contractor from future bidding as non-responsible.

c. The Title VI and nondiscrimination provisions of U.S. DOT Order 1050.2A at Appendixes A and E are incorporated by reference. 49 CFR Part 21.

11. Records and Reports: The contractor shall keep such records as necessary to document compliance with the EEO requirements. Such records shall be retained for a period of three years following the date of the final payment to the contractor for all contract work and shall be available at reasonable times and places for inspection by authorized representatives of the contracting agency and the FHWA.

a. The records kept by the contractor shall document the following:

(1) The number and work hours of minority and non-minority group members and women employed in each work classification on the project;

(2) The progress and efforts being made in cooperation with unions, when applicable, to increase employment opportunities for minorities and women; and

(3) The progress and efforts being made in locating, hiring, training, qualifying, and upgrading minorities and women.

b. The contractors and subcontractors will submit an annual report to the contracting agency each July for the duration of the project indicating the number of minority, women, and non-minority group employees currently engaged in each work classification required by the contract work. This information is to be reported on [Form FHWA-1391](#). The staffing data should represent the project work force on board in all or any part of the last payroll period preceding the end of July. If on-the-job training is being required by special provision, the contractor will be required to collect and report training data. The employment data should reflect the work force on board during all or any part of the last payroll period preceding the end of July.

III. NONSEGREGATED FACILITIES

This provision is applicable to all Federal-aid construction contracts and to all related construction subcontracts of more than \$10,000. 41 CFR 60-1.5.

As prescribed by 41 CFR 60-1.8, the contractor must ensure that facilities provided for employees are provided in such a manner that segregation on the basis of race, color, religion, sex, sexual orientation, gender identity, or national origin cannot result. The contractor may neither require such segregated use by written or oral policies nor tolerate such use by employee custom. The contractor's obligation extends further to ensure that its employees are not assigned to perform their services at any location under the contractor's control where the facilities are segregated. The term "facilities" includes waiting rooms, work areas, restaurants and other eating areas, time clocks, restrooms, washrooms, locker rooms and other storage or dressing areas, parking lots, drinking fountains, recreation or entertainment areas, transportation, and housing provided for employees. The contractor shall provide separate or single-user restrooms and necessary dressing or sleeping areas to assure privacy between sexes.

IV. DAVIS-BACON AND RELATED ACT PROVISIONS

This section is applicable to all Federal-aid construction projects exceeding \$2,000 and to all related subcontracts and lower-tier subcontracts (regardless of subcontract size), in accordance with 29 CFR 5.5. The requirements apply to all projects located within the right-of-way of a roadway that is functionally classified as Federal-aid highway. 23 U.S.C. 113. This excludes roadways functionally classified as local roads or rural minor collectors, which are exempt. 23 U.S.C. 101. Where applicable law requires that projects be treated as a project on a Federal-aid highway, the provisions of this subpart will apply regardless of the location of the project. Examples include: Surface Transportation Block Grant Program projects funded under 23 U.S.C. 133 [excluding recreational trails projects], the Nationally Significant Freight and Highway

Projects funded under 23 U.S.C. 117, and National Highway Freight Program projects funded under 23 U.S.C. 167.

The following provisions are from the U.S. Department of Labor regulations in 29 CFR 5.5 "Contract provisions and related matters" with minor revisions to conform to the FHWA- 1273 format and FHWA program requirements.

1. Minimum wages (29 CFR 5.5)

a. *Wage rates and fringe benefits.* All laborers and mechanics employed or working upon the site of the work (or otherwise working in construction or development of the project under a development statute), will be paid unconditionally and not less often than once a week, and without subsequent deduction or rebate on any account (except such payroll deductions as are permitted by regulations issued by the Secretary of Labor under the Copeland Act ([29 CFR part 3](#))), the full amount of basic hourly wages and bona fide fringe benefits (or cash equivalents thereof) due at time of payment computed at rates not less than those contained in the wage determination of the Secretary of Labor which is attached hereto and made a part hereof, regardless of any contractual relationship which may be alleged to exist between the contractor and such laborers and mechanics. As provided in paragraphs (d) and (e) of 29 CFR 5.5, the appropriate wage determinations are effective by operation of law even if they have not been attached to the contract. Contributions made or costs reasonably anticipated for bona fide fringe benefits under the Davis-Bacon Act ([40 U.S.C. 3141\(2\)\(B\)](#)) on behalf of laborers or mechanics are considered wages paid to such laborers or mechanics, subject to the provisions of paragraph 1.e. of this section; also, regular contributions made or costs incurred for more than a weekly period (but not less often than quarterly) under plans, funds, or programs which cover the particular weekly period, are deemed to be constructively made or incurred during such weekly period. Such laborers and mechanics must be paid the appropriate wage rate and fringe benefits on the wage determination for the classification(s) of work actually performed, without regard to skill, except as provided in paragraph 4. of this section. Laborers or mechanics performing work in more than one classification may be compensated at the rate specified for each classification for the time actually worked therein: *Provided*, That the employer's payroll records accurately set forth the time spent in each classification in which work is performed. The wage determination (including any additional classifications and wage rates conformed under paragraph 1.c. of this section) and the Davis-Bacon poster (WH-1321) must be posted at all times by the contractor and its subcontractors at the site of the work in a prominent and accessible place where it can be easily seen by the workers.

b. *Frequently recurring classifications.* (1) In addition to wage and fringe benefit rates that have been determined to be prevailing under the procedures set forth in [29 CFR part 1](#), a wage determination may contain, pursuant to § 1.3(f), wage and fringe benefit rates for classifications of laborers and mechanics for which conformance requests are regularly submitted pursuant to paragraph 1.c. of this section, provided that:

(i) The work performed by the classification is not performed by a classification in the wage determination for which a prevailing wage rate has been determined;

(ii) The classification is used in the area by the construction industry; and

(iii) The wage rate for the classification bears a reasonable relationship to the prevailing wage rates contained in the wage determination.

(2) The Administrator will establish wage rates for such classifications in accordance with paragraph 1.c.(1)(iii) of this section. Work performed in such a classification must be paid at no less than the wage and fringe benefit rate listed on the wage determination for such classification.

c. *Conformance.* (1) The contracting officer must require that any class of laborers or mechanics, including helpers, which is not listed in the wage determination and which is to be employed under the contract be classified in conformance with the wage determination. Conformance of an additional classification and wage rate and fringe benefits is appropriate only when the following criteria have been met:

(i) The work to be performed by the classification requested is not performed by a classification in the wage determination; and

(ii) The classification is used in the area by the construction industry; and

(iii) The proposed wage rate, including any bona fide fringe benefits, bears a reasonable relationship to the wage rates contained in the wage determination.

(2) The conformance process may not be used to split, subdivide, or otherwise avoid application of classifications listed in the wage determination.

(3) If the contractor and the laborers and mechanics to be employed in the classification (if known), or their representatives, and the contracting officer agree on the classification and wage rate (including the amount designated for fringe benefits where appropriate), a report of the action taken will be sent by the contracting officer by email to DBAconformance@dol.gov. The Administrator, or an authorized representative, will approve, modify, or disapprove every additional classification action within 30 days of receipt and so advise the contracting officer or will notify the contracting officer within the 30-day period that additional time is necessary.

(4) In the event the contractor, the laborers or mechanics to be employed in the classification or their representatives, and the contracting officer do not agree on the proposed classification and wage rate (including the amount designated for fringe benefits, where appropriate), the contracting officer will, by email to DBAconformance@dol.gov, refer the questions, including the views of all interested parties and the recommendation of the contracting officer, to the Administrator for determination. The Administrator, or an authorized representative, will issue a determination within 30 days of receipt and so advise the contracting officer or will notify the contracting officer within the 30-day period that additional time is necessary.

(5) The contracting officer must promptly notify the contractor of the action taken by the Wage and Hour Division

under paragraphs 1.c.(3) and (4) of this section. The contractor must furnish a written copy of such determination to each affected worker or it must be posted as a part of the wage determination. The wage rate (including fringe benefits where appropriate) determined pursuant to paragraph 1.c.(3) or (4) of this section must be paid to all workers performing work in the classification under this contract from the first day on which work is performed in the classification.

d. *Fringe benefits not expressed as an hourly rate.*

Whenever the minimum wage rate prescribed in the contract for a class of laborers or mechanics includes a fringe benefit which is not expressed as an hourly rate, the contractor may either pay the benefit as stated in the wage determination or may pay another bona fide fringe benefit or an hourly cash equivalent thereof.

e. *Unfunded plans.* If the contractor does not make payments to a trustee or other third person, the contractor may consider as part of the wages of any laborer or mechanic the amount of any costs reasonably anticipated in providing bona fide fringe benefits under a plan or program, *Provided*, That the Secretary of Labor has found, upon the written request of the contractor, in accordance with the criteria set forth in § 5.28, that the applicable standards of the Davis-Bacon Act have been met. The Secretary of Labor may require the contractor to set aside in a separate account assets for the meeting of obligations under the plan or program.

f. *Interest.* In the event of a failure to pay all or part of the wages required by the contract, the contractor will be required to pay interest on any underpayment of wages.

2. **Withholding** (29 CFR 5.5)

a. *Withholding requirements.* The contracting agency may, upon its own action, or must, upon written request of an authorized representative of the Department of Labor, withhold or cause to be withheld from the contractor so much of the accrued payments or advances as may be considered necessary to satisfy the liabilities of the prime contractor or any subcontractor for the full amount of wages and monetary relief, including interest, required by the clauses set forth in this section for violations of this contract, or to satisfy any such liabilities required by any other Federal contract, or federally assisted contract subject to Davis-Bacon labor standards, that is held by the same prime contractor (as defined in § 5.2). The necessary funds may be withheld from the contractor under this contract, any other Federal contract with the same prime contractor, or any other federally assisted contract that is subject to Davis-Bacon labor standards requirements and is held by the same prime contractor, regardless of whether the other contract was awarded or assisted by the same agency, and such funds may be used to satisfy the contractor liability for which the funds were withheld. In the event of a contractor's failure to pay any laborer or mechanic, including any apprentice or helper working on the site of the work all or part of the wages required by the contract, or upon the contractor's failure to submit the required records as discussed in paragraph 3.d. of this section, the contracting agency may on its own initiative and after written notice to the contractor, take such action as may be necessary to cause the suspension of any further payment, advance, or guarantee of funds until such violations have ceased.

b. *Priority to withheld funds.* The Department has priority to funds withheld or to be withheld in accordance with paragraph

2.a. of this section or Section V, paragraph 3.a., or both, over claims to those funds by:

- (1) A contractor's surety(ies), including without limitation performance bond sureties and payment bond sureties;
- (2) A contracting agency for its procurement costs;
- (3) A trustee(s) (either a court-appointed trustee or a U.S. trustee, or both) in bankruptcy of a contractor, or a contractor's bankruptcy estate;
- (4) A contractor's assignee(s);
- (5) A contractor's successor(s); or
- (6) A claim asserted under the Prompt Payment Act, [31 U.S.C. 3901–3907](#).

3. Records and certified payrolls (29 CFR 5.5)

a. Basic record requirements (1) Length of record retention. All regular payrolls and other basic records must be maintained by the contractor and any subcontractor during the course of the work and preserved for all laborers and mechanics working at the site of the work (or otherwise working in construction or development of the project under a development statute) for a period of at least 3 years after all the work on the prime contract is completed.

(2) Information required. Such records must contain the name; Social Security number; last known address, telephone number, and email address of each such worker; each worker's correct classification(s) of work actually performed; hourly rates of wages paid (including rates of contributions or costs anticipated for bona fide fringe benefits or cash equivalents thereof of the types described in [40 U.S.C. 3141\(2\)\(B\)](#) of the Davis-Bacon Act); daily and weekly number of hours actually worked in total and on each covered contract; deductions made; and actual wages paid.

(3) Additional records relating to fringe benefits. Whenever the Secretary of Labor has found under paragraph 1.e. of this section that the wages of any laborer or mechanic include the amount of any costs reasonably anticipated in providing benefits under a plan or program described in [40 U.S.C. 3141\(2\)\(B\)](#) of the Davis-Bacon Act, the contractor must maintain records which show that the commitment to provide such benefits is enforceable, that the plan or program is financially responsible, and that the plan or program has been communicated in writing to the laborers or mechanics affected, and records which show the costs anticipated or the actual cost incurred in providing such benefits.

(4) Additional records relating to apprenticeship. Contractors with apprentices working under approved programs must maintain written evidence of the registration of apprenticeship programs, the registration of the apprentices, and the ratios and wage rates prescribed in the applicable programs.

b. Certified payroll requirements (1) Frequency and method of submission. The contractor or subcontractor must submit weekly, for each week in which any DBA- or Related Acts-covered work is performed, certified payrolls to the contracting

agency. The prime contractor is responsible for the submission of all certified payrolls by all subcontractors. A contracting agency or prime contractor may permit or require contractors to submit certified payrolls through an electronic system, as long as the electronic system requires a legally valid electronic signature; the system allows the contractor, the contracting agency, and the Department of Labor to access the certified payrolls upon request for at least 3 years after the work on the prime contract has been completed; and the contracting agency or prime contractor permits other methods of submission in situations where the contractor is unable or limited in its ability to use or access the electronic system.

(2) Information required. The certified payrolls submitted must set out accurately and completely all of the information required to be maintained under paragraph 3.a.(2) of this section, except that full Social Security numbers and last known addresses, telephone numbers, and email addresses must not be included on weekly transmittals. Instead, the certified payrolls need only include an individually identifying number for each worker (e.g., the last four digits of the worker's Social Security number). The required weekly certified payroll information may be submitted using Optional Form WH-347 or in any other format desired. Optional Form WH-347 is available for this purpose from the Wage and Hour Division website at <https://www.dol.gov/sites/dolgov/files/WHDLegacy/files/wh347.pdf> or its successor website. It is not a violation of this section for a prime contractor to require a subcontractor to provide full Social Security numbers and last known addresses, telephone numbers, and email addresses to the prime contractor for its own records, without weekly submission by the subcontractor to the contracting agency.

(3) Statement of Compliance. Each certified payroll submitted must be accompanied by a "Statement of Compliance," signed by the contractor or subcontractor, or the contractor's or subcontractor's agent who pays or supervises the payment of the persons working on the contract, and must certify the following:

(i) That the certified payroll for the payroll period contains the information required to be provided under paragraph 3.b. of this section, the appropriate information and basic records are being maintained under paragraph 3.a. of this section, and such information and records are correct and complete;

(ii) That each laborer or mechanic (including each helper and apprentice) working on the contract during the payroll period has been paid the full weekly wages earned, without rebate, either directly or indirectly, and that no deductions have been made either directly or indirectly from the full wages earned, other than permissible deductions as set forth in [29 CFR part 3](#); and

(iii) That each laborer or mechanic has been paid not less than the applicable wage rates and fringe benefits or cash equivalents for the classification(s) of work actually performed, as specified in the applicable wage determination incorporated into the contract.

(4) Use of Optional Form WH-347. The weekly submission of a properly executed certification set forth on the reverse side of Optional Form WH-347 will satisfy the requirement for submission of the "Statement of Compliance" required by paragraph 3.b.(3) of this section.

(5) *Signature*. The signature by the contractor, subcontractor, or the contractor's or subcontractor's agent must be an original handwritten signature or a legally valid electronic signature.

(6) *Falsification*. The falsification of any of the above certifications may subject the contractor or subcontractor to civil or criminal prosecution under [18 U.S.C. 1001](#) and [31 U.S.C. 3729](#).

(7) *Length of certified payroll retention*. The contractor or subcontractor must preserve all certified payrolls during the course of the work and for a period of 3 years after all the work on the prime contract is completed.

c. *Contracts, subcontracts, and related documents*. The contractor or subcontractor must maintain this contract or subcontract and related documents including, without limitation, bids, proposals, amendments, modifications, and extensions. The contractor or subcontractor must preserve these contracts, subcontracts, and related documents during the course of the work and for a period of 3 years after all the work on the prime contract is completed.

d. *Required disclosures and access* (1) *Required record disclosures and access to workers*. The contractor or subcontractor must make the records required under paragraphs 3.a. through 3.c. of this section, and any other documents that the contracting agency, the State DOT, the FHWA, or the Department of Labor deems necessary to determine compliance with the labor standards provisions of any of the applicable statutes referenced by § 5.1, available for inspection, copying, or transcription by authorized representatives of the contracting agency, the State DOT, the FHWA, or the Department of Labor, and must permit such representatives to interview workers during working hours on the job.

(2) *Sanctions for non-compliance with records and worker access requirements*. If the contractor or subcontractor fails to submit the required records or to make them available, or refuses to permit worker interviews during working hours on the job, the Federal agency may, after written notice to the contractor, sponsor, applicant, owner, or other entity, as the case may be, that maintains such records or that employs such workers, take such action as may be necessary to cause the suspension of any further payment, advance, or guarantee of funds. Furthermore, failure to submit the required records upon request or to make such records available, or to permit worker interviews during working hours on the job, may be grounds for debarment action pursuant to § 5.12. In addition, any contractor or other person that fails to submit the required records or make those records available to WHD within the time WHD requests that the records be produced will be precluded from introducing as evidence in an administrative proceeding under [29 CFR part 6](#) any of the required records that were not provided or made available to WHD. WHD will take into consideration a reasonable request from the contractor or person for an extension of the time for submission of records. WHD will determine the reasonableness of the request and may consider, among other things, the location of the records and the volume of production.

(3) *Required information disclosures*. Contractors and subcontractors must maintain the full Social Security number and last known address, telephone number, and email address

of each covered worker, and must provide them upon request to the contracting agency, the State DOT, the FHWA, the contractor, or the Wage and Hour Division of the Department of Labor for purposes of an investigation or other compliance action.

4. **Apprentices and equal employment opportunity** (29 CFR 5.5)

a. *Apprentices* (1) *Rate of pay*. Apprentices will be permitted to work at less than the predetermined rate for the work they perform when they are employed pursuant to and individually registered in a bona fide apprenticeship program registered with the U.S. Department of Labor, Employment and Training Administration, Office of Apprenticeship (OA), or with a State Apprenticeship Agency recognized by the OA. A person who is not individually registered in the program, but who has been certified by the OA or a State Apprenticeship Agency (where appropriate) to be eligible for probationary employment as an apprentice, will be permitted to work at less than the predetermined rate for the work they perform in the first 90 days of probationary employment as an apprentice in such a program. In the event the OA or a State Apprenticeship Agency recognized by the OA withdraws approval of an apprenticeship program, the contractor will no longer be permitted to use apprentices at less than the applicable predetermined rate for the work performed until an acceptable program is approved.

(2) *Fringe benefits*. Apprentices must be paid fringe benefits in accordance with the provisions of the apprenticeship program. If the apprenticeship program does not specify fringe benefits, apprentices must be paid the full amount of fringe benefits listed on the wage determination for the applicable classification. If the Administrator determines that a different practice prevails for the applicable apprentice classification, fringe benefits must be paid in accordance with that determination.

(3) *Apprenticeship ratio*. The allowable ratio of apprentices to journeymen on the job site in any craft classification must not be greater than the ratio permitted to the contractor as to the entire work force under the registered program or the ratio applicable to the locality of the project pursuant to paragraph 4.a.(4) of this section. Any worker listed on a payroll at an apprentice wage rate, who is not registered or otherwise employed as stated in paragraph 4.a.(1) of this section, must be paid not less than the applicable wage rate on the wage determination for the classification of work actually performed. In addition, any apprentice performing work on the job site in excess of the ratio permitted under this section must be paid not less than the applicable wage rate on the wage determination for the work actually performed.

(4) *Reciprocity of ratios and wage rates*. Where a contractor is performing construction on a project in a locality other than the locality in which its program is registered, the ratios and wage rates (expressed in percentages of the journeyworker's hourly rate) applicable within the locality in which the construction is being performed must be observed. If there is no applicable ratio or wage rate for the locality of the project, the ratio and wage rate specified in the contractor's registered program must be observed.

b. *Equal employment opportunity*. The use of apprentices and journeymen under this part must be in conformity with

the equal employment opportunity requirements of Executive Order 11246, as amended, and [29 CFR part 30](#).

c. Apprentices and Trainees (programs of the U.S. DOT).

Apprentices and trainees working under apprenticeship and skill training programs which have been certified by the Secretary of Transportation as promoting EEO in connection with Federal-aid highway construction programs are not subject to the requirements of paragraph 4 of this Section IV. 23 CFR 230.111(e)(2). The straight time hourly wage rates for apprentices and trainees under such programs will be established by the particular programs. The ratio of apprentices and trainees to journeyworkers shall not be greater than permitted by the terms of the particular program.

5. **Compliance with Copeland Act requirements.** The contractor shall comply with the requirements of 29 CFR part 3, which are incorporated by reference in this contract as provided in 29 CFR 5.5.

6. **Subcontracts.** The contractor or subcontractor must insert FHWA-1273 in any subcontracts, along with the applicable wage determination(s) and such other clauses or contract modifications as the contracting agency may by appropriate instructions require, and a clause requiring the subcontractors to include these clauses and wage determination(s) in any lower tier subcontracts. The prime contractor is responsible for the compliance by any subcontractor or lower tier subcontractor with all the contract clauses in this section. In the event of any violations of these clauses, the prime contractor and any subcontractor(s) responsible will be liable for any unpaid wages and monetary relief, including interest from the date of the underpayment or loss, due to any workers of lower-tier subcontractors, and may be subject to debarment, as appropriate. 29 CFR 5.5.

7. **Contract termination: debarment.** A breach of the contract clauses in 29 CFR 5.5 may be grounds for termination of the contract, and for debarment as a contractor and a subcontractor as provided in 29 CFR 5.12.

8. **Compliance with Davis-Bacon and Related Act requirements.** All rulings and interpretations of the Davis-Bacon and Related Acts contained in 29 CFR parts 1, 3, and 5 are herein incorporated by reference in this contract as provided in 29 CFR 5.5.

9. **Disputes concerning labor standards.** As provided in 29 CFR 5.5, disputes arising out of the labor standards provisions of this contract shall not be subject to the general disputes clause of this contract. Such disputes shall be resolved in accordance with the procedures of the Department of Labor set forth in 29 CFR parts 5, 6, and 7. Disputes within the meaning of this clause include disputes between the contractor (or any of its subcontractors) and the contracting agency, the U.S. Department of Labor, or the employees or their representatives.

10. **Certification of eligibility.** a. By entering into this contract, the contractor certifies that neither it nor any person or firm who has an interest in the contractor's firm is a person or firm ineligible to be awarded Government contracts by virtue of [40 U.S.C. 3144\(b\)](#) or § 5.12(a).

b. No part of this contract shall be subcontracted to any person or firm ineligible for award of a Government contract by virtue of [40 U.S.C. 3144\(b\)](#) or § 5.12(a).

c. The penalty for making false statements is prescribed in the U.S. Code, Title 18 Crimes and Criminal Procedure, [18 U.S.C. 1001](#).

11. **Anti-retaliation.** It is unlawful for any person to discharge, demote, intimidate, threaten, restrain, coerce, blacklist, harass, or in any other manner discriminate against, or to cause any person to discharge, demote, intimidate, threaten, restrain, coerce, blacklist, harass, or in any other manner discriminate against, any worker or job applicant for:

a. Notifying any contractor of any conduct which the worker reasonably believes constitutes a violation of the DBA, Related Acts, this part, or [29 CFR part 1](#) or [3](#);

b. Filing any complaint, initiating or causing to be initiated any proceeding, or otherwise asserting or seeking to assert on behalf of themselves or others any right or protection under the DBA, Related Acts, this part, or [29 CFR part 1](#) or [3](#);

c. Cooperating in any investigation or other compliance action, or testifying in any proceeding under the DBA, Related Acts, this part, or [29 CFR part 1](#) or [3](#); or

d. Informing any other person about their rights under the DBA, Related Acts, this part, or [29 CFR part 1](#) or [3](#).

V. CONTRACT WORK HOURS AND SAFETY STANDARDS ACT

Pursuant to 29 CFR 5.5(b), the following clauses apply to any Federal-aid construction contract in an amount in excess of \$100,000 and subject to the overtime provisions of the Contract Work Hours and Safety Standards Act. These clauses shall be inserted in addition to the clauses required by 29 CFR 5.5(a) or 29 CFR 4.6. As used in this paragraph, the terms laborers and mechanics include watchpersons and guards.

1. **Overtime requirements.** No contractor or subcontractor contracting for any part of the contract work which may require or involve the employment of laborers or mechanics shall require or permit any such laborer or mechanic in any workweek in which he or she is employed on such work to work in excess of forty hours in such workweek unless such laborer or mechanic receives compensation at a rate not less than one and one-half times the basic rate of pay for all hours worked in excess of forty hours in such workweek. 29 CFR 5.5.

2. **Violation; liability for unpaid wages; liquidated damages.** In the event of any violation of the clause set forth in paragraph 1. of this section the contractor and any subcontractor responsible therefor shall be liable for the unpaid wages and interest from the date of the underpayment. In addition, such contractor and subcontractor shall be liable to the United States (in the case of work done under contract for the District of Columbia or a territory, to such District or to such territory), for liquidated damages. Such liquidated damages shall be computed with respect to each individual laborer or

mechanic, including watchpersons and guards, employed in violation of the clause set forth in paragraph 1. of this section, in the sum currently provided in 29 CFR 5.5(b)(2)* for each calendar day on which such individual was required or permitted to work in excess of the standard workweek of forty hours without payment of the overtime wages required by the clause set forth in paragraph 1. of this section.

* \$31 as of January 15, 2023 (See 88 FR 88 FR 2210) as may be adjusted annually by the Department of Labor, pursuant to the Federal Civil Penalties Inflation Adjustment Act of 1990.

3. Withholding for unpaid wages and liquidated damages

a. *Withholding process.* The FHWA or the contracting agency may, upon its own action, or must, upon written request of an authorized representative of the Department of Labor, withhold or cause to be withheld from the contractor so much of the accrued payments or advances as may be considered necessary to satisfy the liabilities of the prime contractor or any subcontractor for any unpaid wages; monetary relief, including interest; and liquidated damages required by the clauses set forth in this section on this contract, any other Federal contract with the same prime contractor, or any other federally assisted contract subject to the Contract Work Hours and Safety Standards Act that is held by the same prime contractor (as defined in § 5.2). The necessary funds may be withheld from the contractor under this contract, any other Federal contract with the same prime contractor, or any other federally assisted contract that is subject to the Contract Work Hours and Safety Standards Act and is held by the same prime contractor, regardless of whether the other contract was awarded or assisted by the same agency, and such funds may be used to satisfy the contractor liability for which the funds were withheld.

b. *Priority to withheld funds.* The Department has priority to funds withheld or to be withheld in accordance with Section IV paragraph 2.a. or paragraph 3.a. of this section, or both, over claims to those funds by:

- (1) A contractor's surety(ies), including without limitation performance bond sureties and payment bond sureties;
- (2) A contracting agency for its procurement costs;
- (3) A trustee(s) (either a court-appointed trustee or a U.S. trustee, or both) in bankruptcy of a contractor, or a contractor's bankruptcy estate;
- (4) A contractor's assignee(s);
- (5) A contractor's successor(s); or
- (6) A claim asserted under the Prompt Payment Act, [31 U.S.C. 3901](#)–3907.

4. **Subcontracts.** The contractor or subcontractor must insert in any subcontracts the clauses set forth in paragraphs 1. through 5. of this section and a clause requiring the subcontractors to include these clauses in any lower tier subcontracts. The prime contractor is responsible for compliance by any subcontractor or lower tier subcontractor with the clauses set forth in paragraphs 1. through 5. In the

event of any violations of these clauses, the prime contractor and any subcontractor(s) responsible will be liable for any unpaid wages and monetary relief, including interest from the date of the underpayment or loss, due to any workers of lower- tier subcontractors, and associated liquidated damages and may be subject to debarment, as appropriate.

5. **Anti-retaliation.** It is unlawful for any person to discharge, demote, intimidate, threaten, restrain, coerce, blacklist, harass, or in any other manner discriminate against, or to cause any person to discharge, demote, intimidate, threaten, restrain, coerce, blacklist, harass, or in any other manner discriminate against, any worker or job applicant for:

a. Notifying any contractor of any conduct which the worker reasonably believes constitutes a violation of the Contract Work Hours and Safety Standards Act (CWHSSA) or its implementing regulations in this part;

b. Filing any complaint, initiating or causing to be initiated any proceeding, or otherwise asserting or seeking to assert on behalf of themselves or others any right or protection under CWHSSA or this part;

c. Cooperating in any investigation or other compliance action, or testifying in any proceeding under CWHSSA or this part; or

d. Informing any other person about their rights under CWHSSA or this part.

VI. SUBLETTING OR ASSIGNING THE CONTRACT

This provision is applicable to all Federal-aid construction contracts on the National Highway System pursuant to 23 CFR 635.116.

1. The contractor shall perform with its own organization contract work amounting to not less than 30 percent (or a greater percentage if specified elsewhere in the contract) of the total original contract price, excluding any specialty items designated by the contracting agency. Specialty items may be performed by subcontract and the amount of any such specialty items performed may be deducted from the total original contract price before computing the amount of work required to be performed by the contractor's own organization (23 CFR 635.116).

a. The term "perform work with its own organization" in paragraph 1 of Section VI refers to workers employed or leased by the prime contractor, and equipment owned or rented by the prime contractor, with or without operators. Such term does not include employees or equipment of a subcontractor or lower tier subcontractor, agents of the prime contractor, or any other assignees. The term may include payments for the costs of hiring leased employees from an employee leasing firm meeting all relevant Federal and State regulatory requirements. Leased employees may only be included in this term if the prime contractor meets all of the following conditions: (based on longstanding interpretation)

(1) the prime contractor maintains control over the supervision of the day-to-day activities of the leased employees;

(2) the prime contractor remains responsible for the quality of the work of the leased employees;

- (3) the prime contractor retains all power to accept or exclude individual employees from work on the project; and
- (4) the prime contractor remains ultimately responsible for the payment of predetermined minimum wages, the submission of payrolls, statements of compliance and all other Federal regulatory requirements.

b. "Specialty Items" shall be construed to be limited to work that requires highly specialized knowledge, abilities, or equipment not ordinarily available in the type of contracting organizations qualified and expected to bid or propose on the contract as a whole and in general are to be limited to minor components of the overall contract. 23 CFR 635.102.

2. Pursuant to 23 CFR 635.116(a), the contract amount upon which the requirements set forth in paragraph (1) of Section VI is computed includes the cost of material and manufactured products which are to be purchased or produced by the contractor under the contract provisions.

3. Pursuant to 23 CFR 635.116(c), the contractor shall furnish (a) a competent superintendent or supervisor who is employed by the firm, has full authority to direct performance of the work in accordance with the contract requirements, and is in charge of all construction operations (regardless of who performs the work) and (b) such other of its own organizational resources (supervision, management, and engineering services) as the contracting officer determines is necessary to assure the performance of the contract.

4. No portion of the contract shall be sublet, assigned or otherwise disposed of except with the written consent of the contracting officer, or authorized representative, and such consent when given shall not be construed to relieve the contractor of any responsibility for the fulfillment of the contract. Written consent will be given only after the contracting agency has assured that each subcontract is evidenced in writing and that it contains all pertinent provisions and requirements of the prime contract. (based on long-standing interpretation of 23 CFR 635.116).

5. The 30-percent self-performance requirement of paragraph (1) is not applicable to design-build contracts; however, contracting agencies may establish their own self-performance requirements. 23 CFR 635.116(d).

VII. SAFETY: ACCIDENT PREVENTION

This provision is applicable to all Federal-aid construction contracts and to all related subcontracts.

- 1. In the performance of this contract the contractor shall comply with all applicable Federal, State, and local laws governing safety, health, and sanitation (23 CFR Part 635). The contractor shall provide all safeguards, safety devices and protective equipment and take any other needed actions as it determines, or as the contracting officer may determine, to be reasonably necessary to protect the life and health of employees on the job and the safety of the public and to protect property in connection with the performance of the work covered by the contract. 23 CFR 635.108.
- 2. It is a condition of this contract, and shall be made a condition of each subcontract, which the contractor enters into pursuant to this contract, that the contractor and any subcontractor shall not permit any employee, in performance of the contract, to work in surroundings or under conditions which are unsanitary, hazardous or dangerous to his/her health or safety, as determined under construction safety and

health standards (29 CFR Part 1926) promulgated by the Secretary of Labor, in accordance with Section 107 of the Contract Work Hours and Safety Standards Act (40 U.S.C. 3704). 29 CFR 1926.10.

- 3. Pursuant to 29 CFR 1926.3, it is a condition of this contract that the Secretary of Labor or authorized representative thereof, shall have right of entry to any site of contract performance to inspect or investigate the matter of compliance with the construction safety and health standards and to carry out the duties of the Secretary under Section 107 of the Contract Work Hours and Safety Standards Act (40 U.S.C. 3704).

VIII. FALSE STATEMENTS CONCERNING HIGHWAY PROJECTS

This provision is applicable to all Federal-aid construction contracts and to all related subcontracts.

In order to assure high quality and durable construction in conformity with approved plans and specifications and a high degree of reliability on statements and representations made by engineers, contractors, suppliers, and workers on Federal-aid highway projects, it is essential that all persons concerned with the project perform their functions as carefully, thoroughly, and honestly as possible. Willful falsification, distortion, or misrepresentation with respect to any facts related to the project is a violation of Federal law. To prevent any misunderstanding regarding the seriousness of these and similar acts, Form FHWA-1022 shall be posted on each Federal-aid highway project (23 CFR Part 635) in one or more places where it is readily available to all persons concerned with the project:

18 U.S.C. 1020 reads as follows:

"Whoever, being an officer, agent, or employee of the United States, or of any State or Territory, or whoever, whether a person, association, firm, or corporation, knowingly makes any false statement, false representation, or false report as to the character, quality, quantity, or cost of the material used or to be used, or the quantity or quality of the work performed or to be performed, or the cost thereof in connection with the submission of plans, maps, specifications, contracts, or costs of construction on any highway or related project submitted for approval to the Secretary of Transportation; or

Whoever knowingly makes any false statement, false representation, false report or false claim with respect to the character, quality, quantity, or cost of any work performed or to be performed, or materials furnished or to be furnished, in connection with the construction of any highway or related project approved by the Secretary of Transportation; or

Whoever knowingly makes any false statement or false representation as to material fact in any statement, certificate, or report submitted pursuant to provisions of the Federal-aid Roads Act approved July 11, 1916, (39 Stat. 355), as amended and supplemented;

Shall be fined under this title or imprisoned not more than 5 years or both."

IX. IMPLEMENTATION OF CLEAN AIR ACT AND FEDERAL WATER POLLUTION CONTROL ACT (42 U.S.C. 7606; 2 CFR 200.88; EO 11738)

This provision is applicable to all Federal-aid construction contracts in excess of \$150,000 and to all related subcontracts. 48 CFR 2.101; 2 CFR 200.327.

By submission of this bid/proposal or the execution of this contract or subcontract, as appropriate, the bidder, proposer, Federal-aid construction contractor, subcontractor, supplier, or vendor agrees to comply with all applicable standards, orders or regulations issued pursuant to the Clean Air Act (42 U.S.C. 7401-7671q) and the Federal Water Pollution Control Act, as amended (33 U.S.C. 1251-1387). Violations must be reported to the Federal Highway Administration and the Regional Office of the Environmental Protection Agency. 2 CFR Part 200, Appendix II.

The contractor agrees to include or cause to be included the requirements of this Section in every subcontract, and further agrees to take such action as the contracting agency may direct as a means of enforcing such requirements. 2 CFR 200.327.

X. CERTIFICATION REGARDING DEBARMENT, SUSPENSION, INELIGIBILITY AND VOLUNTARY EXCLUSION

This provision is applicable to all Federal-aid construction contracts, design-build contracts, subcontracts, lower-tier subcontracts, purchase orders, lease agreements, consultant contracts or any other covered transaction requiring FHWA approval or that is estimated to cost \$25,000 or more – as defined in 2 CFR Parts 180 and 1200. 2 CFR 180.220 and 1200.220.

1. Instructions for Certification – First Tier Participants:

a. By signing and submitting this proposal, the prospective first tier participant is providing the certification set out below.

b. The inability of a person to provide the certification set out below will not necessarily result in denial of participation in this covered transaction. The prospective first tier participant shall submit an explanation of why it cannot provide the certification set out below. The certification or explanation will be considered in connection with the department or agency's determination whether to enter into this transaction. However, failure of the prospective first tier participant to furnish a certification or an explanation shall disqualify such a person from participation in this transaction. 2 CFR 180.320.

c. The certification in this clause is a material representation of fact upon which reliance was placed when the contracting agency determined to enter into this transaction. If it is later determined that the prospective participant knowingly rendered an erroneous certification, in addition to other remedies available to the Federal Government, the contracting agency may terminate this transaction for cause of default. 2 CFR 180.325.

d. The prospective first tier participant shall provide immediate written notice to the contracting agency to whom this proposal is submitted if any time the prospective first tier participant learns that its certification was erroneous when submitted or has become erroneous by reason of changed circumstances. 2 CFR 180.345 and 180.350.

e. The terms "covered transaction," "debarred," "suspended," "ineligible," "participant," "person," "principal," and "voluntarily excluded," as used in this clause, are defined in 2 CFR Parts 180, Subpart I, 180.900-180.1020, and 1200. "First Tier Covered Transactions" refers to any covered transaction between a recipient or subrecipient of Federal funds and a participant (such as the prime or general contract). "Lower Tier Covered Transactions" refers to any covered transaction under a First Tier Covered Transaction (such as subcontracts). "First Tier Participant" refers to the participant who has entered into a covered transaction with a recipient or subrecipient of Federal funds (such as the prime or general contractor). "Lower Tier Participant" refers any participant who has entered into a covered transaction with a First Tier Participant or other Lower Tier Participants (such as subcontractors and suppliers).

f. The prospective first tier participant agrees by submitting this proposal that, should the proposed covered transaction be entered into, it shall not knowingly enter into any lower tier covered transaction with a person who is debarred, suspended, declared ineligible, or voluntarily excluded from participation in this covered transaction, unless authorized by the department or agency entering into this transaction. 2 CFR 180.330.

g. The prospective first tier participant further agrees by submitting this proposal that it will include the clause titled "Certification Regarding Debarment, Suspension, Ineligibility and Voluntary Exclusion-Lower Tier Covered Transactions," provided by the department or contracting agency, entering into this covered transaction, without modification, in all lower tier covered transactions and in all solicitations for lower tier covered transactions exceeding the \$25,000 threshold. 2 CFR 180.220 and 180.300.

h. A participant in a covered transaction may rely upon a certification of a prospective participant in a lower tier covered transaction that is not debarred, suspended, ineligible, or voluntarily excluded from the covered transaction, unless it knows that the certification is erroneous. 2 CFR 180.300; 180.320, and 180.325. A participant is responsible for ensuring that its principals are not suspended, debarred, or otherwise ineligible to participate in covered transactions. 2 CFR 180.335. To verify the eligibility of its principals, as well as the eligibility of any lower tier prospective participants, each participant may, but is not required to, check the System for Award Management website (<https://www.sam.gov>). 2 CFR 180.300, 180.320, and 180.325.

i. Nothing contained in the foregoing shall be construed to require the establishment of a system of records in order to render in good faith the certification required by this clause. The knowledge and information of the prospective participant is not required to exceed that which is normally possessed by a prudent person in the ordinary course of business dealings.

j. Except for transactions authorized under paragraph (f) of these instructions, if a participant in a covered transaction knowingly enters into a lower tier covered transaction with a person who is suspended, debarred, ineligible, or voluntarily excluded from participation in this transaction, in addition to other remedies available to the Federal Government, the department or agency may terminate this transaction for cause or default. 2 CFR 180.325.

2. Certification Regarding Debarment, Suspension, Ineligibility and Voluntary Exclusion – First Tier Participants:

a. The prospective first tier participant certifies to the best of its knowledge and belief, that it and its principals:

(1) Are not presently debarred, suspended, proposed for debarment, declared ineligible, or voluntarily excluded from participating in covered transactions by any Federal department or agency, 2 CFR 180.335;.

(2) Have not within a three-year period preceding this proposal been convicted of or had a civil judgment rendered against them for commission of fraud or a criminal offense in connection with obtaining, attempting to obtain, or performing a public (Federal, State, or local) transaction or contract under a public transaction; violation of Federal or State antitrust statutes or commission of embezzlement, theft, forgery, bribery, falsification or destruction of records, making false statements, or receiving stolen property, 2 CFR 180.800;

(3) Are not presently indicted for or otherwise criminally or civilly charged by a governmental entity (Federal, State or local) with commission of any of the offenses enumerated in paragraph (a)(2) of this certification, 2 CFR 180.700 and 180.800; and

(4) Have not within a three-year period preceding this application/proposal had one or more public transactions (Federal, State or local) terminated for cause or default. 2 CFR 180.335(d).

(5) Are not a corporation that has been convicted of a felony violation under any Federal law within the two-year period preceding this proposal (USDOT Order 4200.6 implementing appropriations act requirements); and

(6) Are not a corporation with any unpaid Federal tax liability that has been assessed, for which all judicial and administrative remedies have been exhausted, or have lapsed, and that is not being paid in a timely manner pursuant to an agreement with the authority responsible for collecting the tax liability (USDOT Order 4200.6 implementing appropriations act requirements).

b. Where the prospective participant is unable to certify to any of the statements in this certification, such prospective participant should attach an explanation to this proposal. 2 CFR 180.335 and 180.340.

* * * * *

3. Instructions for Certification - Lower Tier Participants:

(Applicable to all subcontracts, purchase orders, and other lower tier transactions requiring prior FHWA approval or estimated to cost \$25,000 or more - 2 CFR Parts 180 and 1200). 2 CFR 180.220 and 1200.220.

a. By signing and submitting this proposal, the prospective lower tier participant is providing the certification set out below.

b. The certification in this clause is a material representation of fact upon which reliance was placed when this transaction was entered into. If it is later determined that the prospective lower tier participant knowingly rendered an erroneous certification, in addition to other remedies available to the Federal Government, the department, or agency with which

this transaction originated may pursue available remedies, including suspension and/or debarment.

c. The prospective lower tier participant shall provide immediate written notice to the person to which this proposal is submitted if at any time the prospective lower tier participant learns that its certification was erroneous by reason of changed circumstances. 2 CFR 180.365.

d. The terms "covered transaction," "debarred," "suspended," "ineligible," "participant," "person," "principal," and "voluntarily excluded," as used in this clause, are defined in 2 CFR Parts 180, Subpart I, 180.900 – 180.1020, and 1200. You may contact the person to which this proposal is submitted for assistance in obtaining a copy of those regulations. "First Tier Covered Transactions" refers to any covered transaction between a recipient or subrecipient of Federal funds and a participant (such as the prime or general contract). "Lower Tier Covered Transactions" refers to any covered transaction under a First Tier Covered Transaction (such as subcontracts). "First Tier Participant" refers to the participant who has entered into a covered transaction with a recipient or subrecipient of Federal funds (such as the prime or general contractor). "Lower Tier Participant" refers any participant who has entered into a covered transaction with a First Tier Participant or other Lower Tier Participants (such as subcontractors and suppliers).

e. The prospective lower tier participant agrees by submitting this proposal that, should the proposed covered transaction be entered into, it shall not knowingly enter into any lower tier covered transaction with a person who is debarred, suspended, declared ineligible, or voluntarily excluded from participation in this covered transaction, unless authorized by the department or agency with which this transaction originated. 2 CFR 1200.220 and 1200.332.

f. The prospective lower tier participant further agrees by submitting this proposal that it will include this clause titled "Certification Regarding Debarment, Suspension, Ineligibility and Voluntary Exclusion-Lower Tier Covered Transaction," without modification, in all lower tier covered transactions and in all solicitations for lower tier covered transactions exceeding the \$25,000 threshold. 2 CFR 180.220 and 1200.220.

g. A participant in a covered transaction may rely upon a certification of a prospective participant in a lower tier covered transaction that is not debarred, suspended, ineligible, or voluntarily excluded from the covered transaction, unless it knows that the certification is erroneous. A participant is responsible for ensuring that its principals are not suspended, debarred, or otherwise ineligible to participate in covered transactions. To verify the eligibility of its principals, as well as the eligibility of any lower tier prospective participants, each participant may, but is not required to, check the System for Award Management website (<https://www.sam.gov>), which is compiled by the General Services Administration. 2 CFR 180.300, 180.320, 180.330, and 180.335.

h. Nothing contained in the foregoing shall be construed to require establishment of a system of records in order to render in good faith the certification required by this clause. The knowledge and information of participant is not required to exceed that which is normally possessed by a prudent person in the ordinary course of business dealings.

i. Except for transactions authorized under paragraph e of these instructions, if a participant in a covered transaction knowingly enters into a lower tier covered transaction with a person who is suspended, debarred, ineligible, or voluntarily

excluded from participation in this transaction, in addition to other remedies available to the Federal Government, the department or agency with which this transaction originated may pursue available remedies, including suspension and/or debarment. 2 CFR 180.325.

* * * * *

4. Certification Regarding Debarment, Suspension, Ineligibility and Voluntary Exclusion--Lower Tier Participants:

a. The prospective lower tier participant certifies, by submission of this proposal, that neither it nor its principals:

(1) is presently debarred, suspended, proposed for debarment, declared ineligible, or voluntarily excluded from participating in covered transactions by any Federal department or agency, 2 CFR 180.355;

(2) is a corporation that has been convicted of a felony violation under any Federal law within the two-year period preceding this proposal (USDOT Order 4200.6 implementing appropriations act requirements); and

(3) is a corporation with any unpaid Federal tax liability that has been assessed, for which all judicial and administrative remedies have been exhausted, or have lapsed, and that is not being paid in a timely manner pursuant to an agreement with the authority responsible for collecting the tax liability. (USDOT Order 4200.6 implementing appropriations act requirements)

b. Where the prospective lower tier participant is unable to certify to any of the statements in this certification, such prospective participant should attach an explanation to this proposal.

* * * * *

XI. CERTIFICATION REGARDING USE OF CONTRACT FUNDS FOR LOBBYING

This provision is applicable to all Federal-aid construction contracts and to all related subcontracts which exceed \$100,000. 49 CFR Part 20, App. A.

1. The prospective participant certifies, by signing and submitting this bid or proposal, to the best of his or her knowledge and belief, that:

a. No Federal appropriated funds have been paid or will be paid, by or on behalf of the undersigned, to any person for influencing or attempting to influence an officer or employee of any Federal agency, a Member of Congress, an officer or employee of Congress, or an employee of a Member of Congress in connection with the awarding of any Federal contract, the making of any Federal grant, the making of any Federal loan, the entering into of any cooperative agreement, and the extension, continuation, renewal, amendment, or modification of any Federal contract, grant, loan, or cooperative agreement.

b. If any funds other than Federal appropriated funds have been paid or will be paid to any person for influencing or attempting to influence an officer or employee of any Federal agency, a Member of Congress, an officer or employee of Congress, or an employee of a Member of Congress in connection with this Federal contract, grant, loan, or

cooperative agreement, the undersigned shall complete and submit Standard Form-LLL, "Disclosure Form to Report Lobbying," in accordance with its instructions.

2. This certification is a material representation of fact upon which reliance was placed when this transaction was made or entered into. Submission of this certification is a prerequisite for making or entering into this transaction imposed by 31 U.S.C. 1352. Any person who fails to file the required certification shall be subject to a civil penalty of not less than \$10,000 and not more than \$100,000 for each such failure.

3. The prospective participant also agrees by submitting its bid or proposal that the participant shall require that the language of this certification be included in all lower tier subcontracts, which exceed \$100,000 and that all such recipients shall certify and disclose accordingly.

XII. USE OF UNITED STATES-FLAG VESSELS:

This provision is applicable to all Federal-aid construction contracts, design-build contracts, subcontracts, lower-tier subcontracts, purchase orders, lease agreements, or any other covered transaction. 46 CFR Part 381.

This requirement applies to material or equipment that is acquired for a specific Federal-aid highway project. 46 CFR 381.7. It is not applicable to goods or materials that come into inventories independent of an FHWA funded-contract.

When oceanic shipments (or shipments across the Great Lakes) are necessary for materials or equipment acquired for a specific Federal-aid construction project, the bidder, proposer, contractor, subcontractor, or vendor agrees:

1. To utilize privately owned United States-flag commercial vessels to ship at least 50 percent of the gross tonnage (computed separately for dry bulk carriers, dry cargo liners, and tankers) involved, whenever shipping any equipment, material, or commodities pursuant to this contract, to the extent such vessels are available at fair and reasonable rates for United States-flag commercial vessels. 46 CFR 381.7.

2. To furnish within 20 days following the date of loading for shipments originating within the United States or within 30 working days following the date of loading for shipments originating outside the United States, a legible copy of a rated, 'on-board' commercial ocean bill-of-lading in English for each shipment of cargo described in paragraph (b)(1) of this section to both the Contracting Officer (through the prime contractor in the case of subcontractor bills-of-lading) and to the Office of Cargo and Commercial Sealift (MAR-620), Maritime Administration, Washington, DC 20590. (MARAD requires copies of the ocean carrier's (master) bills of lading, certified onboard, dated, with rates and charges. These bills of lading may contain business sensitive information and therefore may be submitted directly to MARAD by the Ocean Transportation Intermediary on behalf of the contractor). 46 CFR 381.7.

ATTACHMENT A - EMPLOYMENT AND MATERIALS PREFERENCE FOR APPALACHIAN DEVELOPMENT HIGHWAY SYSTEM OR APPALACHIAN LOCAL ACCESS ROAD CONTRACTS (23 CFR 633, Subpart B, Appendix B) This provision is applicable to all Federal-aid projects funded under the Appalachian Regional Development Act of 1965.

1. During the performance of this contract, the contractor undertaking to do work which is, or reasonably may be, done as on-site work, shall give preference to qualified persons who regularly reside in the labor area as designated by the DOL wherein the contract work is situated, or the subregion, or the Appalachian counties of the State wherein the contract work is situated, except:

a. To the extent that qualified persons regularly residing in the area are not available.

b. For the reasonable needs of the contractor to employ supervisory or specially experienced personnel necessary to assure an efficient execution of the contract work.

c. For the obligation of the contractor to offer employment to present or former employees as the result of a lawful collective bargaining contract, provided that the number of nonresident persons employed under this subparagraph (1c) shall not exceed 20 percent of the total number of employees employed by the contractor on the contract work, except as provided in subparagraph (4) below.

2. The contractor shall place a job order with the State Employment Service indicating (a) the classifications of the laborers, mechanics and other employees required to perform the contract work, (b) the number of employees required in each classification, (c) the date on which the participant estimates such employees will be required, and (d) any other pertinent information required by the State Employment Service to complete the job order form. The job order may be placed with the State Employment Service in writing or by telephone. If during the course of the contract work, the information submitted by the contractor in the original job order is substantially modified, the participant shall promptly notify the State Employment Service.

3. The contractor shall give full consideration to all qualified job applicants referred to him by the State Employment Service. The contractor is not required to grant employment to any job applicants who, in his opinion, are not qualified to perform the classification of work required.

4. If, within one week following the placing of a job order by the contractor with the State Employment Service, the State Employment Service is unable to refer any qualified job applicants to the contractor, or less than the number requested, the State Employment Service will forward a certificate to the contractor

indicating the unavailability of applicants. Such certificate shall be made a part of the contractor's permanent project records. Upon receipt of this certificate, the contractor may employ persons who do not normally reside in the labor area to fill positions covered by the certificate, notwithstanding the provisions of subparagraph (1c) above.

5. The provisions of 23 CFR 633.207(e) allow the contracting agency to provide a contractual preference for the use of mineral resource materials native to the Appalachian region.

6. The contractor shall include the provisions of Sections 1 through 4 of this Attachment A in every subcontract for work which is, or reasonably may be, done as on-site work.

Appendix A of Department of Transportation Order 1050.2A

“During the performance of this contract, the contractor, for itself, its assignees, and successors in interest (hereinafter referred to as the "contractor") agrees as follows:

1. Compliance with Regulations: The contractor (hereinafter includes consultants) will comply with the Acts and the Regulations relative to Non-discrimination in Federally-assisted programs of the U.S. Department of Transportation, Federal Highway Administration (FHWA), as they may be amended from time to time, which are herein incorporated by reference and made a part of this contract.

2. Non-discrimination: The contractor, with regard to the work performed by it during the contract, will not discriminate on the grounds of race, color, or national origin in the selection and retention of subcontractors, including procurements of materials and leases of equipment. The contractor will not participate directly or indirectly in the discrimination prohibited by the Acts and the Regulations, including employment practices when the contract covers any activity, project, or program set forth in Appendix B of 49 C.F.R. Part 21.

3. Solicitations for Subcontracts, Including Procurements of Materials and Equipment: In all solicitations, either by competitive bidding, or negotiation made by the contractor for work to be performed under a subcontract, including procurements of materials, or leases of equipment, each potential subcontractor or supplier will be notified by the contractor of the contractor's obligations under this contract and the Acts and the Regulations relative to Non-discrimination on the grounds of race, color, or national origin.

4. Information and Reports: The contractor will provide all information and reports required by the Acts, the Regulations, and directives issued pursuant thereto and will permit access to its books, records, accounts, other sources of information, and its facilities as may be determined by the Recipient or the FHWA to be pertinent to ascertain compliance with such Acts, Regulations, and instructions. Where any information required of a contractor is in the exclusive possession of another who fails or refuses to furnish the information, the contractor will so certify to the Recipient or the FHWA, as appropriate, and will set forth what efforts it has made to obtain the information.

5. Sanctions for Noncompliance: In the event of a contractor's noncompliance with the Non-discrimination provisions of this contract, the Recipient will impose such contract sanctions as it or the FHWA may determine to be appropriate, including, but not limited to:

- a. withholding payments to the contractor under the contract until the contractor complies; and/or
- b. cancelling, terminating, or suspending a contract, in whole or in part.

6. Incorporation of Provisions: The contractor will include the provisions of paragraphs one through six in every subcontract, including procurements of materials and leases of equipment, unless exempt by the Acts, the Regulations and directives issued pursuant thereto. The contractor will take action with respect to any subcontract or procurement as the Recipient or the FHWA may direct as a means of enforcing such provisions including sanctions for noncompliance. Provided, that if the contractor becomes involved in, or is threatened with litigation by a subcontractor, or supplier because of such direction, the contractor may request the Recipient to enter into any litigation to protect the interests of the Recipient. In addition, the contractor may request the United States to enter into the litigation to protect the interests of the United States.”

Appendix E of Department of Transportation Order 1050.2A

“During the performance of this contract, the contractor, for itself, its assignees, and successors in interest (hereinafter referred to as the "contractor") agrees to comply with the following non-discrimination statutes and authorities; including but not limited to:

Pertinent Non-Discrimination Authorities:

- Title VI of the Civil Rights Act of 1964 (42 U.S.C. § 2000d et seq., 78 stat. 252), (prohibits discrimination on the basis of race, color, national origin); and 49 C.F.R. Part 21.
- The Uniform Relocation Assistance and Real Property Acquisition Policies Act of 1970, (42 U.S.C. § 4601), (prohibits unfair treatment of persons displaced or whose property has been acquired because of Federal or Federal-aid programs and projects);
- Federal-Aid Highway Act of 1973, (23 U.S.C. § 324 et seq.), (prohibits discrimination on the basis of sex);
- Section 504 of the Rehabilitation Act of 1973, (29 U.S.C. § 794 et seq.), as amended, (prohibits discrimination on the basis of disability); and 49 C.F.R. Part 27;
- The Age Discrimination Act of 1975, as amended, (42 U.S.C. § 6101 et seq.), (prohibits discrimination on the basis of age);
- Airport and Airway Improvement Act of 1982, (49 U.S.C. § 471, Section 47123), as amended, (prohibits discrimination based on race, creed, color, national origin, or sex);
- The Civil Rights Restoration Act of 1987, (PL 100-209), (Broadened the scope, coverage and applicability of Title VI of the Civil Rights Act of 1964, The Age Discrimination Act of 1975 and Section 504 of the Rehabilitation Act of 1973, by expanding the definition of the terms "programs or activities" to include all of the programs or activities of the Federal-aid recipients, sub-recipients and contractors, whether such programs or activities are Federally funded or not);
- Titles II and III of the Americans with Disabilities Act, which prohibit discrimination on the basis of disability in the operation of public entities, public and private transportation systems, places of public accommodation, and certain testing entities (42 U.S.C. §§ 12131 – 12189) as implemented by Department of Transportation regulations at 49 C.F.R. Parts 37 and 38;
- The Federal Aviation Administration's Non-discrimination statute (49 U.S.C. § 47123) (prohibits discrimination on the basis of race, color, national origin, and sex);
- Executive Order 12898, Federal Actions to Address Environmental Justice in Minority Populations and Low-Income Populations, which ensures nondiscrimination against minority populations by discouraging programs, policies, and activities with disproportionately high and adverse human health or environmental effects on minority and low-income populations;
- Executive Order 13166, Improving Access to Services for Persons with Limited English Proficiency, and resulting agency guidance, national origin discrimination includes discrimination because of limited English proficiency (LEP). To ensure compliance with Title VI, you must take reasonable steps to ensure that LEP persons have meaningful access to your programs (70 Fed. Reg. at 74087 to 74100);
- Title IX of the Education Amendments of 1972, as amended, which prohibits you from discriminating because of sex in education programs or activities (20 U.S.C. § 1681 et seq).”

ADDITIONAL CONTRACT PROVISIONS

SUPPLEMENT TO THE WEEKLY CERTIFIED PAYROLLS

In addition to the required payroll data as enumerated in Section V, Part 2 of the Form FHWA-1273, "Required Contract Provisions, Federal-Aid Construction Contracts (Exclusive of Appalachian Contracts)", to facilitate monitoring of the Affirmative Action goals for each contract, employers are required to list, for their employees, a designation of race, ethnicity, color or national origin and Male/Female identifier on each weekly certified payroll.

For standardization, please use the following identification codes:

- i. White/Caucasian: Persons having origins in Europe, North Africa or the Middle East.
- ii. Black/African American (except Hispanic): Persons having origins in any of the Black racial groups of Africa.
- iii. Native American – American Indian or Alaskan Native: Persons having origins in any of the original peoples of North America and who maintain their culture through a tribe or community.
- iv. Hawaiian or other Pacific Islander: Persons having origins in the original peoples of Hawaii or other Pacific Islands.
- v. Asian: Persons having origins in any of the peoples of the Far East, Southeast Asia, or India.
- vi. Hispanic Americans: Persons of Mexican, Puerto Rican, Cuban, Central or South American origin, or other Spanish culture or origin, regardless of race.
- vii. Two or More Races: Persons who identify with two or more designations listed above, or other persons protected from employment discrimination by EEO law, based on race, ethnicity, color or national origin, not otherwise defined.
- viii. Not Specified: Only for persons who choose not to list their race, ethnicity, color, or national origin.

ADDITIONAL CONTRACT PROVISIONS
DISADVANTAGED BUSINESS ENTERPRISE
IN FEDERAL-AID HIGHWAY CONSTRUCTION

DISADVANTAGED BUSINESS ENTERPRISE. This project is subject to Part 26, TITLE 49, Code of Federal Regulations entitled “Participation by Disadvantaged Business Enterprises in Department of Transportation Programs.”

Policy. It is the policy of the Department of Transportation that disadvantaged business enterprises as defined in 49 CFR Part 26.5 shall have the maximum opportunity to participate in the performance of contracts financed in whole or in part with Federal funds under this agreement. Consequently the DBE requirements of 49 CFR Part 26 apply to this agreement.

Obligation. (i) The recipient or its contractor agrees to ensure that disadvantaged business enterprises as defined in 49 CFR Part 26 have the maximum opportunity to participate in the performance of contracts and subcontracts financed in whole or part with Federal funds provided under this agreement. In this regard all recipients or contractors shall take all necessary and reasonable steps in accordance with 49 CFR Part 26 to ensure that disadvantaged business enterprise have the maximum opportunity to compete for and perform contracts. Recipients and their contractors shall not discriminate on the basis of race, color, national origin, sex or handicap in the award and performance of NDOT assisted contracts.

I. BIDDERS DBE AFFIRMATIVE ACTION REQUIREMENTS

- A. A bidder who intends to subcontract a portion of the work shall certify that affirmative action has been taken to seek out and consider disadvantaged business enterprises and women owned businesses as potential subcontractors.
- B. Affirmative action shall consist of seeking out disadvantaged business enterprises and women owned businesses that are potential subcontractors and actively soliciting their interest, capability and prices and documenting such action.
- C. “Socially and economically disadvantaged individual” means any person who is a citizen or lawful permanent resident of the United States and who is;
 - (a) Black (a person having origins in any of the black racial groups of Africa);
 - (b) Hispanic (a person of Spanish or Portuguese culture with origins in Mexico, South or Central America, or the Caribbean Islands, regardless of race);
 - (c) Asian American (a person having origins in any of the original peoples of the Far East, Southeast Asia, the Indian subcontinent, or the Pacific Islands);
 - (d) American Indian and Alaskan Native (a person having origins in any of the original peoples of North America); or
 - (e) A woman

- D. Bidders shall be fully informed respecting the requirements of the Regulations; particular attention is directed to the following matters:
- (a) A Disadvantaged Business Enterprise (DBE) must be a small business concern as defined pursuant to Section 3 of a U.S. Small Business Act; and 49 CFR Part 26.5
 - (b) "Disadvantaged Business" means a small business concern: (a) which is at least 51 percent owned by one or more socially and economically disadvantaged individuals, or, in the case of any publicly owned business, at least 51 percent of the stock of which is owned by one or more socially and economically disadvantaged individuals; and (b) whose management and daily business operations are controlled by one or more of the socially and economically disadvantaged individuals who own it.
- E. The Contractor shall designate and make known to the Engineer a liaison officer to administer the Contractor's disadvantaged business enterprise program.

STANDARD FEDERAL EQUAL EMPLOYMENT OPPORTUNITY CONSTRUCTION
CONTRACT SPECIFICATIONS (EXECUTIVE ORDER 11246)

1. As used in these specifications:
 - a. "Covered Area" means the geographical area described in the "Notice of Requirement for Affirmative Action to Ensure Equal Employment Opportunity (Executive Order 11246)", of these special provisions.
 - b. "Director" means Director, Office of Federal Contract Compliance Programs, United States Department of Labor, or any person to whom the Director delegates authority;
 - c. "Employer identification number" means the Federal Social Security number used on the Employer's Quarterly Federal Tax Return, U.S. Treasury Department Form 941.
 - d. "Minority" includes:
 - (i) Black (all persons having origins in any of the Black African racial groups not of Hispanic origin);
 - (ii) Hispanic (all persons of Spanish or Portuguese ancestry whose culture is rooted in South America, Central America, Mexico, Puerto Rico, Cuba, the Caribbean Islands or the Iberian Peninsula, including Portugal, regardless of race);
 - (iii) Asian and Pacific Islander (all persons having origins in any of the original peoples of the Far East, Southeast Asia, the Indian Subcontinent, or the Pacific Islands); and
 - (iv) American Indian or Alaskan Native (all persons having origins in any of the original peoples of North American and maintaining identifiable tribal affiliations through membership and participation or community identification).
2. Whenever the Contractor, or any subcontractor at any tier, subcontracts a portion of the work involving any construction trade, it shall physically include in each subcontract in excess of \$10,000 the provisions of these specifications and the Notice which contains the applicable goals for minority and female participation and which is set forth in the solicitations from which this contract resulted.
3. If the Contractor is participating (pursuant to 41 CFR 60-4.5) in a Hometown Plan approved by the U. S. Department of Labor in the covered area either individually or through an association, its affirmative action obligations on all work in the Plan area (including goals and timetables) shall be in accordance with that Plan for those trades which have unions participating in the Plan. Contractors must be able to demonstrate their participation in and compliance with the provisions of any such Hometown Plan. Each Contractor or subcontractor participating in an approved Plan is individually required to comply with its obligations under the EEO clause, and to make a good faith effort to achieve each goal under the Plan in each trade in which it has employees. The overall good faith performance by other Contractors or subcontractors toward a goal in an approved Plan does not excuse any covered contractor's or subcontractor's failure to take good faith efforts to achieve the Plan goals and timetables.
4. The Contractor shall implement the specific affirmative action standards provided in paragraphs 7a through p of these specifications. The goals set forth in the solicitation from

which this contract resulted are expressed as percentages of the total hours of employment and training of minority and female utilization the Contractor should reasonably be able to achieve in each construction trade in which it has employees in the covered area. Covered Construction contractors performing construction work in geographical areas where they do not have a Federal or federally assisted construction contract shall apply the minority and female goals established for the geographical area where the work is being performed. Goals are published periodically in the FEDERAL REGISTER in notice form, and such notices may be obtained from any Office of Federal Contract Compliance Programs office or from Federal procurement contracting officers. The Contractor is expected to make substantially uniform progress in meeting its goals in each craft during the period specified.

5. Neither the provisions of any collective bargaining agreement, nor the failure by a union with whom the Contractor has a collective bargaining agreement, to refer either minorities or women shall excuse the Contractor's obligations under these specifications, Executive Order 11246, or the regulations promulgated pursuant thereto.
6. In order for the non-working training hours of apprentices and trainees to be counted in meeting the goals, such apprentices and trainees must be employed by the Contractor during the training period, and the Contractor must have made a commitment to employ the apprentices and trainees at the completion of their training, subject to the availability of employment opportunities. Trainees must be trained pursuant to training programs approved by the U. S. Department of Labor.
7. The Contractor shall take specific affirmative actions to ensure equal employment opportunity. The evaluation of the Contractor's compliance with these specifications shall be based upon its effort to achieve maximum results from its actions. The Contractor shall document these efforts fully, and shall implement affirmative action steps at least as extensive as the following:
 - a. Ensure and maintain a working environment free of harassment, intimidation, and coercion at all sites, and in all facilities at which the Contractor's employees are assigned to work. The Contractor, where possible, will assign two or more women to each construction project. The Contractor shall specifically ensure that all foremen, superintendents, and other on-site supervisory personnel are aware of and carry out the Contractor's obligation to maintain such a working environment, with specific attention to minority or female individuals working at such sites or in such facilities.
 - b. Establish and maintain a current list of minority and female recruitment sources, provide written notification to minority and female recruitment sources and to community organizations when the Contractor or its unions have employment opportunities available, and maintain a record of the organization's responses.
 - c. Maintain a current file of the names, addresses and telephone numbers of each minority and female off-the-street applicant and minority or female referral from a union, a recruitment source or community organization and of what action was taken with respect to each such individual. If such individual was sent to the union hiring hall for referral and was not referred back to the Contractor by the union or, if referred, not employed by the Contractor, this shall be documented in the file with the reason therefore, along with whatever additional actions the Contractor may have taken.
 - d. Provide immediate written notification to the Director when the union or unions with which the Contractor has a collective bargaining agreement has not referred to the Contractor a minority person or woman sent by the Contractor, or when the Contractor has

other information that the union referral process has impeded the Contractor's efforts to meet its obligations.

- e. Develop on-the-job training opportunities and/or participate in training programs for the area which expressly include minorities and women, including upgrading programs and apprenticeship and trainee programs relevant to the Contractor's employment needs, especially those programs funded or approved by the Department of Labor. The Contractor shall provide notice of these programs to the sources compiled under 7b above.
- f. Disseminate the Contractor's EEO policy by providing notice of the policy to unions and training programs and requesting their cooperation in assisting the Contractor in meeting its EEO obligations; by including it in any policy manual and collective bargaining agreement; by publicizing it in the company newspaper, annual report, etc.; by specific review of the policy with all management personnel and with all minority and female employees at least once a year; and by posting the company EEO policy on bulletin boards accessible to all employees at each location where construction work is performed.
- g. Review, at least annually, the company's EEO policy and affirmative action obligations under these specifications with all employees having any responsibility for hiring, assignment, layoff, termination or other employment decisions including specific review of these items with on-site supervisory personnel such as Superintendents, General Foremen, etc., prior to the initiation of construction work at any job site. A written record shall be made and maintained identifying the time and place of these meetings, persons attending, subject matter discussed, and disposition of the subject matter.
- h. Disseminate the Contractor's EEO policy externally by including it in any advertising in the news media, specifically including minority and female news media, and providing written notification to and discussing the contractor's EEO policy with other contractors and subcontractors with whom the Contractor does or anticipates doing business.
- i. Direct its recruitment efforts, both oral and written, to minority, female and community organizations, to schools with minority and female students and to minority and female recruitment and training organizations serving the Contractor's recruitment area and employment needs. Not later than one month prior to the date for the acceptance of applications for apprenticeship or other training by any recruitment source, the Contractor shall send written notification to organizations such as the above, describing the openings, screening procedures, and tests to be used in the selection process.
- j. Encourage present minority and female employees to recruit other minority persons and women and, where reasonable, provide after school, summer and vacation employment to minority and female youth both on the site and in other areas of a Contractor's work force.
- k. Validate all tests and other selection requirements where there is an obligation to do so under 41 CFR Part 60-3.
- l. Conduct, at least annually, an inventory and evaluation at least of all minority and female personnel for promotional opportunities and encourage these employees to seek or to prepare for, through appropriate training, etc., such opportunities.

- m. Ensure that seniority practices, job classifications, work assignments and other personnel practices, do not have a discriminatory affect by continually monitoring all personnel and employment related activities to ensure that the EEO policy and the Contractor's obligations under these specifications are being carried out.
 - n. Ensure that all facilities and company activities are non- segregated except that separate or single-user toilet and necessary changing facilities shall be provided to assure privacy between the sexes.
 - o. Document and maintain a record of all solicitations of offers for subcontracts from minority and female construction contractors and suppliers, including circulation of solicitations to minority and female contractor associations and other business associations.
 - p. Conduct a review, at least annually, of all supervisors' adherence to and performance under the Contractor's EEO policies and affirmative action obligations.
8. Contractors are encouraged to participate in voluntary associations which assist in fulfilling one or more of their affirmative action obligations (7a through p). The efforts of a Contractor association, joint contractor-union, contractor-community, or other similar group of which the contractor is a member and participant, may be asserted as fulfilling any one or more of its obligations under 7a through p of these specifications provided that the contractor actively participates in the group, makes every effort to assure that the group has a positive impact on the employment of minorities and women in the industry, ensures that the concrete benefits of the program are reflected in the contractor's minority and female work force participation, makes a good faith effort to meet its individual goals and timetables, and can provide access to documentation which demonstrates the effectiveness of actions taken on behalf of the contractor. The obligation to comply, however, is the contractor's and failure of such a group to fulfill an obligation shall not be a defense for the contractor's non-compliance.
9. A single goal for minorities and a separate single goal for women have been established. The contractor, however, is required to provide equal employment opportunity and to take affirmative action for all minority groups, both male and female, and all women, both minority and non-minority. Consequently, the contractor may be in violation of the Executive Order if a particular group is employed in a substantially disparate manner (for example, even though the contractor has achieved its goals for women generally, the contractor may be in violation of the Executive Order if a specific minority group of women is underutilized).
10. The contractor shall not use the goals and timetables or affirmative action standards to discriminate against any person because of race, color, religion, sex, or national origin.
11. The contractor shall not enter into any subcontract with any person or firm debarred from Government contracts pursuant to Executive Order 11246.
12. The contractor shall carry out such sanctions and penalties for violation of these specifications and of the Equal Opportunity Clause, including suspension, termination and cancellation of existing subcontracts as may be imposed or ordered pursuant to Executive Order 11246, as amended, and its implementing regulations, by the Office of Federal Contract Compliance Programs. Any contractor who fails to carry out such sanctions and penalties shall be in violation of these specifications and Executive Order 11246, as amended.
13. The contractor, in fulfilling its obligations under these specifications, shall implement specific affirmative action steps, at least as extensive as those standards prescribed in paragraph 7 of

these specifications, so as to achieve maximum results from its efforts to ensure equal employment opportunity. If the contractor fails to comply with the requirements of the Executive Order, the implementing regulations, or these specifications, the Director shall proceed in accordance with 41 CFR 60-4.8.

14. The contractor shall designate a responsible official to monitor all employment related activity to ensure that the company EEO policy is being carried out, to submit reports relating to the provisions hereof as may be required by the Government and to keep records. Records shall at least include for each employee the name, address, telephone numbers, construction trade, union affiliation if any, employee identification number when assigned, social security number, race, sex, status (e.g., mechanic, apprentice, trainee, helper, or laborer), dates of changes in status, hours worked per week in the indicated trade, rate of pay, and locations at which the work was performed. Records shall be maintained in an easily understandable and retrievable form; however, to the degree that existing records satisfy this requirement, contractors shall not be required to maintain separate records.
15. Nothing herein provided shall be construed as a limitation upon the application of other laws which establish different standards of compliance or upon the application of requirement for the hiring of local or other area residents (e.g., those under the Public Works Employment Act of 1977 and the Community Development Block Grant Program).
16. All such records must be retained for a period of three years following completion of the contract work and shall be available at reasonable times and places for inspection by authorized representatives of the State Department of Transportation and the Federal Highway Administration.
17. FHWA 1409 (Federal-Aid Highway Construction Contractors Semiannual report).

(INSTRUCTIONS: This report is to be completed by the Contractor semiannually for each individual employed on this contract (including any subcontracts under it) who has received training during the reporting period under the training special provisions (Attachment 2 FHPM 6-4-1.2). The report is to be submitted by the 20th of the month following the reporting period (July 20 and January 20). The original of this report is to be furnished to the trainee and two copies submitted to the Nevada Department of Transportation.)
18. Required Reports: Form PR-1391 (Federal-Aid Highway Construction Contractors Annual EEO Reports).

This report should be submitted to the Nevada Department of Transportation by each Contractor and covered subcontractor for the month of July. Subcontractors should report contract and employment data pertaining to their subcontract work only. The staffing figures to be reported under employment data should represent the project work force on board in whole or in part for the last payroll period preceding the end of the month.

The staffing figures to be reported in Table A should include journey-level men and women, apprentices, and on-the-job trainees. Staffing figures to be reported in Tables B and C should only include apprentices and on-the-job trainees as indicated.

**AFFIDAVIT REQUIRED UNDER 23 USC SECTION 112(c)
AND 2 CFR PARTS 180 AND 1200 – SUSPENSION OR DEBARMENT**

STATE OF _____ }
COUNTY OF _____ } SS

I, _____ (Name of party signing this
affidavit and the Proposal Form) _____ (title).

being duly sworn do depose and say: That _____ (name of
person, firm, association, or corporation) has not, either directly or indirectly, entered into agreement,
participated in any collusion, or otherwise taken any action in restraint of free competitive bidding in
connection with this contract; and further that, except as noted below to the best of knowledge, the
above named and its principals:

- (a) Are not presently debarred, suspended, proposed for debarment, declared ineligible, or voluntarily excluded from covered transactions by any Federal department or agency;
- (b) Have not within a three-year period preceding this proposal been convicted of or had a civil judgement rendered against them for commission of fraud or a criminal offense in connection with obtaining, attempting to obtain, or performing a public or private agreement or transaction; violation of Federal or State antitrust statutes, including those proscribing price fixing between competitors, allocation of customers between competitors, and bid rigging; commission of embezzlement, theft, forgery, bribery, falsification or destruction of records, making false statements, tax evasion, receiving stolen property, making false claims, or obstruction of justice; commission of any other offense indicating a lack of business integrity or business honesty that seriously and directly affects your present responsibility;
- (c) Are not presently indicted for or otherwise criminally or civilly charged by a government entity (Federal, State or local) with commission of any of the offenses enumerated in paragraph (b) of this certification; and
- (d) Have not within a three-year period preceding this application/proposal had one or more public transactions (Federal, State or local) terminated for cause or default.

(Insert Exceptions, attach additional sheets)

The above exceptions will not necessarily result in denial of award, but will be considered in determining bidder responsibility and whether or not the City will enter into contract with the party. For any exception noted, indicate on an attached sheet to whom it applies, initiating agency, and dates of action. Providing false information may result in criminal prosecution or administrative sanctions. The failure to furnish this affidavit and required exceptions if any shall disqualify the party.

Signature

Title

Sworn to before me this _____ day of _____, 20____

(SEAL)

Notary Public, Judge or other Official

CERTIFICATION REQUIRED BY SECTION 1352 OF TITLE 31, UNITED STATES CODE
RESTRICTIONS OF LOBBYING USING APPROPRIATED FEDERAL FUNDS

The undersigned certifies, to the best of his or her knowledge and belief that:

(1) No Federal appropriate funds have been paid or will be paid, by or on behalf of the undersigned, to any person for influencing or attempting to influence an officer or employee of any agency, a Member of Congress, an officer or employee of Congress, or an employee of a Member of Congress in connection with the awarding of any Federal loan, the entering into of any cooperative agreement, and the extension, continuation, renewal, amendment, or modification of any Federal contract, grant, loan, or cooperative agreement.

(2) If any funds other than Federal appropriated funds have been paid or will be paid to any person for influencing or attempting to influence an officer or employee of any agency, a Member of Congress, an officer or employee of Congress, or an employee of a Member of Congress in connection with this Federal contract, grant, loan, or cooperative agreement, the undersigned shall complete and submit Standard Form-LLL, "Disclosure Form to Report Lobbying," in accordance with its instructions.

(3) The undersigned shall require that the language of this certification be included in the award documents for all subawards at all tiers (including subcontracts, subgrants, and contracts under grants, loans, and cooperative agreements) and that all subrecipients shall certify and disclose accordingly.

This certification is a material representation of fact upon which reliance was placed when this transaction was made or entered into. Submission of this certification is a prerequisite for making or entering into this transaction imposed by section 1352, title 31, U.S. Code. Any person who fails to file the required certification shall be subject to a civil penalty of not less than \$10,000 and not more than \$100,000 for each such failure.

Name (please type or print)

Signature

Title

INSTRUCTIONS FOR COMPLETION OF SF-LLL, DISCLOSURE OF LOBBYING ACTIVITIES

This disclosure form shall be completed by the reporting entity, whether subawardee or prime Federal recipient, at the initiation or receipt of a covered Federal action, or material change to a previous filing, pursuant to title 31 U.S.C. section 1352. The filing of a form is required for each payment or agreement to make payment to any lobbying entity for influencing or attempting to influence an officer or employee of any agency, a Member of Congress, an officer or employee of Congress, or an employee of a Member of Congress in connection with a covered Federal action. Use the SF-LLL-A Continuation Sheet for additional information if the space on the form is inadequate. Complete all items that apply for both the initial filing and material change report. Refer to the implementing guidance published by the Office of Management and Budget for additional information.

1. Identify the type of covered Federal action for which lobbying activity in and/or has been secured to influence the outcome of a covered Federal action.
2. Identify the status of the covered Federal action.
3. Identify the appropriate classification of this report. If this is a follow up report caused by a material change to the information previously reported, enter the year and quarter in which the change occurred. Enter the date of the last previously submitted report by this reporting entity for this covered Federal action.
4. Enter the full name, address, city, state and zip code of the reporting entity. Include Congressional District, if known. Check the appropriate classification of the reporting entity that designates if it is, or expects to be, a prime or subaward recipient. Identify the tier of the subawardee, e.g., the first subawardee of the prime is the 1st tier. Subawards include but are not limited to subcontracts, subgrants and contract awards under grants.
5. If the organization filing the report in item 4 checks "Subawardee", then enter the full name, address, city, state and zip code of the prime Federal recipient. Include Congressional District, if known.
6. Enter the name of the Federal agency making the award or loan commitment. Include at least one organizational level below agency name, if known. For example, Department of Transportation, United States Coast Guard.
7. Enter the Federal program name or description for the covered Federal action (item 1). If known, enter the full Catalog of Federal Domestic Assistance (CFDA) number for grants, cooperative agreements, loans, and loan commitments.
8. Enter the most appropriate Federal identifying number available for the Federal action identified in item 1 (e.g., Request for Proposal (RFP) number; Invitation for Bid (IFB) number; grant announcement number; the contract, grant, or loan award number; the application/proposal control number assigned by the Federal agency). Include prefixes, e.g., "RFP-DE-90-001."
9. For a covered Federal action where there has been an award or loan commitment by the Federal agency, enter the Federal amount of the award/loan commitment for the prime entity identified in item 4 or 5.
10. (a) Enter the full name, address, city, state and zip code of the lobbying entity engaged by the reporting entity identified in item 4 to influence the covered Federal action.
(b) Enter the full names of the individual(s) performing services, and include full address if different from 10 (a). Enter Last Name, first Name, and Middle Initial (MI).
11. Enter the amount of compensation paid or reasonably expected to be paid by the reporting entity (item 4) to the lobbying entity (item 10). Indicate whether the payment has been made (actual) or will be made (planned). Check all boxes that apply. If this is a material change report, enter the cumulative amount of payment made or planned to be made.
12. Check the appropriate box(es). Check all boxes that apply. If payment is made through an in-kind contribution, specify the nature and value of the in-kind payment.
13. Check the appropriate box(es). Check all boxes that apply. If other, specify nature.
14. Provide a specific and detailed description of the services that the lobbyist has performed, or will be expected to perform, and the date(s) of any services rendered. Include all preparatory and related activity, not just time spent in actual contact with Federal officials. Identify the Federal officials. Identify the Federal official(s) or employee(s) contacted or the officer(s), employee(s), or Member(s) of Congress that were contacted.
15. Check whether or not a SF-LL-A Continuation Sheet(s) is attached.
16. The certifying official shall sign and date the form, print his/her name, title, and telephone number.

Public reporting burden for this collection of information is estimated to average 30 minutes per response, including time for reviewing instructions, searching existing data sources, gathering and maintaining the data needed, and completing and reviewing the collection of information. Send comments regarding the burden estimate or any other aspect of this collection of information, including suggestions for reducing this burden, to the Office of Management and Budget, Paperwork Reduction Project (0348-0046), Washington, D.C. 20503.



State of Nevada
Department of Transportation
Contract Compliance Section
1263 South Stewart Street
Carson City, Nevada 89712
Phone: (775) 888-7497
Fax: (775) 888-7235

MEMORANDUM

CONTRACT COMPLIANCE SECTION

July 10, 2015

To: All Resident Engineers and Consultants
From: Tracy Bacon, Compliance/Audit Investigator II
Subject: Federal-Aid Highway Construction Contractors Annual EEO Report
(Form FHWA-1391)

Contractors and Subcontractors on all *Federal-Aid* projects **must** submit an annual report **for the last full payroll period preceding the end of July 2015** indicating the number of minority, women and non-minority employees currently engaged in each work classification required by the contract work.

This information is to be reported on **Form FHWA-1391** by the contractors and subcontractors **through LCPtracker no later than August 14, 2015.**

As a reminder, every contractor and subcontractor must be reported. Therefore, even if a contractor or subcontractor performing work on a Federal-Aid project had a "Non Performing" week during the reporting period, the Form FHWA-1391 **must** still be submitted. Failure to provide this information may result in the retention of progress payments. If you have any questions, please contact the External Civil Rights and Contract Compliance Office at 775-888-7497.

:tb

FEDERAL-AID HIGHWAY CONSTRUCTION CONTRACTORS ANNUAL EEO REPORT

1. MARK APPROPRIATE BLOCK <input type="checkbox"/> Contractor <input type="checkbox"/> Subcontractor	2. COMPANY NAME, CITY, STATE:	3. PROJECT NUMBER:	4. DOLLAR AMOUNT OF CONTRACT:	5. PROJECT LOCATION: (County and State)
--	-------------------------------	--------------------	-------------------------------	---

This collection of information is required by law and regulation 23 U.S.C. 140a and 23 CFR Part 230. The OMB control number for this collection is 2125-0019 expiring in March, 2016.

6. WORKFORCE ON FEDERAL-AID AND CONSTRUCTION SITE(S) DURING LAST FULL PAY PERIOD ENDING IN JULY 20__ (INSERT YEAR)

JOB CATEGORIES	TABLE A																TABLE B					
	TOTAL EMPLOYED		TOTAL RACIAL/ ETHNIC MINORITY		BLACK or AFRICAN AMERICAN		HISPANIC OR LATINO		AMERICAN INDIAN OR ALASKA NATIVE		ASIAN		NATIVE HAWAIIAN OR OTHER PACIFIC ISLANDER		TWO OR MORE RACES		WHITE		APPRENTICES		ON THE JOB TRAINEES	
	M	F	M	F	M	F	M	F	M	F	M	F	M	F	M	F	M	F	M	F	M	F
OFFICIALS	0	0	0	0																		
SUPERVISORS	0	0	0	0																		
FOREMEN/WOMEN	0	0	0	0																		
CLERICAL	0	0	0	0																		
EQUIPMENT OPERATORS	0	0	0	0																		
MECHANICS	0	0	0	0																		
TRUCK DRIVERS	0	0	0	0																		
IRONWORKERS	0	0	0	0																		
CARPENTERS	0	0	0	0																		
CEMENT MASONS	0	0	0	0																		
ELECTRICIANS	0	0	0	0																		
PIPEFITTER/PLUMBERS	0	0	0	0																		
PAINTERS	0	0	0	0																		
LABORERS-SEMI SKILLED	0	0	0	0																		
LABORERS-UNSKILLED	0	0	0	0																		
TOTAL	0	0	0	0	0	0	0	0	0	0	0	0	0	0	0	0	0	0	0	0	0	0

TABLE C (Table B data by racial status)

APPRENTICES	0	0	0	0																		
OJT TRAINEES	0	0	0	0																		
8. PREPARED BY: (Signature and Title of Contractors Representative)	9. DATE								10. REVIEWED BY: (Signature and Title of State Highway Official)								11. DATE					

Form FHWA- 1391 (Rev. 09-13)

PREVIOUS EDITIONS ARE OBSOLETE

Federal Project No: TAP-0031-(348)
NDOT Project No: 61107

118

CONTRACTOR'S MONTHLY REPORT OF PAYMENTS TO SUBCONTRACTORS

The Contract Documents require each contractor to submit to Carson City a monthly report of payments to its subcontractors. This applies to all tiers of subcontracting. Monthly updates are to be submitted on this form and provided to the City's Construction Manager overseeing the contract.

Business name and address of the contractor making payment:	CONTRACT NUMBER: _____
---	------------------------

	Date Invoiced by Subcontractor	Amount Invoiced by Subcontractor	Date Subcontractor was Paid	Amount Paid for Work or Services	Amount Paid for Supplies
Subcontractor name: Total subcontract amount: \$					
Subcontractor name: Total subcontract amount: \$					
Subcontractor name: Total subcontract amount: \$					
Subcontractor name: Total subcontract amount: \$					
Subcontractor name: Total subcontract amount: \$					
Subcontractor name: Total subcontract amount: \$					
Subcontractor name: Total subcontract amount: \$					

Signature of authorized representative of the contractor	Title of person signing	Date Submitted
--	-------------------------	----------------

The contractor attests that the information provided is accurate.

CHECK ONE:

- 5 – 8 hour days
- 4 – 10 hour days

WAGE COMPARISON WORKSHEET

Project Name _____ Location _____ Date _____

Date & Modification of Federal Wage Rates _____ Date of State Rates _____

Classification	Group		Area Zone		Federal Rate			State Rate			Rate To Be Paid			Fed/State
	Fed (if applies)	State (if applies)	Fed (if applies)	State (if applies)	Base Rate*	Fringe Benefit	Total	Base Rate*	Fringe Benefit	Total	Base Rate	Fringe Benefit	Total	

Notes:

The higher base rate will determine whether the contractor will pay Davis-Bacon (Federal) or State rates for each classification. This only applies to contracts \$250,000 and over; only the Federal Wage Rates need to be used for contracts \$2,000 and above, if the total project cost is less than \$250,000 then State rates do not apply.

Note* Add the zone rate or travel differential to the base rate to get the total base rate.

Use additional forms if necessary. **CONTRACTOR SIGNATURE & DATE:** _____

Certification for a Drug-Free Workplace

U.S. Department of Housing
and Urban Development

Applicant Name

Program/Activity Receiving Federal Grant Funding

Acting on behalf of the above named Applicant as its Authorized Official, I make the following certifications and agreements to the Department of Housing and Urban Development (HUD) regarding the sites listed below:

I certify that the above named Applicant will or will continue to provide a drug-free workplace by:

a. Publishing a statement notifying employees that the unlawful manufacture, distribution, dispensing, possession, or use of a controlled substance is prohibited in the Applicant's workplace and specifying the actions that will be taken against employees for violation of such prohibition.

b. Establishing an on-going drug-free awareness program to inform employees ---

- (1) The dangers of drug abuse in the workplace;
- (2) The Applicant's policy of maintaining a drug-free workplace;
- (3) Any available drug counseling, rehabilitation, and employee assistance programs; and
- (4) The penalties that may be imposed upon employees for drug abuse violations occurring in the workplace.

c. Making it a requirement that each employee to be engaged in the performance of the grant be given a copy of the statement required by paragraph a.;

d. Notifying the employee in the statement required by paragraph a. that, as a condition of employment under the grant, the employee will ---

(1) Abide by the terms of the statement; and

(2) Notify the employer in writing of his or her conviction for a violation of a criminal drug statute occurring in the workplace no later than five calendar days after such conviction;

e. Notifying the agency in writing, within ten calendar days after receiving notice under subparagraph d.(2) from an employee or otherwise receiving actual notice of such conviction. Employers of convicted employees must provide notice, including position title, to every grant officer or other designee on whose grant activity the convicted employee was working, unless the Federalagency has designated a central point for the receipt of such notices. Notice shall include the identification number(s) of each affected grant;

f. Taking one of the following actions, within 30 calendar days of receiving notice under subparagraph d.(2), with respect to any employee who is so convicted ---

(1) Taking appropriate personnel action against such an employee, up to and including termination, consistent with the requirements of the Rehabilitation Act of 1973, as amended; or

(2) Requiring such employee to participate satisfactorily in a drug abuse assistance or rehabilitation program approved for such purposes by a Federal, State, or local health, law enforcement, or other appropriate agency;

g. Making a good faith effort to continue to maintain a drug-free workplace through implementation of paragraphs a. thru f.

2. Sites for Work Performance. The Applicant shall list (on separate pages) the site(s) for the performance of work done in connection with the HUD funding of the program/activity shown above: Place of Performance shall include the street address, city, county, State, and zip code. Identify each sheet with the Applicant name and address and the program/activity receiving grant funding.)

Check here if there are workplaces on file that are not identified on the attached sheets.

I hereby certify that all the information stated herein, as well as any information provided in the accompaniment herewith, is true and accurate.
Warning: HUD will prosecute false claims and statements. Conviction may result in criminal and/or civil penalties.
(18 U.S.C. 1001, 1010, 1012; 31 U.S.C. 3729, 3802)

Name of Authorized Official		Title
Signature		Date
X		

WAGES AND CONDITIONS OF EMPLOYMENT

The provisions pertaining to wages and conditions of employment shall apply to all work performed (on the contract) by the Contractor with his own organization and with the assistance of workmen under his immediate superintendence, and to all work performed on the contract by subcontractors.

Minimum wage rates determined by the Labor Commissioner of the State of Nevada and by the Secretary of Labor, if applicable, are set forth in the contract documents. Do not pay wage rates less than the minimum wage rates.

Forfeit, as a penalty to the *City of Sparks*, the amount stipulated in NRS Chapter 338 when workmen are paid less than the minimum wage rate.

The laborers shall have access to the pertinent minimum wage schedules at all times. Provide and erect a weatherproof bulletin board at the job site and post all minimum wage schedules and other required information thereon. Construct the weatherproof bulletin board so that the material thereon is adequately protected from the elements.

It is a condition of the contract, and shall be made a condition of each subcontract entered into pursuant to the contract, that the Contractor and any subcontractor shall not require any laborer or mechanic employed in performance of the contract to work in surroundings or under working conditions which are unsanitary, hazardous, or dangerous to his health or safety as determined under construction safety and health standards (Title 29, Code of Federal Regulations, Part 1926—published in the Federal Register on December 16, 1972, and subsequent revisions) promulgated by the United States Secretary of Labor, according to Section 107 of the Contract Work Hours and Safety Standards Act, (83 Stat. 96).

The minimum wage rates apply to workmen working upon the “site of the work.” The term “site of the work” is defined as follows:

The “site of the work” is defined as the physical place or places where work called for in the contract is performed by either the Contractor or the Contractor’s agents. Material sources controlled by the Local Agency and staging areas set up to construct portions of the work are considered to be the “site of the work.” Not included in the “site of the work” are permanent home offices, batch plant establishments, fabrication plants, and tool yards of an employer whose locations and continuance in operation are determined without regard to the work. In addition, fabrication plants, batch plants, borrow pits, job headquarters, tool yards, or other like locations of a commercial supplier or materialman which are established by a supplier of materials for the project before opening of bids are not included in the “site of the work.”

The Contractor and subcontractors compliance with Title 29, subtitle A, 3.3, Code of Federal Regulations and NRS 338 will be required on this contract. These regulations require submittal of a tally of weekly payroll and statement of compliance with respect to each employee engaged in work on the project. Submit these payrolls and statement of compliance to the Nevada Department of Transportation and the State of Nevada Labor Commissioner.

Submit payrolls to the City of Sparks, as directed. This requirement will apply to every lower-tier subcontractor and vendor required to provide certified payroll reports by NRS 338.010 to 338.090 inclusive.

110.02 Laws Cited. See the provisions and requirements of the following:

- (a) Wages, Hours and Employment on Public Works—NRS Chapter 338.
- (b) Nevada Industrial Insurance Act—NRS Chapter 616A. Furnish a certificate from the insurer as evidence of payment of all the premiums and percentages as required by the act, and furnish said certificate before any work is commenced.

- (c) Unemployment Compensation Law—NRS Chapter 612.
- (d) Highway Camp Sanitation—NRS 444.130, 444.200 and 444.210.
- (e) Fair Labor Standards Act of 1938 (52 Stat. 1060).
- (f) Work Hours Act of 1962.
- (g) Any and all legislation, rules or regulations promulgated by the State of Nevada, or its agencies, covering any work performed by the Contractor.
- (h) Fraudulent and Discriminatory Employment Practices—NRS Chapter 613.

BIDDER DISADVANTAGED BUSINESS ENTERPRISE (DBE) INFORMATION

Contract No: _____

Contractor: _____

Project No(s): _____

Address: _____

Total Bid Amount \$ _____

Contract DBE Goal: _____%

This information must be submitted with the bid proposal. Please list all subcontractors used to fulfill the DBE requirements for this contract. A bidder unable to meet the DBE goal shall submit documentation to outline their Good Faith Efforts (GFE) toward meeting the contract goal. Total DBE participation is subject to verification. Please fill out the form completely. Use additional forms if necessary.

DBE SUBCONTRACTORS:

DBE NAME AND ADDRESS	DBE PHONE NO.	PROPOSAL ITEM NO(S).	100% DBE SUB BID AMOUNT	DBE CERTIFICATION NO.*	DESCRIPTION OF WORK OR SERVICES TO BE CONTRACTED OR SUPPLIES TO BE SUPPLIED
A. TOTAL OF SUBCONTRACTOR DBE BID AMOUNT:					

DBE SUPPLIERS:

DBE NAME AND ADDRESS	DBE PHONE NO.	PROPOSAL ITEM NO(S).	100% DBE SUB BID AMOUNT	60% DBE SUPPLIER BID AMOUNT (PARTICIPATION)	DBE CERTIFICATION NO.*	DESCRIPTION OF WORK OR SERVICES TO BE CONTRACTED OR SUPPLIES TO BE SUPPLIED
B. TOTAL OF SUBCONTRACTOR DBE BID AMOUNT:						

C. Total Dollar Value of DBE Participation (add totals from lines A & B): \$ _____**

D. Total percent of DBE participation (divide line c by total bid amount): _____%

Contractor's Signature Date

*DBEs must be certified by the Nevada Unified Certification Program.

**DBE Participation amount is 100% of the subcontractor's bid amount and 60% of the supplier's bid amount.

Telephone No. _____

REV. 09/13

LIST OF SUBCONTRACTORS AND SUPPLIERS BIDDING

Contract No: _____

Contractor: _____

List all subcontractors providing bids to your firm for this contract. You may make copies of this form.

This form must be submitted no later than 5:00 pm the next business day after the bid opening time.

SUBCONTRACTOR NAME AND ADDRESS	SUBCONTRACTOR PHONE NO.	NEVADA CONTRACTOR LICENSE # (IF APPLICABLE)	LICENSE LIMIT (IF APPLICABLE)	USED?		DBE CERTIFIED?		SUPPLIER?	
				Yes	No	Yes	No	Yes	No
				Yes	No	Yes	No	Yes	No
				Yes	No	Yes	No	Yes	No
				Yes	No	Yes	No	Yes	No
				Yes	No	Yes	No	Yes	No
				Yes	No	Yes	No	Yes	No
				Yes	No	Yes	No	Yes	No
				Yes	No	Yes	No	Yes	No
				Yes	No	Yes	No	Yes	No
				Yes	No	Yes	No	Yes	No
				Yes	No	Yes	No	Yes	No
				Yes	No	Yes	No	Yes	No
				Yes	No	Yes	No	Yes	No
				Yes	No	Yes	No	Yes	No
				Yes	No	Yes	No	Yes	No

REV. 09/13

DAVIS BACON WAGE DETERMINATION

State: Nevada

Construction Type: Highway

Counties: Storey and Washoe Counties in Nevada.

Note: Contracts subject to the Davis-Bacon Act are generally required to pay at least the applicable minimum wage rate required under Executive Order 14026 or Executive Order 13658. Please note that these Executive Orders apply to covered contracts entered into by the federal government that are subject to the Davis-Bacon Act itself, but do not apply to contracts subject only to the Davis-Bacon Related Acts, including those set forth at 29 CFR 5.1(a)(1).

<p>If the contract is entered into on or after January 30, 2022, or the contract is renewed or extended (e.g., an option is exercised) on or after January 30, 2022:</p>	<ul style="list-style-type: none"> ◆ Executive Order 14026 generally applies to the contract. ◆ The contractor must pay all covered workers at least \$17.20 per hour (or the applicable wage rate listed on this wage determination, if it is higher) for all hours spent performing on the contract in 2024.
<p>If the contract was awarded on or between January 1, 2015 and January 29, 2022, and the contract is not renewed or extended on or after January 30, 2022:</p>	<ul style="list-style-type: none"> ◆ Executive Order 13658 generally applies to the contract. ◆ The contractor must pay all covered workers at least \$12.90 per hour (or the applicable wage rate listed on this wage determination, if it is higher) for all hours performing on that contract in 2024.

The applicable Executive Order minimum wage rate will be adjusted annually. If this contract is covered by one of the Executive Orders and a classification considered necessary for performance of work on the contract does not appear on this wage determination, the contractor must still submit a conformance request.

Additional information on contractor requirements and worker protections under the Executive Orders is available at <http://www.dol.gov/whd/govcontracts>.

Modification Number	Publication Date
0	05/24/2024
1	07/05/2024
2	07/19/2024
3	08/02/2024
4	08/23/2024

CARP1977-008 07/01/2023

	Rates	Fringes
CARPENTER.....	\$ 46.54	23.87

 ELEC0357-006 06/01/2024

	Rates	Fringes
ELECTRICIAN.....	\$ 57.48	24.39

 * ENGI0003-039 07/01/2024

	Rates	Fringes
OPERATOR: Backhoe Loader Combo.....	\$ 49.93	30.38

 * ENGI0003-040 07/01/2024

	Rates	Fringes
OPERATOR: Backhoe/Excavator/Trackhoe.....	\$ 50.47	30.38

 * ENGI0003-041 07/01/2024

	Rates	Fringes
OPERATOR: Bobcat/Skid Steer/Skid Loader.....	\$ 47.56	30.38

 * ENGI0003-043 07/01/2024

	Rates	Fringes
OPERATOR: Grade Checker.....	\$ 50.71	30.38
OPERATOR: Grader/Blade.....	\$ 50.71	30.38

 * ENGI0003-049 07/01/2024

	Rates	Fringes
OPERATOR: Loader Loader over 2 1/2 cu.yds. up to and including 4 cu.yds.....	\$ 50.28	30.38

 * ENGI0003-053 07/01/2024

	Rates	Fringes
OPERATOR: Mechanic.....	\$ 50.28	30.38

 * ENGI0003-055 07/01/2024

	Rates	Fringes
OPERATOR: Oiler.....	\$ 46.76	30.38

 * ENGI0003-057 07/01/2024

	Rates	Fringes
OPERATOR: Paver (Asphalt,		

Aggregate, and Concrete).....\$ 50.71 30.38

* ENGI0003-065 07/01/2024

Rates Fringes

OPERATOR: Roller.....\$ 49.61 30.38

* ENGI0003-066 07/01/2024

Rates Fringes

OPERATOR: Screed.....\$ 49.61 30.38

ENGI0012-029 10/01/2023

Rates Fringes

OPERATOR: Drill
Drilling depth of 105'
maximum.....\$ 58.12 32.35
Drilling depth of 45'
maximum.....\$ 57.89 32.35

ENGI0012-030 10/01/2023

Rates Fringes

OPERATOR: Forklift
Under 5 Tons.....\$ 54.94 32.35

ENGI0012-031 10/01/2023

Rates Fringes

OPERATOR: Crane (Oiler)
40 tons up to and
including 200 ton M.R.C.....\$ 58.62 32.35
OPERATOR: Crane
Heavy Duty Repairman.....\$ 59.76 32.35

ENGI0012-041 10/01/2023

Rates Fringes

OPERATOR: Scraper.....\$ 58.00 32.35

IRON0118-016 01/01/2024

Rates Fringes

IRONWORKER, REINFORCING.....\$ 47.45 34.90

IRON0433-011 07/01/2021

Rates Fringes

IRONWORKER, STRUCTURAL.....\$ 43.00 32.83

LAB00169-010 10/01/2023

Rates Fringes

LABORER: Mason Tender -
Cement/Concrete.....\$ 32.70 15.70

LABORER: Jackhammer.....\$ 32.70 15.70

LAB00169-011 10/01/2023

Rates Fringes

LABORER: Common or General.....\$ 32.45 15.70

LAB00169-012 10/01/2023

Rates Fringes

LABORER: Concrete Saw.....\$ 32.70 15.70

LAB00169-013 10/01/2023

Rates Fringes

TRAFFIC CONTROL:

Laborer-Cones/

Barricades/Barrels -

Setter/Mover/Sweeper.....\$ 35.20 15.70

LAB00169-014 10/01/2023

Rates Fringes

LABORER: Asphalt, Includes

Raker, Shoveler, Spreader and

Distributor.....\$ 32.95 15.70

LABORER: Pipelayer.....\$ 32.95 15.70

LAB00169-016 10/01/2023

Rates Fringes

TRAFFIC CONTROL: Flagger.....\$ 30.58 15.70

PLAS0797-010 10/01/2023

Rates Fringes

CEMENT MASON/CONCRETE FINISHER...\$ 38.85 12.90

SUNV2021-014 03/01/2024

Rates Fringes

LABORER: Landscape.....\$ 34.92 0.00

PAINTER.....\$ 50.37 0.00

TRUCK DRIVER: Dump Truck.....\$ 26.77 0.00

TRUCK DRIVER: Water Truck.....\$ 27.11 0.00

WELDERS - Receive rate prescribed for craft performing operation to which welding is incidental.

Note: Executive Order (EO) 13706, Establishing Paid Sick Leave for Federal Contractors applies to all contracts subject to the Davis-Bacon Act for which the contract is awarded (and any

solicitation was issued) on or after January 1, 2017. If this contract is covered by the EO, the contractor must provide employees with 1 hour of paid sick leave for every 30 hours they work, up to 56 hours of paid sick leave each year. Employees must be permitted to use paid sick leave for their own illness, injury or other health-related needs, including preventive care; to assist a family member (or person who is like family to the employee) who is ill, injured, or has other health-related needs, including preventive care; or for reasons resulting from, or to assist a family member (or person who is like family to the employee) who is a victim of, domestic violence, sexual assault, or stalking. Additional information on contractor requirements and worker protections under the EO is available at <https://www.dol.gov/agencies/whd/government-contracts>.

Unlisted classifications needed for work not included within the scope of the classifications listed may be added after award only as provided in the labor standards contract clauses (29CFR 5.5 (a) (1) (iii)).

The body of each wage determination lists the classification and wage rates that have been found to be prevailing for the cited type(s) of construction in the area covered by the wage determination. The classifications are listed in alphabetical order of ""identifiers"" that indicate whether the particular rate is a union rate (current union negotiated rate for local), a survey rate (weighted average rate) or a union average rate (weighted union average rate).

Union Rate Identifiers

A four letter classification abbreviation identifier enclosed in dotted lines beginning with characters other than ""SU"" or ""UAVG"" denotes that the union classification and rate were prevailing for that classification in the survey. Example: PLUM0198-005 07/01/2014. PLUM is an abbreviation identifier of the union which prevailed in the survey for this classification, which in this example would be Plumbers. 0198 indicates the local union number or district council number where applicable, i.e., Plumbers Local 0198. The next number, 005 in the example, is an internal number used in processing the wage determination. 07/01/2014 is the effective date of the most current negotiated rate, which in this example is July 1, 2014.

Union prevailing wage rates are updated to reflect all rate changes in the collective bargaining agreement (CBA) governing this classification and rate.

Survey Rate Identifiers

Classifications listed under the ""SU"" identifier indicate that no one rate prevailed for this classification in the survey and the published rate is derived by computing a weighted average rate based on all the rates reported in the survey for that classification. As this weighted average rate includes all rates reported in the survey, it may include both union and non-union rates. Example: SULA2012-007 5/13/2014. SU indicates the rates are survey rates based on a weighted average calculation of rates and are not majority rates. LA indicates

the State of Louisiana. 2012 is the year of survey on which these classifications and rates are based. The next number, 007 in the example, is an internal number used in producing the wage determination. 5/13/2014 indicates the survey completion date for the classifications and rates under that identifier.

Survey wage rates are not updated and remain in effect until a new survey is conducted.

Union Average Rate Identifiers

Classification(s) listed under the UAVG identifier indicate that no single majority rate prevailed for those classifications; however, 100% of the data reported for the classifications was union data. EXAMPLE: UAVG-OH-0010 08/29/2014. UAVG indicates that the rate is a weighted union average rate. OH indicates the state. The next number, 0010 in the example, is an internal number used in producing the wage determination. 08/29/2014 indicates the survey completion date for the classifications and rates under that identifier.

A UAVG rate will be updated once a year, usually in January of each year, to reflect a weighted average of the current negotiated/CBA rate of the union locals from which the rate is based.

State Adopted Rate Identifiers

Classifications listed under the "SA" identifier indicate that the prevailing wage rate set by a state (or local) government was adopted under 29 C.F.R. 1.3(g)-(h). Example: SAME2023-007 01/03/2024. SA reflects that the rates are state adopted. ME refers to the State of Maine. 2023 is the year during which the state completed the survey on which the listed classifications and rates are based. The next number, 007 in the example, is an internal number used in producing the wage determination. 01/03/2024 reflects the date on which the classifications and rates under the SA identifier took effect under state law in the state from which the rates were adopted.

WAGE DETERMINATION APPEALS PROCESS

1.) Has there been an initial decision in the matter? This can be:

- * an existing published wage determination
- * a survey underlying a wage determination
- * a Wage and Hour Division letter setting forth a position on a wage determination matter
- * a conformance (additional classification and rate) ruling

On survey related matters, initial contact, including requests for summaries of surveys, should be with the Wage and Hour National Office because National Office has responsibility for the Davis-Bacon survey program. If the response from this initial contact is not satisfactory, then the process described in 2.) and 3.) should be followed.

With regard to any other matter not yet ripe for the formal process described here, initial contact should be with the Branch of Construction Wage Determinations. Write to:

Branch of Construction Wage Determinations

Wage and Hour Division
U.S. Department of Labor
200 Constitution Avenue, N.W.
Washington, DC 20210

2.) If the answer to the question in 1.) is yes, then an interested party (those affected by the action) can request review and reconsideration from the Wage and Hour Administrator (See 29 CFR Part 1.8 and 29 CFR Part 7). Write to:

Wage and Hour Administrator
U.S. Department of Labor
200 Constitution Avenue, N.W.
Washington, DC 20210

The request should be accompanied by a full statement of the interested party's position and by any information (wage payment data, project description, area practice material, etc.) that the requestor considers relevant to the issue.

3.) If the decision of the Administrator is not favorable, an interested party may appeal directly to the Administrative Review Board (formerly the Wage Appeals Board). Write to:

Administrative Review Board
U.S. Department of Labor
200 Constitution Avenue, N.W.
Washington, DC 20210

4.) All decisions by the Administrative Review Board are final.

=====

END OF GENERAL DECISION"

NEVADA PREVAILING WAGE RATES

STATE OF NEVADA

JOE LOMBARDO
GOVERNOR

DR. KRISTOPHER SANCHEZ
DIRECTOR

BRETT HARRIS
LABOR COMMISSIONER



OFFICE OF THE LABOR COMMISSIONER
1818 COLLEGE PARKWAY, SUITE 102
CARSON CITY, NV 89706
PHONE: (775) 684-1890
FAX (775) 687-6409
OFFICE OF THE LABOR COMMISSIONER
3340 WEST SAHARA AVENUE
LAS VEGAS, NV 89102
PHONE: (702) 486-2650
FAX (702) 486-2660
EMAIL: PUBLICWORKS@LABOR.NV.GOV

2024 PREVAILING WAGE RATES WASHOE COUNTY REGION

DATE OF DETERMINATION: October 1, 2023

**APPLICABLE FOR PUBLIC WORKS PROJECTS OVER \$100,000 BID/AWARDED
OCTOBER 1, 2023 THROUGH SEPTEMBER 30, 2024**

Pursuant to Nevada Revised Statutes (NRS) section 338.030(9)(a), "If the contract for a public work: (a) Is to be awarded pursuant to a competitive bidding process, the prevailing wages in effect at the time of the opening of the bids for a contract for a public work must be paid until the completion or termination of the contract or for the 36 months immediately following the date on which the bids were opened, whichever is earlier." For contracts not awarded pursuant to competitive bidding, please see NRS section 338.030(9)(b). However, if a project exceeds 36 months new wage rates may apply pursuant to NRS section 338.030(9)(10). Prevailing Wage Rates may be adjusted based on Collective Bargaining Agreements (CBA's) and adjustments to those agreements. (See NRS 338.030)

PREVAILING WAGE DETERMINATIONS - NRS 338.030 subsection 7, the wages so determined must be:

- (a) Issued by the Labor Commissioner on October 1 of the odd-numbered year in which the survey was conducted and, except as otherwise provided in subsection 8, remain effective for 2 years after that date; and
- (b) Made available by the Labor Commissioner to any public body which awards a contract for any public work.

Senate Bill 243 passed during the 80th Nevada Legislative Session (2019) and set forth in NRS section 338.025, now requires the Labor Commissioner to calculate the Prevailing Wage Rates by region. NRS section 338.025 Prevailing wage regions. For the purpose of determining the prevailing rate of wages pursuant to NRS section 338.030, four prevailing wage regions are hereby established in this State as follows:

1. The Washoe Prevailing Wage Region consisting of Washoe County;
2. The Northern Rural Prevailing Wage Region consisting of Carson City and the counties of Churchill, Douglas, Elko, Eureka, Humboldt, Lander, Lyon, Mineral, Storey, Pershing and White Pine;
3. The Clark Prevailing Wage Region consisting of Clark County; and
4. The Southern Rural Prevailing Wage Region consisting of the counties of Esmeralda, Lincoln and Nye.

OBJECTIONS TO PREVAILING WAGE DETERMINATIONS – NRS section 338.030 subsection 2. Objections to the Prevailing Wage Determinations must be submitted within 30 days after the Prevailing Wage Determinations are issued.

Pursuant to NRS section 338.030 subsection 8, the Labor Commissioner will review the prevailing wage rates in each even-numbered year to determine if adjustments should be made.

As Amendments/Revisions are made to the wage rates, they will be posted on the website for each respective Region. Please review regularly for any Amendments/Revisions that are posted or contact our offices directly for further assistance.

Air Balance Technician	4
Alarm Installer	5
Boilermaker	6
Bricklayer	7
Carpenter	8
Cement Mason	9
Electrician – Communication Technician	10
Electrician - Lineman	11
Electrician – Neon Sign	13
Electrician - Wireman	14
Elevator Constructor	15
Fence Erector	17
Flagperson	18
Floorcoverer	19
Glazier	20
Highway Striper	22
Hod Carrier-Brick Mason	23
Hod Carrier – Plasterer Tender	24
Ironworker	26
Laborer	29
Lubrication And Service Engineer (Mobile And Grease Rack)	30
Mechanical Insulator	31
Millwright	32
Operating Engineer	35
Operating Engineer – Steel Fabricator & Erector	35
Operating Engineer – Piledriver	36
Painter	38
Piledriver (Non-Equipment)	40
Plasterer	42
Plumber/Pipefitter	43
Refrigeration	44
Roofer	45
Sheet Metal Worker	46
Soils and Material Tester	47
Sprinkler Fitter	47
Surveyor	48
Taper	49
Tile/Terrazzo Worker/Marble Mason Finisher	50
Tile/Terrazzo Worker/Marble Mason	51
Traffic Barrier Erector	53
Truck Driver	54
Well Driller	56
Group Classifications	
Labor Group Classifications	57
Operating Engineers	61

NRS section 338.010 subsection (25) “Wages” means:

- a) The basic hourly rate of pay; and
- b) The amount of pension, health and welfare, vacation and holiday pay, the cost of apprenticeship training or other similar programs or other bona fide fringe benefits which are a benefit to the worker.

NRS section 338.035 Bona Fide Fringe Benefits - Discharge of part of obligation of contractor or subcontractor engaged on public work to pay wages by making certain contributions in name of workman. “Bona fide fringe benefit” means a benefit in the form of a contribution that is made not less frequently than monthly to an independent third party pursuant to a fund, plan or program: (a) Which is established for the sole and exclusive benefit of a worker and his or her family and dependents; and (b) For which none of the assets will revert to, or otherwise be credited to, any contributing employer or sponsor of the fund, plan or program. The term includes, without limitation, benefits for a worker that are determined pursuant to a collective bargaining agreement and included in the determination of the prevailing wage by the Labor Commissioner pursuant to NRS section 338.030.

Please see NRS sections 338.010, 338.020, and 338.035 and Nevada Administrative Code (NAC) sections 338.0097 and 338.092 through 338.100 for further details on “Bona fide fringe benefits” and reporting requirements and exceptions.

Job Descriptions for Recognized Classes of Workers

Regarding job descriptions for public works projects, please take notice of the following:

1. The job description links have been redacted to include ONLY the scope of work for the craft.
2. Pursuant to NAC section 338.0095(1)(a) - A worker employed on a public work must be paid the applicable prevailing rate of wage for the type of work that the worker actually performs on the public work and in accordance with the recognized class of the worker.
3. The work description for a particular class is not intended to be jurisdictional in scope.
4. Any person who believes that a type of work is not classified, or who otherwise needs clarification pertaining to the recognized classes or job descriptions, shall contact the Labor Commissioner in writing for a determination of the applicable classification and pay rate for a particular type of work.
5. The job descriptions set forth or referenced herein supersede any, and all descriptions previously agreed upon by the Labor Commissioner in any settlement agreements or stipulations arising out of contested matters.
6. The following specific provisions, where applicable, shall prevail over any general provisions of the job descriptions:
 - Amendments to the prevailing wage determinations.
 - Group Classifications and/or descriptions recognized by the Labor Commissioner and included with wage determinations for a particular type of work in a particular county.

Zone Rates

The zone rate has been added to each applicable craft.

Premium Pay Premium pay for hours worked in excess of a shift of 8 hours or 12 hours, or such other time increment set forth in the Collective Bargaining Agreement or on a weekend or holiday.

Craft: AIR BALANCE TECHNICIAN (Union Rate)

Prevailing wage rates include the base rate as well as all applicable fringes

Air Balance Technician Journeyman.....	73.87
Air Balance Technician-Foreman.....	78.26
Air Balance Technician-General Foreman.....	82.65

ADD ZONE RATE

In addition to AIR BALANCE rates add the applicable amounts per hour, calculated based on a road from the courthouse in Reno, Nevada:

Zone 1	0 to 75 miles	\$0.00
Zone 2	75 to 100 miles	\$5.00
Zone 3	Over 100 miles	\$10.00 the employee shall be provided reasonable lodging and meal expenses.

ADD PREMIUM PAY

All hourly rates are subject to Over Time (One and one half 1 ½) of the Regular rate:

1. For all hours worked over Eight (8) Hours in one day or shift.
2. For the first Eight (8) Hours work on Saturday.

All hourly rates are subject to Double Time of the Regular Rate:

1. For all hours worked over Ten (10) Hours in one day or shift.
2. For all hours worked over Eight (8) Hours on Saturday.
3. For all hours worked on Sunday, New Year’s Day, President’s Day, Memorial Day, Independence Day, Labor Day, Nevada Day, Thanksgiving Day, Day after Thanksgiving, Day before Christmas, and Christmas Day.

RECOGNIZED HOLIDAYS

New Year’s Day, President’s Day, Memorial Day, Independence Day, Labor Day, Nevada Day, Thanksgiving Day, Day after Thanksgiving, Day before Christmas, and Christmas Day

JOB DESCRIPTION: Excerpt from Sheet Metal Local 26 Collective Bargaining Agreement

(a) manufacture, fabrication, assembling, handling, erection, installation, dismantling, conditioning, adjustment, alteration, repairing and servicing of all ferrous or nonferrous metal work and all other materials used in lieu thereof and of all HVAC systems, air veyor systems, exhaust systems, and air-handling systems regardless of material used including the setting of all equipment and all reinforcements in connection therewith; (b) all lagging over insulation and all duct lining; (c) testing and balancing of all air-handling equipment and duct work; (d) the preparation of all shop and field sketches whether manually drawn or computer assisted used in fabrication and erection, including those taken from original architectural and engineering drawings or sketches; (e) metal roofing; and (f) all other work included in the jurisdictional claims of International Association of Sheet Metal, Air, Rail and Transportation Workers.

Craft: ALARM INSTALLER (Non-Union Rate)

Prevailing wage rates include the base rate as well as all applicable fringes

Alarm Installer.....39.90

JOB DESCRIPTION:

Includes but is not limited to:

1. Installing or testing electrical protective signaling systems used to provide notification of fire, burglary or other irregularities on the premises of the subscriber of the system;
2. Installing of wiring and signaling units;
3. Repairing electrical protective signaling systems
4. Starting up, programming and documenting systems;

Craft: BOILERMAKER (Union Rate)
Prevailing wage rates include the base rate as well as all applicable fringes

Boilermaker.....	72.01
Boilermaker Foreman.....	74.51

ADD PREMIUM PAY

Premium pay for hours worked in excess of a shift of 8 hours or 12 hours or such other time increment set forth in the Collective Bargaining Agreement or on a weekend or holiday.

PER DIEM payments and TRAVEL pay shall be paid as follows:

The Contractor shall pay the employee Per Diem in the amount of seventy-five dollars (\$75.00) per day worked where the job site is 70 miles or more but less than 120 miles from the dispatch point.

For mileage of 120 miles or more, the daily Per Diem amount shall be ninety dollars (\$90.00) per day worked.

Where the job site is over 120 miles or more from the dispatch point, employees shall receive the I.R.S. maximum allowable per mile for transportation between the dispatch point and the job site at the beginning and conclusion of their employment.

Where a job is located two hundred and forty (240) miles or more from the dispatch point, the employee will receive one additional day's Per Diem at the beginning of employment and one additional day's Per Diem at the conclusion of employment.

JOB DESCRIPTION:

Includes but is not limited to:

1. Constructing, assembling, maintaining and repairing stationary steam boilers and boiler house auxiliaries;
2. Aligning structures or plate sections to assemble boiler frame tanks or vats;
3. Assisting in the testing of assembled vessels, directing cleaning of boilers and boiler furnaces;
4. Inspecting and repairing boiler fittings, including, without limitation, safety valves, regulators, automatic-control mechanisms, water columns and auxiliary machines.

Craft: BRICKLAYER (Union Rate)
Prevailing wage rates include the base rate as well as all applicable fringes

SEE AMENDMENT 1

Bricklayer Journeyman.....	51.71
Bricklayer Foreman.....	52.96

ADD ZONE PAY in addition to BRICKLAYER rates add the applicable amounts per hour, calculated based on road miles of over thirty-five (35) miles from the Washoe County Courthouse in Reno, Nevada:

Zone 1	0 to 35 miles	\$0.00
Zone 2	35 to 75 miles	\$2.50
Zone 3	Over 75 miles	\$8.12

ADD PREMIUM PAY

One and one half (1 ½) the regular straight time hourly rate shall be paid:

1. For all hours worked over eight (8) hours in one day or shift.
2. For any hours worked on Saturday from midnight to midnight.

Double the regular straight time hourly rate shall be paid for all time:

1. For all hours worked over twelve (12) hours in one day or shift.
2. For any hours worked on Sunday from midnight to midnight.
3. For any hours worked on holidays from midnight to midnight.

RECOGNIZED HOLIDAYS

If any of these holidays fall on Sunday, the Monday following shall be considered a Holiday. New Year's Day, President's Day, Memorial Day, Fourth of July, Labor Day, Admission Day, Thanksgiving Day, Day after Thanksgiving Day, Christmas Day.

JOB DESCRIPTION: Excerpt from Agreement between No, NV Masonry Contractors and LIUNA Local 169.

This shall apply to and cover the work of Brick/Block Masonry, Stone Masonry, Artificial Masonry Marble Masonry.

Craft: CARPENTER (Union Rate)

Prevailing wage rates include the base rate as well as all applicable fringes

Carpenter Journeyman.....	58.42
Carpenter Foreman.....	62.06
Carpenter General Foreman.....	66.06

ADD ZONE RATE

(Building and Heavy Highway and Dam Construction)

In addition to CARPENTER rates add the applicable amounts per hour, calculated from the Washoe County Courthouse:

Zone 1	Within 75 road miles	\$0.00
Zone 2	Between 75 to 150 road miles	\$6.00
Zone 3	Between 150 to 300 road miles	\$7.00
Zone 4	In excess of 300 road miles	\$8.00

ADD PREMIUM PAY

Any work performed over eight (8) hours per day and on Saturdays shall be compensated at time and one-half (1-1/2x) the appropriate hourly rate. All work performed on Sundays, holidays and over twelve (12) hours in one (1) day shall be compensated at two times (2x) the appropriate hourly rate. In the event a day's work is lost because of severe weather conditions or major mechanical breakdown, work may be performed on a voluntary basis on a Saturday at the straight time hourly rate for eight (8) hours provided the straight time hours worked in one (1) week do not exceed forty (40) hours.

RECOGNIZED HOLIDAYS

New Year's Day, Memorial Day, 4th of July, Labor Day, Admission's Day, Thanksgiving Day, the Friday after Thanksgiving, Christmas Day.

JOB DESCRIPTION Excerpt from Southwest Regional Council of Carpenters and Affiliated Local Unions Master Labor Agreement

(1) All building construction, including but not limited to the construction, erection, alteration, repair, modification, demolition, addition, or improvement in whole or in part of any building structure. All rigging of Carpenters', and Piledrivers' materials.

(2) All heavy, highway and engineering construction, including but not limited to the construction, improvement, modification and demolition of all or any part of the streets, highways, bridges, viaducts, railroads, tunnels, airports, water supply, irrigation, flood control and draining systems, sewers and sanitation projects, dams, power houses, refineries, aqueducts, canals, river and harbor projects, wharves, docks, breakwaters, jetties, quarrying of breakwaters or rip rap stone or operations incidental to such heavy construction work and whether such work is above or below the water line level.

(3) The character of such work covered by this Agreement shall include but not be limited to all carpenter, concrete form work, shoring, drywall, metal stud, drywall finishing, plaster, scaffold, modular furniture, trade show work, insulation, acoustical, and lathing work on such construction, including but not limited to plastics and such work in connection with new methods of construction or use of materials.

(4) All interior and/or exterior wall finish work, including EIFS and other wet wall finish work.

Craft: CEMENT MASON (Union Rate)

Prevailing wage rates include the base rate as well as all applicable fringes

Cement Mason - Journeyman.....	51.92
Cement Mason - Foreman.....	55.55

ADD ZONE RATE

In addition to CEMENT MASON rates add the applicable amounts per hour, calculated from the Washoe County Courthouse:

Zone 1	0 to 75 miles	\$0.00
Zone 2	75 to 150 miles	\$6.00
Zone 3	150 to 300 miles	\$7.00
Zone 4	More than 300 miles	\$8.00

ADD PREMIUM PAY

OVERTIME – Any worked performed over eight (8) hours per day shall be compensated at time and one half the hourly rate. All work performed after twelve (12) consecutive hours shall be paid at double the hourly rate. All worked performed on Saturdays shall be compensated at time and one half the hourly rate. All Sunday and Holiday work shall be paid for at double time.

RECOGNIZED HOLIDAYS

New Year’s Day, Memorial Day, Independence Day, Labor Day, Admissions Day, Thanksgiving Day and the following Friday following Thanksgiving Day, and Christmas

JOB DESCRIPTIONS

1. All building construction, including but not limited to the construction, erection, alteration, repair, modification, demolition, addition, or improvement in whole or in part of any building structure.
2. All heavy, highway and engineering construction, including but not limited to construction, improvement, modification, demolition, of all or any part of streets and highways (including sidewalks, curbs and gutters), bridges, viaducts, rail roads, tunnels, airports, water supply, irrigation, flood control and drainage systems, sewers and sanitation projects, dams, power houses, refineries, aqueducts, canals, river and harbor projects, wharves, docks, breakwaters, jetties, quarrying of breakwater or rip-rap stone, or operation incidental to such heavy construction work.
3. The work to be performed by Cement Masons shall include but not be limited to the following, when tools of the Cement Masons trade are used or required:
 Setting screeds, screed pins, curb forms and curb and gutter forms, rodding, spreading and tamping concrete, hand application of curing compounds, applying topping (wet or dry) colors or grits; using Darby and push floats, hand troweling or hand floating; marking edging, brooming or brushing, using base cove or step tools; chipping, and stoning, patching or sacking; dry packing; spreading and finishing gypsum, operating mechanical finishers (concrete) such as Clary, Jackson, Bidwell Bridge Deck Paver or similar types; grinding machines; troweling machines, floating machines powered concrete saws; finishing of epoxy and resin materials, bush hammering and exposed finishes for architectural work.
 Operation of skill saw, chain saw, Laser Screed, Laser Level, Curb and Slipform machines, Epoxy Type Injection pumps, stamps or other means of texturing, any new devices, which are beneficial to the construction of or with concrete or related products.

Craft: ELECTRICIAN COMMUNICATION TECHNICIAN (Non-Union Rate)

Prevailing wage rates include the base rate as well as all applicable fringes

Communication Technician.....41.13

JOB DESCRIPTION:

ELECTRONIC COMMUNICATION TECHNICIAN, includes but is not limited to:

1. Pulling cable, installing and trimming devices, terminating loops, circuits, or other data gathering points;
2. Termination of main control panels, racks, or other head end equipment, as well as testing of all circuits from the field devices to the main control panels and/or equipment; 2016-2017 Prevailing Wage Rates – Washoe County 13
3. Utilizing test equipment for the purpose of troubleshooting and verifying the integrity of the circuits in question;
4. Using hand tools to assemble and install data communication lines and equipment computer systems, antennas and towers;
5. Disassembling equipment to adjust, repair or replace parts using hand tools;
6. Starting up, programming and documenting systems;
7. Measuring, cutting, splicing, connecting, soldering and installing wire and cable associated with communication systems.

Craft: ELECTRICIAN LINEMAN/GROUNDMAN/HEAVY EQUIPMENT OPERATOR
(Union Rate)

Prevailing wage rates include the base rate as well as all applicable fringes

Electrician-Groundman.....	39.57
Lineman-Journeyman.....	67.30
Lineman-Foreman.....	73.99
Lineman-General Foreman.....	80.76
Lineman-Equipment Man.....	51.75

ADD PREMIUM PAY

Premium pay for hours worked in excess of a shift of 8 hours or 12 hours or such other time increment set forth in the Collective Bargaining Agreement or on a weekend or holiday.

RECOGNIZED HOLIDAYS

New Year's Day, President's Day, Memorial Day, Fourth of July, Labor Day, Nevada Day, Thanksgiving Day and the Friday following, Christmas Day.

JOB DESCRIPTION:

Outside, overhead and underground construction and maintenance work on electrical transmission lines, switch yards, substations and distribution systems which shall include:

1. Pole line work (whether built of wood, metal or other material): the digging and back-filling of holes for poles or anchors (by hand or mechanical equipment); the loading or unloading, handling, sorting and moving of materials; the assembly or erection of all materials including the guying, stringing of conductors and fiber optics or other work necessary on through to the ultimate completion of such pole work.
2. Steel or metal structures used for the purpose of carrying electrical wire, conductors, or equipment (this includes transmission towers, outdoor substations, switch racks, or similar electrical structures); the moving of men, tools or equipment; the loading or unloading, handling, sorting and moving of materials; the assembly and erection of all materials used on the job site, including the assembly of the grillage and foundations, on through to the ultimate completion of such structures. Work covered shall include the grounding of all such structures except the bonding of stub-angle to rebar cage; the stringing and installation of wires, cables and insulators or other electrical equipment suspended from structure; also the handling and placing of transformers or O.C.B.'s and other related electrical equipment.

The moving of men, tools or equipment; the loading or unloading, handling, sorting and moving of materials; the assembly of all electrical materials on race-ways such as ducts, shall be performed by workmen under the Agreement. This shall also include CIC (cable in conduit), CC (coilable conduit), the placing of fish wire, the pulling of cables or wires through such race-ways, installing and making up of termination and the splicing of such conductors.

Street lighting systems where such work properly comes under the outside jurisdiction shall be handled in the same manner as pole line construction.

Installing and maintaining the catenary and trolley work and bonding of rails shall be handled in the same manner as pole line, and steel construction.

In connection with all of the above items, it is understood the scope of this Agreement shall include not only new installation work but shall also govern the repair, maintenance or dismantling of such structures, lines or equipment; the handling and operating of all equipment used to transport men, tools and/or materials on

the job site as well as the equipment used to move, raise or place materials used in the Outside Branch of the Electrical Industry shall be performed by workmen under this Agreement unless otherwise excluded herein.

Craft: ELECTRICIAN – NEON SIGN (Union Rate)

Prevailing wage rates include the base rate as well as all applicable fringes

Electrician Neon Sign Journeyman.....	63.15
Electrician Neon Sign Foreman.....	65.15
Electrician Neon Sign Truck Foreman supervising (4) or more.....	67.65

ADD PREMIUM PAY

One and one half (1 ½X) the regular straight time hourly rate shall be paid:

1. For all hours worked over eight (8) hours in one day or shift, either before or after the shift.
2. For up to 8 hours worked on Saturday from midnight to midnight.

Double (2X) the regular straight time hourly rate shall be paid for all time:

1. For all hours worked over eleven (11) hours in one day or shift, Monday thru Friday.
2. For all hours worked in excess of 8 hours on Saturday, Sundays or Holidays.

SHIFT DIFFERENTIAL

Second Shift (Swing) will be an additional \$1.25 cents per hour.

Third Shift (Graveyard) will be an additional \$1.50 per hour.

HIGH TIME (Working at heights)

1. All employees working at height of 65 feet and subject to a direct fall shall be paid an additional \$2.75 per hour in addition to their normal rate for a minimum of 2 hours.
2. All employees working at height of 125 feet or when repelling below 65 feet shall be paid an additional \$4.00 per hour in addition to their normal rate for a minimum of 4 hours.

FOREMAN/TRUCK FOREMAN

1. First employee on the job (TRUCK FOREMAN) must have a CDL and Welder certification and shall be paid \$2.00 per hour in addition to their normal rate of pay.

2. When the first employee on the job (FOREMAN) is supervising (4) or more workers, he or she shall be paid an additional \$2.50 per hour. In addition to their normal rate of pay.

3. When the first employee on the job (TRUCK FOREMAN and FOREMAN) has a CDL and Welder certification and is supervising (4) or more workers, he or she shall be paid an additional \$4.50 per hour. In addition to their normal rate of pay.

RECOGNIZED HOLIDAYS

New Year’s Day, Martin Luther King Day, President’s Day unpaid holiday; double time for any hours worked, Memorial Day, Independence Day, Labor Day, Veteran’s Day, Thanksgiving Day, Day after Thanksgiving Day, Christmas Eve ½ day (4 hours) unpaid holiday; straight time for first four hours worked and double time for hours worked after four hours, Christmas Day.

JOB DESCRIPTION Includes but is not limited to:

1. Installing, servicing and repairing plastic, neon and illuminated signs.
2. Ascending ladders or operating hydraulic or electric hoist to install, service, or examine sign to determine cause of malfunction.
3. Wiring, rewiring or removing defective parts and installing new parts using electrician's tools.
4. Removing sign or part of sign for repairs, such as structural fabrication, scroll repair, or transformer repair.

Craft: ELECTRICIAN WIREMAN (Union Rate)

Prevailing wage rates include the base rate as well as all applicable fringes

Wireman.....	69.61
Wireman-Cable Splicer.....	75.41
Wireman Forman.....	75.41
Wireman General Foreman.....	81.21

ADD ZONE RATE

In addition to ELECTRICIAN-Wireman, rates, add the applicable amounts per hour, calculated from Washoe County Courthouse, Reno Nevada:

Zone 1	0 to 70 miles	\$0.00
Zone 2	70 to 90 miles	\$8.00
Zone 3	90 miles and over	\$10.00

ADD PREMIUM PAY

Premium pay for hours worked in excess of a shift of 8 hours or 12 hours or such other time increment

One and one half (1 ½) the regular straight time hourly rate shall be paid:

1. For all hours worked over eight (8) hours in one day or shift.
2. For the first eight (8) hours worked on Saturday

Double the regular straight time hourly rate shall be paid for all time:

3. For all hours worked over ten (10) hours in one day or shift.
4. For any hours worked on Sunday
5. For any hours worked on Holidays

Shift Rates

1. Swing shift to be paid at seventeen-point three (17.3) percent the regular straight time rate for hours between 4:30 p.m. and 1:00 a.m.
2. Graveyard shift to be paid at thirty-one-point four (31.4) percent the regular straight time rate for hours between 12:30 a.m. and 9:00 a.m.
3. Shifts are established for at least five (5) consecutive days or double the regular straight time rate shall be paid.

**Note – Double the straight time rate is the max rate paid. (No pyramiding of overtime rates)

RECOGNIZED HOLIDAYS

New Year’s Day, Memorial Day, Independence Day, Labor Day, Admission Day, Veteran’s Day, Thanksgiving Day, Friday following Thanksgiving Day, Christmas Day.

JOB DESCRIPTION: Excerpt from Agreement between NECA and Local Union 401, IBEW

All electrical construction, installation, or erection work including fabrication or prefabrication of boxes, brackets, bends and nipples and all electrical maintenance thereon including the final running tests. This shall include the installation and maintenance of temporary wiring and the installation of all electrical lighting, heat and power equipment, installation of all raceway systems, including underground conduits and all supports, underground utility conduits, photovoltaic power generation systems, wind power generation systems and geothermal power generating systems. Further all salvage of electrical work shall be included.

Craft: ELEVATOR CONSTRUCTOR (Union Rate)

Prevailing wage rates include the base rate as well as all applicable fringes

Elevator Constructor-Journeyman Mechanic.....	122.16
Elevator Constructor-Journeyman Mechanic In Charge.....	132.63

ADD PREMIUM PAY

Work performed on Construction Work on Saturdays, Sundays and before and after 30 the regular working day on Monday to Friday, inclusive, shall be classed as overtime, and paid for at double the rate of single time.

RECOGNIZED HOLIDAYS

New Year's Day, Memorial Day, Independence Day, Labor Day, Nevada Day, Veteran's Day, Thanksgiving Day, Day after Thanksgiving Day, Christmas Day.

JOB DESCRIPTION: Excerpt from Agreement of International Union of Elevator Constructors

The handling and unloading of all equipment coming under the jurisdiction of the Elevator Constructor, from the time such equipment arrives at or near the building site, shall be handled and unloaded by the Elevator Constructors. Mechanical equipment such as a forklift or truck mounted swing boom may be used by the Elevator Constructors. A derrick, crane or material hoist can be used under the supervision of Elevator Constructors to handle and unload the heavy material described in

Par. 5(a). Where unusual conditions are expected to exist prior to delivery of equipment at or near the building site in regard to handling and unloading of equipment in the primary or secondary jurisdiction of the local union, the Company shall contact the Local's Business Representative to make appropriate arrangements for the handling and unloading of such equipment. In areas outside the jurisdiction of the local union, the Company shall contact the Regional Director.

(b) The erecting and assembling of all elevator equipment to wit: electric, hydraulic, steam, belt, dumbwaiters, residence elevators, parking garage elevators (such as Bowser, Pigeon Hole, or similar types of elevators), shuttles, compressed air and handpower, automatic people movers, monorails, airport shuttles and like-named devices used in the transportation of people for short distances of travel (less than 5 miles), as well as vertical reciprocating conveyor systems.

(c) It is understood and agreed that the preassembly of all escalators, moving stairways and link belt carriers that may be done in the factory shall include the following:

1. Truss or truss sections with tracks, drive units, machines, handrail drive sheaves, drive chains, skirts on the incline sections but not curved sections, step chains and steps installed and permanently aligned.
2. Balustrade brackets may be shipped attached but not aligned.
3. Setting of all controllers and all wiring and conduit from the controller.

All other work on escalators, moving stairways and link belt carriers shall be performed in the field before or after the truss or truss sections are joined and/or hoisted and placed in permanent position. This includes any and all work not done in the factory. The erecting and assembly of all theater stage and curtain elevator equipment and guides and rigging thereto, organ consoles and orchestra elevators

- (d) All wiring, conduit, and raceways from main line feeder terminals on the controller to other elevator apparatus and operating circuits. Controllers are not to be shipped from the factory with extended wiring attached thereto.
- (e) The erecting of all guide rails.
- (f) The installation of all grating under the control of the Company. The installation of all counterweight screens, overhead work, either wood or iron, and all material used for mounting of elevator apparatus in machine room, overhead or below.
- (g) The drilling of overhead beams for attaching machines, sheaves, kick angles, and all other elevator equipment.
- (h) The setting of all templates.
- (i) All foundations, either of wood or metal, that should take the place of masonry.
- (j) The assembly of all cabs complete.
- (k) The installation of all indicators.
- (l) The erecting of all electrical or mechanical automatic or semi-automatic gates complete.
- (m) The hanging of all automatic or semi-automatic elevator hoistway doors, together with the installation of hangers and tracks.
- (n) The installation of all devices for opening and closing and locking of elevator car and hoistway doors and gates.
- (o) The drilling of doors for mounting of closing devices.
- (p) The drilling of angle supports for mounting of closing devices except one template hole.
- (q) The drilling of sills for sill trips.
- (r) The operating of temporary cars.
- (s) The setting of all elevator pressure open or pit tanks.
- (t) The setting of hydraulic power units (power units include: motor, pump, drive valve system, internal piping, muffler, internal wiring, controller and tank). Where power units arrive in parts, they shall be assembled at the job site. The wiring and piping to and between multiple hydraulic power units shall be performed at the job site.
- (u) All air cushions with the exception of those built of brick or those put together with hot rivets.
- (v) Landing door entrances.

Craft: FENCE ERECTOR (Union Rate)

Prevailing wage rates include the base rate as well as all applicable fringes

Fence Erector.....48.78

ADD ZONE RATE

In addition to FENCE ERECTOR rates add the applicable amounts per hour, calculated based on a road miles from either the Carson City Courthouse or the Washoe County Courthouse:

Zone 1	0 to 75 miles	\$0.00
Zone 2	75 to 150 miles	\$6.00
Zone 3	150 to 300 miles	\$7.00
Zone 4	300 miles or over	\$8.00

ADD PREMIUM PAY

One and one half (1 ½) the regular straight time hourly rate shall be paid:

1. For all hours worked over eight (8) hours in one day or shift.
2. For any hours worked on Saturday from midnight to midnight.

Double the regular straight time hourly rate shall be paid for all time:

1. For all hours worked over twelve (12) hours in one day or shift.
2. For any hours worked on Sunday from midnight to midnight.
3. For any hours worked on holidays from midnight to midnight.

RECOGNIZED HOLIDAYS

If any of these holidays fall on Sunday, the Monday following shall be considered a Holiday. New Year’s Day, President’s Day, Memorial Day, Fourth of July, Labor Day, Admission Day, Thanksgiving Day, Day after Thanksgiving Day, Christmas Day.

JOB DESCRIPTION:

Includes but is not limited to:

1. Erecting or repairing chain link, wooden, tortoise, wire/wire mesh, or temporary fencing;
2. Mixing and pouring concrete around bases of posts and tamping soil into post hole to embed post;
3. Digging post holes with a spade, post hole digger or power-driven auger;
4. Aligning posts through the use of lines or by sighting;
5. Verifying vertical alignment of posts with a plumb bob or spirit level.

Craft: FLAG PERSON (Union Rate)

Prevailing wage rates include the base rate as well as all applicable fringes

Flag Person.....46.66

ADD ZONE RATE

In addition to FLAG PERSON add the applicable amounts per hour, calculated based on a road miles from either the Carson City Courthouse or the Washoe County Courthouse:

Zone 1	0 to 75 miles	\$0.00
Zone 2	75 to 150 miles	\$6.00
Zone 3	150 to 300 miles	\$7.00
Zone 4	300 miles or over	\$8.00

ADD PREMIUM PAY

One and one half (1 ½) the regular straight time hourly rate shall be paid:

1. For all hours worked over eight (8) hours in one day or shift.
2. For any hours worked on Saturday from midnight to midnight.

Double the regular straight time hourly rate shall be paid for all time:

1. For all hours worked over twelve (12) hours in one day or shift.
2. For any hours worked on Sunday from midnight to midnight.
3. For any hours worked on holidays from midnight to midnight.

RECOGNIZED HOLIDAYS

If any of these holidays fall on Sunday, the Monday following shall be considered a Holiday. New Year’s Day, President’s Day, Memorial Day, Fourth of July, Labor Day, Admission Day, Thanksgiving Day, Day after Thanksgiving Day, Christmas Day.

JOB DESCRIPTION

FLAG PERSON, includes but is not limited to:

1. Directing movement of vehicular traffic through construction projects;
2. Distributing traffic control signs and markers along site in designated pattern;
3. Informing drivers of detour routes through construction sites;

Craft: FLOOR COVERER (Union Rate)

Prevailing wage rates include the base rate as well as all applicable fringes

Floor Coverer Journeyman.....	57.40
Floor Coverer Foreman.....	61.14

ADD PREMIUM PAY

Any work performed over eight (8) hours per day and on Saturdays shall be compensated at time and one-half (1-1/2x) the appropriate hourly rate. All work performed on Sundays, holidays and over twelve (12) hours in one (1) day shall be compensated at two times (2x) the appropriate hourly rate. In the event a day's work is lost because of severe weather conditions or major mechanical breakdown, work may be performed on a voluntary basis on a Saturday at the straight time hourly rate for eight (8) hours provided the straight time hours worked in one (1) week do not exceed forty (40) hours.

RECOGNIZED HOLIDAYS

New Year's Day, Memorial Day, Independence Day, Labor Day, Admissions Day, Thanksgiving Day, Day after Thanksgiving Day, Christmas Day.

JOB DESCRIPTION: Excerpt from Southwest Mountain States Regional Council of Carpenters.

All work in connection with the installation of floor coverings (with the exception of wood floors which are covered by the Master Labor Agreement) such as measuring, cutting, installing, or removal and other preparation for installation of all types of floor covering. All types of floor covering regardless of material (except wood flooring), including but not limited to all types of carpeting, linoleum, vinyl, cork, laminate floors; glue down wood floor applications; rubber, cork, asphalt, linoleum or other types of tile; artificial turf and sports surfaces; any type of resilient flooring such as epoxy, polyurethane or similar materials regardless of how applied; and ceramic tile and stone. Included in the work covered is the application or installation of any type of moisture barrier and any type of underlayment or subfloor in connection with a flooring installation.

Craft: GLAZIER (Union Rate)

Prevailing wage rates include the base rate as well as all applicable fringes

Glazier Journeyman.....	33.70
Glazier Foreman.....	36.15
Glazier Superintendent.....	37.37

ADD PREMIUM PAY

One and one half (1 ½) the regular straight time hourly rate shall be paid:

1. For first two (2) hours worked over eight (8) on a regular five (5) day week.
2. For all hours worked on Saturday. Employees shall not work less than four (4) hours.

Double the regular straight time hourly rate shall be paid for all time:

1. For all hours worked beyond ten (10) hours shall be paid at two (2 X) times the straight time rate.
2. For all hours worked on Saturday beyond 8 hours (2 X) times the straight time rate.
3. For hours worked Sunday and Recognized Holidays. Employees shall not be employed for less than four (4) hours.

*Also, if there is less than 10 hours between shifts, the 2nd shift becomes an extension of the 1st shift.

*Shift Differential: To be paid for all work performed between the hours of 5:30 pm to 5 am and it will be compensated at 10% differential for all hours worked including overtime. Overtime that falls between these hours will still be paid at the appropriate overtime rate.

20.1 High Pay – work that is thirty (30) or more feet in height above grade on an elevated, mechanically operated platform (including but not limited to: swing stage, boatswain chair, crane basket, heck lift, boom lift), rappelling work, work at slab edge outside the perimeter safety cable or work at slab edge inside the perimeter safety cable if the work being performed puts the employee in a free fall situation because the perimeter safety cable is no longer at or near waist level shall be paid at the rate of one dollar (\$1.00) per hour above the straight time rate for actual hours worked. High time shall be paid in addition to all other premiums involved.

25.2 Foremen:

a) The selection of the individual to act as foreman shall be at the discretion of the Employer. On outside jobs lasting three (3) days or more and which four (4) workers or more are employed, one (1) foreman will be designated and he shall be paid ten percent (10%) per hour over the highest journeyman Glazier supervised. Inside foreman shall receive ten percent (10%) per hour above the journeyman’s wage scale.

b) When a glazier is requested to perform welding on the job site, he/she will be compensated one dollar (\$1.00) over his regular rate of pay. All equipment, including hoods, leather and gloves, will be supplied by the Employer.

RECOGNIZED HOLIDAYS

New Year’s Day, President’s Day, Memorial Day, Independence Day, Labor Day, Veteran’s Day, Thanksgiving Day, Day after Thanksgiving Day, Christmas Day.

JOB DESCRIPTION: Excerpt from Agreement between DC 16 and Glazing Contractors Associations of NV and Independent Contractors

General Glazing shall include the layout and setting by hand or with machines, cutting, preparing handling or removal of the following and incidental and supplemental to such work: setter of art glass, prism glass, beveled glass, leaded glass, automobile glass, window glass, mirrors of all types, wire glass, ribbed glass, ground glass, colored glass, figured glass, vitrolite glass, carrara glass, and all other types of opaque glass; glass chalk boards, structural glass, tempered and laminated glass, thiokal, neoprene and all other types of glass cements, all types of insulating glass units, solar heat collectors containing glass or glass substitutes, glass hand rail, electric glass, bathroom fixtures, all plastics when used in place of glass, all other similar materials when used in place of moldings, tubber, lead and all types of mastic in wood, iron, aluminum or sheet metal, sash skylights, doors, frames, stone, wall cases, show cases, books cases, sideboards, partitions, automatic doors, automatic sliding doors, revolving doors, luminous ceilings, gaskets, and plastic mirrors, the installation of the above materials, temporary or permanent, on or for any building in the course of repair, remodel, construction or alteration.

The installation of all glass framing or support systems for the same such as extruded, rolled or fabricated metals or any materials that replace the same, such as plastics, metal tubes, mullions, metal facing materials, muttins, facia trim moldings, porcelain panels, skylights, showcase doors and relative materials, including those in any or all of the buildings related to the store front and window wall, curtain wall, stop wall, skylight and dome construction. Glazing and installation of door and window frames, such as patio sliding or fixed doors, vented or fixed windows, shower doors, bath tub enclosures, screens storm stash where the glass becomes an integral part of the finished products, the tinting and coating of glass for the reflecting of heat and light, showcase tops, glass shelving of all types and table tops. In addition, such caulking, glass to glass, glass to metal, metal to concrete and panel to panels.

Production, maintenance, including all incidental and supplemental to, but not limited to Employees, and Employees who are engages int eh cutting, preparing, handling and selecting of glass and /or mirror, bevellers, silverers, blockers, scratch polishers, sand-blasters, flat glass wheel cutters, miters cutters, engraver, hole-drilling machine operations, belt sanding, automatic beveling, multi-grove edging machines, semi- and automatic-cutting machines, grinding, polishing unpacking ad racking or glass, glass packing, glass and mirror cleaning, mirror stripping, all operations in the manufacturing, framing and fabrication and assembling of all insulating units, assembling of all glass insulated solar heat collectors containing glass or glass substitutes, molding or mirrors, manufactured and assembly of sliding glass or mirror doors, the operating of all machines and equipment for these operations, oven operations, glass hangers, glass benders and operators, safety glass fabricators, inspectors, janitors, maintenance mechanics, loading and unloading or truck and railroad cars.

Craft: Highway Striper (Union Rate)

Prevailing wage rates include the base rate as well as all applicable fringes

Highway Striper.....	51.28
Highway Striper Foreman.....	51.78

ADD ZONE RATE

In addition to HIGHWAY STRIPER rates add the applicable amounts per hour, calculated based on a road miles from either the Carson City Courthouse or the Washoe County Courthouse:

Zone 1	0 to 75 miles	\$0.00
Zone 2	75 to 150 miles	\$6.00
Zone 3	150 to 300 miles	\$7.00
Zone 4	300 miles or over	\$8.00

ADD PREMIUM PAY

One and one half (1 ½) the regular straight time hourly rate shall be paid:

1. For all hours worked over eight (8) hours in one day or shift.
2. For any hours worked on Saturday from midn ight to midnight.

Double the regular straight time hourly rate shall be paid for all time:

1. For all hours worked over twelve (12) hours in one day or shift.
2. For any hours worked on Sunday from midnight to midnight.
3. For any hours worked on holidays from midnight to midnight.

RECOGNIZED HOLIDAYS

If any of these holidays fall on Sunday, the Monday following shall be considered a Holiday.

New Year’s Day, Memorial Day, 4th of July, Labor Day, Admission Day, Thanksgiving Day, Day after Thanksgiving Day, Christmas Day.

JOB DESCRIPTION:

Includes but is not limited to:

1. Painting highways, streets and parking surfaces by using manually propelled or mechanically propelled machines, brushes, rollers or spray guns;
2. Installing any device or application of any material used in lieu of paint for traffic direction, including, without limitation, buttons, tapes, plastics, rumble bars and other similar materials;

Craft: Hod Carrier-Brick Mason Tender (Union Rate)

Prevailing wage rates include the base rate as well as all applicable fringes

Brick Mason Journeyman.....	49.03
Brick Mason Foreman.....	49.43

ADD ZONE RATE

In addition to Hod Carrier Brick Mason Tender rates add the applicable amounts per hour, calculated based on road miles from either the Carson City Courthouse or the Washoe County Courthouse:

Zone Rate	75 miles and over	\$8.13
-----------	-------------------	--------

ADD PREMIUM PAY

One and one half (1 ½) the regular straight time hourly rate shall be paid:

1. For all hours worked over eight (8) hours in one day or shift.
2. For any hours worked on Saturday from midnight to midnight.

Double the regular straight time hourly rate shall be paid for all time:

1. For all hours worked over twelve (12) hours in one day or shift.
2. For any hours worked on Sunday from midnight to midnight.
3. For any hours worked on holidays from midnight to midnight.

RECOGNIZED HOLIDAYS

If any of these holidays fall on Sunday, the Monday following shall be considered a Holiday.

New Year's Day, President's Day, Memorial Day, Fourth of July, Labor Day, Admission Day, Thanksgiving Day, Day after Thanksgiving Day, Christmas Day.

JOB DESCRIPTION: Excerpt from Agreement between No, NV Masonry Contractors and LIUNA Local 169

Conveying of all materials used by the Brick and Stone Masons from the first point of delivery to the Mechanic whether done manually or by a piece of machinery or equipment devised to replace the wheelbarrow or buggy, including but not limited to the forklift. The handling of Bricks, Blocks, mortar, or any other material to serve the bricklayer in any capacity building and dismantling scaffolds of any kind or type used by Bricklayers for masonry work including but not limited to tower scaffolds, access scaffolds, or other specialty scaffolds, mixing and tempering mortar by hand and/or machine, mixing grout and cleaning up after the bricklayer, the repairing and maintenance of all equipment, either on the job or in the yard.

Craft: Hod Carrier-Plasterer Tender (Union Rate)

Prevailing wage rates include the base rate as well as all applicable fringes

Plasterer Tender-Journeyman.....	49.37
Plasterer Tender- Gun Tender.....	50.37
Plasterer Tender-Foreman.....	50.73

ADD ZONE RATE

In addition to: HOD CARRIER-PLASTERER TENDER rates add the applicable amounts per hour, calculated based on road miles from either the Carson City Courthouse or the Washoe County Courthouse:

Zone Rate	75 miles and over	\$8.00
-----------	-------------------	--------

ADD PREMIUM PAY

One and one half (1 ½) the regular straight time hourly rate shall be paid:

1. For all hours worked over eight (8) hours in one day or shift.
2. For any hours worked on Saturday from mid night to midnight.

Double the regular straight time hourly rate shall be paid for all time:

1. For all hours worked over twelve (12) hours in one day or shift.
2. For any hours worked on Sunday from midnight to midnight.
3. For any hours worked on holidays from midnight to midnight.

RECOGNIZED HOLIDAYS

If any of these holidays fall on Sunday, the Monday following shall be considered a Holiday. New Year’s Day, President’s Day, Memorial Day, Fourth of July, Labor Day, Admission Day, Thanksgiving Day, Day after Thanksgiving Day, Christmas Day.

JOB DESCRIPTION: Excerpt from Agreement between Plasterers Contractors and LIUNA Local Union 169

Any Employee within the scope of this division tending or serving any other worker performing plasterers work, any plasterer, plasterers, or apprentices in any capacity performing plasterers work including but not limited to, handling and conveying of all materials after delivery used by plasters, including but not limited to, inside finish coat, outside finish coat, brown coat, scratch coat, sprayed or trawled on fireproofing, EIFS systems, and other materials or systems for the same or similar purpose whether done manually or by a piece of machinery or equipment devised to replace the wheelbarrow or buggy, including but not limited to the forklift, tusky hoist, and rigging and signaling for cranes to the point or points of application or installation, making mixing and preparing after delivery all materials used by plasters, whether by hand or machine including but not limited to mixers, pumps for plaster or fire proofing, plaster, finish coats, fireproofing, including Monocoat, Cafco or other materials for the same or similar use, moving any rolling scaffolding, building and handling all necessary trestle, scaffolding and planking of scaffolding for plasterers and lathers, building mortar boxes, mortar boards and stands, and the repairing and maintenance of all equipment either on the job or in the yard, the spreading of all temporary protective drop cloths, building paper or plastic covers and taping of same (in a composite crew with the plasterers when necessary), the cleaning of all floors, and debris, behind the plasterers or any other worker performing plasterers work in connection with the work performed all work necessary for cold weather protection and cure including but not limited to handling installing or tending to blankets, visqueen, and space heaters, and running putty.

Tending to plasterers or any other worker performing plasterers work on EFIS system work shall include all work after the wallboard is installed including but not limited to any preparatory sealing or leveling, placing foam, mesh, and plaster including any rough, finish, and color coats.

For sprayed on fire proofing work only, including Monocoat, Cafco or other materials for the same or similar use an Employer signatory to this Agreement and the Local 169, Laborers Master Agreement may employ Laborers at the Group 1 wage rate to perform overspray protection, the spreading of all temporary protective drop cloths, building paper or plastic covers and taping of same, the cleaning of all floors, and debris, cold weather protection and cure including but not limited to handling installing or tending to blankets, visqueen, and space heaters and moving rolling scaffolding.

Craft: Ironworker (Union Rate)

Prevailing wage rates include the base rate as well as all applicable fringes

SEE AMENDMENT 2

Ironworker-Journeyman.....	81.01
Ironworker - Foreman.....	85.63
Ironworker -General Foreman.....	90.71

ADD ZONE RATE

In addition to Iron Worker rates add the applicable amounts per day, calculated based on a road mile from the Reno City Hall or Las Vegas City Hall.

Zone 1	60 to 75 miles	\$20.00
Zone 2	75 to 100 miles	\$25.00
Zone 3	100 miles and over	\$75.00

ADD PREMIUM PAY

One and one half (1X) the regular straight time hourly rate shall be paid:

1. For the first two (2) hours worked in excess of eight (8) on a regular workday Monday-Friday
2. For the first eight (8) hours on Saturday

Double the regular straight time hourly rate shall be paid for all time:

1. For all hours worked over ten (10) hours in one day or shift.
2. For any hours worked on Sunday.
3. For all hours worked over eight (8) on Saturday
4. For all hours worked on Holidays

Shift Pay

1. 2nd shift add 6% of hourly wage
2. 3rd shift add 13% of hourly wage
3. Dedicated shift add 6% of hourly wage

RECOGNIZED HOLIDAYS

New Year's Day, President's Day, Memorial Day, Independence Day, Labor Day, Thanksgiving Day, Day after Thanksgiving Day, Christmas Day.

JOB CLASSIFICATION: Excerpt from Agreement between NV AGC and DC of Ironworkers

Field fabrication and/or erection or deconstruction of structural, ornamental and reinforcing steel, including but not limited to the fabrication, rigging and signaling, erection and construction of all iron and steel, ornamental lead, bronze, brass, copper and aluminum, plastics and all other substitute materials, including, but not limited to, composites, carbon fiber and fiberglass, all barrier railings, handrail, aluminum, steel, glass and plastic, reinforced concrete structures or parts thereof; bridges, viaducts, inclines, dams, docks, dredges, vessels, locks, gates, guides, aqueducts, reservoirs, spillways, flumes, caissons, cofferdams, subways, tunnels, cableways, tramways, monorails, blast furnaces, stoves, kilns, coolers, crushers, agitators, pulverizers, mixers, concentrators, ovens, cupolas, roof decking such as but not limited to "Cofar", "Trusdeck", Mahon "M"; smoke conveyors, penstocks, flag poles, drums, shafting, shoring, fur and storage rooms, fans and hot rooms, stacks, bunkers, conveyors, dumpers, elevators, vats, tanks, enamel tanks, enamel vats, towers, pans, hoppers, plates, anchors, caps, corbels, lintels, Howe and combination trusses, grillage and foundation work, grating, bucks, partitions, hanging ceilings, hangers, clips, brackets, flooring, floor construction and domes, rolling shutters, curtains, frames; aluminum, rolling fire, won and iron doors,

including supports; cast tiling, air ducts, duct and trench frames and plates; wire work, railings, wire cable including pipe, guards, fencing, grill work, sidewalk and vault lights, skylights, roofs, canopies, light steel framing, marquees, awnings and other related equipment elevator and dumb waiter enclosures, elevator cars, tracks, fascias, aprons, operating devices, steel and aluminum sash, hardware and screens, frames, fronts, lockers, racks, book stacks, tables, shelving, metal furniture, seats, chutes, escalators, stairways including pre-engineered stairs, ventilators, boxes, fire escapes, signs, jail and cell work, safes, vaults, vault doors, safe deposit boxes, corrugated sheets when attached to steel frames, including insulation; frames in support of boilers; materials altered in field such as framing, cutting, bending, drilling, burning and welding including by acetylene gas and electric machines; metal forms and false work pertaining to concrete construction; seismic isolation systems and dampening systems including base isolators, sectional water tube and tubular boilers and stokers; traveling sheaves, vertical hydraulic elevators, bulkheads, skip hoists, making and installation of articles made of wire and fibrous rope, rigging in connection with pumps, compressors, forced and induced draft fans, air meters, Bailey meters, agitators, oxygen converters, cinder machines, pelletizing machines, reactor vessels, reactor spheres, completed tanks and assembled sections of completed tanks, scroll cases, refineries, hydroelectric power houses and steam plants, cogeneration plants, vessels and government departments; false work, travelers, scaffolding, pile drivers, sheet piling, derricks and powered derrick swinger including the erection, installation, handling and operating. Cranes erection, installation, handling and operating of same on all forms and types of construction work. The operation of Valla and Spider type battery and/or propane powered portable floor cranes having no operator seat utilized to install ironworker scope of work and the same on all forms and types of construction work. Crane work at the ports, including hammer-head cranes, container cranes and rubber tire cranes. Offloading, relocations, and commissioning of all burning and removal of sea bracing track layout; erection of apex boom extensions, back reach extensions, and rail replacement. Includes all welding, containment and structural modifications of the aforementioned items; railroad bridge work including maintenance thereof; moving, hoisting and lowering of machinery, modules, skid modules and placing of same on foundation, including bridges, cranes, intermittent use forklifts, derricks, buildings, piers and vessels; loading, unloading, necessary maintenance, erection, installation, removal, wrecking and dismantling of all of the above and all reinforcing work and submarine diving in connection with or about same; erection of steel towers, chutes and spouts for concrete where attached to towers and handling and fastening of cables and guys for same; unloading, racking, sorting, cutting, bending, hoisting, placing and tying including the use of any and all mechanical tying devices, burning and welding including stud welding of all iron, steel and metal in reinforced concrete construction including mesh for floor arches and the making of hoops and stirrups, metal forms and metal supports thereof; jacking of slip forms, installation of all wire, cable, parabolic cans, steel and all other materials, including, but not limited to, composites, carbon fiber and fiberglass, used for the purposes of prestressing including grouting of ducts, post stressing concrete girders, beams, columns, etc.; loading, unloading, hoisting, handling, signaling, placing and erection of all prestressed, post stressed, precast materials, G.F.R.C., Dryvit System, including the securing by bolting and/or welding and the installation of steeltex and wire mesh of any type when used for reinforced concrete construction; erection of all curtain wall; glass handrail; stay in place deck; automated and/or mechanical parking structures; offloading, staging, hoisting and setting of modular structures and micro-units; curtain wall systems and associated sealants. Window wall and entrances, panels, insulated and non-insulated, factory and field assembled, porcelain enameled panels, ceramic, laminated spandrelite, louvers and sunscreens; application of thiokol, neoprene and other sealants used to seal materials installed by Iron Workers; installation and handling of phenolic panels, including but not limited to, Trespa products and all similarly related materials and/or systems; installation of metal window stools and sills; installation of aluminum, bronze and steel thresholds; erection and dismantling of all types of cranes and changing of booms; erection of rock, sand and gravel plants, dismantling and loading out conveyors, aggregate plants, batch plants, ableways, refrigeration plants, etc.; erection and dismantling of Monigan walking dragline, launchhammer bucket wheel excavator and other trenching equipment; signaling on highlines, whirley cranes and derricks, buck hoists, man hoists, fork lifts, material towers and scanning antennae; metal and steel supports of all types; fabrication, assembling and erection of offshore drilling platforms or similar installations; dust collectors, precipitators, multi-plate, specialty welding

processes, unloading, loading, hoisting, handling and rigging of all building materials delivered to the job site; hanging ceilings, tees, channels, beams, acoustical elements, sound barriers, computer floors, etc.; installation of stage rigging (including counterweights), curtains, draperies, traverse rods, tracks, cables, window cleaning equipment, powered work platforms, including and loading and unloading, erection installation and removal of powered chassis mounted elevating mast climbing work platforms, rigging in connection with display shows; ski lifts, etc.; wrecking of bridges, viaducts, elevated roads and structural steel and iron in buildings; all steel frames for openings, all porches, verandas, canopies and balconies; all overhead travelers, duo rails, tram rails; erection, setting, repairing of guard or collision rails on bridges and approaches, road ways or any other structures; handling and setting of all types of steel and metal joists, including metal box joists for truss lab and preformed keystone shaped metal joists; erection of steel and metal houses and packaged buildings; all translucent and plastic material on steel frame construction; the erection of solar energy systems, including but not limited to, photo voltaic, heliostat and parabolic systems, energy producing windmill type towers, wind turbine erection to included, but not limited to, prep work, boltup, tensioning or torque of bolts on base and all tower section turbine and blade assemblies; nuclear reactors, electromagnetic shielding plates and atomic vessels including all component parts; the plumbing, aligning and leveling of all materials and equipment through the use of optical instruments, LASER beams, etc., and the use of instruments to establish layout, installation and disposition of ironworker installed scope of work; the unloading, distributing, stockpiling and handling of all materials coming under the jurisdictional claims of the UNION such as to rail heads, storage yards, loading and unloading, hoisting, handling, signaling of all fabricated material and equipment at the jobsite (except FOB deliveries) related to the Iron Workers jurisdiction that is within the individual employers' contractual scope of work including from and to barge and ships to a lay down yard or construction project, etc., shall be done by the Iron Workers.

All reinforcing work in connection with field fabrication, including but not limited to the pre-assembly of reinforcing cages, loading and unloading, handling, racking, sorting, cutting, bending, hoisting, intermittent use of forklifts, placing, burning, welding and tying of all material including the use of any and all mechanical tying devices, or substitute materials, including but not limited to, composites, carbon fiber and fiberglass, stainless steel, used to reinforce concrete construction shall be done by Iron Workers within the individual employers' scope of work at the jobsite, excluding FOB deliveries. A working Iron Worker shall be employed for maintenance on jobs of substantial size while concrete is being poured on reinforcing steel, wire mesh and paper back steeltex but will not be required as a stand-by man. All work in connection with the installation, alignment, repair & modification of panelized roofing systems, pre-engineered fabric structures, aluminum clarifier coverings, carports, ministorages, and dock planks. All work in connection with the installation, alignment, repair and modification of bleachers, planking and stadium seating. All work in connection of installation of amusement rides including, but not limited to, the erection and alignment of all track, machinery and related components.

Craft: Laborer (Union Rate)

Prevailing wage rates include the base rate as well as all applicable fringes

Landscaper	43.37
Furniture Mover	44.87
Group 1.....	48.53
Group 1A.....	46.66
Group 2.....	48.63
Group 3.....	48.78
Group 3A.....	52.21
Group 4.....	49.03
Group 4A.....	51.53
Group 5.....	49.33
Group 6	
Nozzlemen, Rodmen.....	48.33
Gunmen, Materialmen.....	48.33
Reboundmen.....	48.68
Gunite Foreman.....	49.73

ADD ZONE RATE

In addition to LABORER rates add the applicable amounts per hour, calculated based on a road miles from either the Carson City Courthouse or the Washoe County Courthouse:

Zone 1	0 to 75 miles	\$0.00
Zone 2	75 to 150 miles	\$6.00
Zone 3	150 to 300 miles	\$7.00
Zone 4	300 miles or over	\$8.00

ADD PREMIUM PAY

One and one half (1 ½) the regular straight time hourly rate shall be paid:

1. For all hours worked over eight (8) hours in one day or shift.
2. For any hours worked on Saturday from midn ight to midnight.

Double the regular straight time hourly rate shall be paid for all time:

1. For all hours worked over twelve (12) hours in one day or shift.
2. For any hours worked on Sunday from midnight to midnight.
3. For any hours worked on holidays from midnight to midnight.

RECOGNIZED HOLIDAYS

If any of these holidays fall on Sunday, the Monday following shall be considered a Holiday. New Year’s Day, President’s Day, Memorial Day, Fourth of July, Labor Day, Admission Day, Thanksgiving Day, Day after Thanksgiving Day, Christmas Day.

JOB DESCRIPTION: Excerpt from Agreement between AGC and LIUNA Local 169

The construction, erection, alteration, repair, modification, demolition, addition, improvement of all building, heavy and highway, utility, industrial and all other type(s) of construction.

SEE GROUP CLASSIFICATIONS

Craft: LUBRICATION AND SERVICE ENGINEER (MOBILE AND GREASE RACK) (Union Rate)

Prevailing wage rates include the base rate as well as all applicable fringes

SEE AMENDMENT 3

Lubrication and Service Engineer (mobile and grease rack).....71.43

ADD ZONE RATE

In addition to: **LUBRICATION AND SERVICE ENGINEER (MOBILE AND GREASE RACK)** rates add the applicable amounts per hour calculated based on a road miles from the Carson City Courthouse or Washoe County Courthouse.

Zone 1	0 to 75 miles	\$0.00
Zone 2	75 to 150 miles	\$5.00
Zone 3	150 to 300 miles	\$6.00
Zone 4	300 miles and over	\$7.00

ADD PREMIUM PAY

1. One and one-half (1-1/2) times the applicable straight-time rate for the day, shift, work, equipment and classification shall be paid for all work (including repair work and field survey work) performed on Saturday and before a shift begins and after it ends, except when operating equipment servicing a craft that is receiving double time on commercial building construction, in which case double time shall be paid.
2. Overtime. The following rates shall apply on Sundays and holidays and all work before a shift begins and after it ends:

RECOGNIZED HOLIDAYS

Holidays. Double the applicable straight-time rate shall be paid for all work (including repair, maintenance and field survey work) performed on Sundays and the following holidays: New Year's Day (January 1); Memorial Day (last Monday in May); Independence Day (July 4); Labor Day (1st Monday in September); Nevada Admission Day (last Friday in October); Thanksgiving Day (4th Thursday in November); the day after Thanksgiving Day; and Christmas Day (December 25). Holidays falling on Sunday shall be observed on the following Monday. Holiday hours shall be reckoned on the same basis as Sunday hours.

Saturday Shift Period. On any shift, Saturday shall be the twenty-four-hour period commencing at 12:00 midnight Friday.

Sunday Shift Period. On any shift, Sunday shall be the twenty-four-hour period commencing at 12:00 midnight Saturday.

3. For hours worked in excess of 12) on any such workday, an Employee shall be paid two (2) times the regular straight-time rate of pay for each hour so worked.

Craft: Mechanical Insulator (Union Rate)

Prevailing wage rates include the base rate as well as all applicable fringes

Mechanical Insulator-Mechanic.....	75.52
Mechanical Insulator-Foreman.....	79.52
Mechanical Insulator-General Foreman	81.52

ADD ZONE RATE

In addition to MECHANICAL INSULATOR rates add the applicable amounts per DAY, calculated based on a radius figured from Reno City Hall:

Zone 1	0 to 20 miles	\$15.00
Zone 2	21 to 40 miles	\$25.00
Zone 3	41 to 60 miles	\$35.00
Zone 4	Over 60 miles	\$100.00
Zone 4: Up to \$140.00 per day with receipts		

ADD PREMIUM PAY

One and one half times the minimum hourly wage rate shall be paid for the first two (2) hours of overtime work, directly following eight (8) hours Monday through Friday, and for the first ten (10) hours worked on Saturdays. Double the minimum hourly wage rate shall be paid for all other overtime worked Monday through Friday and in excess of ten (10) hours on Saturdays.

RECOGNIZED HOLIDAYS

New Year's Day, President's Day, Good Friday, Memorial Day, Independence Day, Labor Day, Veteran's Day, Thanksgiving Day, Day after Thanksgiving Day, Christmas Day.

JOB DESCRIPTION: Excerpt from the Int'l Assoc. of Heat and Frost Insulators and Allied Workers Local 16 and the No. CA Chapter. Western Insulation Contractors Assoc.

- 65. Lining of all mechanical room surfaces and air handling shafts.
- 66. The filling and damming of fire stops and penetrations including, but not limited to, electrical and mechanical systems.
- 67. All foam applications for the purpose of thermal, acoustical, or fire protective purposes, including RTV foams or equivalents, applied to mechanical or electrical systems.
- 68. All duct lining, and duct wrapping, done on the job site, direct application and installation of fire protection of grease ducts, exhaust systems, or any other ductwork for acoustical or thermal purposes.
- 69. The insulation of all field joints on pre-insulated underground piping, and the pouring of Gilsilite or its equivalent.
- 70. Any finish material which is contiguous to the thermal or acoustical application.
- 71. The preparation, distribution of materials on job sites, assembling, molding, spraying, pouring, mixing, hanging, adjusting, repairing, dismantling, reconditioning, maintaining, finishing, and weather proofing of hot or cold thermal or acoustical insulation with such materials as may be specified.
- 72. The application of any material, including metal and PVC jacketing, Alumaguard or equivalent, on piping, fittings, valves, flanges, boilers, ducts, plenums, flues, tanks, vats, equipment and any other hot or cold surface for the purpose of thermal control.
- 73. The Agreement shall cover all other work of a specialty nature.

Craft: MILLWRIGHT (Union Rate)

Prevailing wage rates include the base rate as well as all applicable fringes

Millwright Journeyman.....	73.97
Millwright Welder.....	76.97
Millwright Foreman.....	78.46
Millwright General Foreman.....	83.40

ADD ZONE RATE

In addition to MILLWRIGHT rates add the applicable amounts per hour, calculated from Reno, Nevada City Hall. The Employer agrees to provide each employee zone pay as established below if the project is further than forty-five (45) miles calculated via the "shortest route" filter using Google Maps from the address of city hall of respective dispatch points.

Zone 1	Up to 45 Miles	\$0.00
Zone 2	More than 45 miles but less than 101 Miles	\$4.00
Zone 3	101 or more Miles	\$6.00

ADD PREMIUM PAY

Monday through Friday, the first four (4) hours of overtime after eight (8) hours of straight-time work shall be paid at one and one half (1½) times the straight-time rate of pay. All additional overtime will be paid at two (2) times the straight-time rate of pay.

All work performed on Sunday and Holidays shall be paid at two (2) times the straight-time rate of pay. Any work performed on Labor Day shall be paid at triple (3x) the regular straight time hourly wage rate.

Lodging: If the project is further than forty-five (45) miles calculated via the "shortest route" filter using Google Maps from the address of city hall of the respective dispatch points listed above, the Employer agrees to furnish acceptable single occupancy lodging to each employee. Employers are encouraged to use commercial facilities and lodges, however, when such facilities are not available, per diem in lieu of room and lodging shall be paid at the rate of one hundred ten dollars (\$110.00) per day, or part thereof, from the date of hire for the project to the date of termination of employment on the project.

RECOGNIZED HOLIDAYS

New Year's Day, Washington's Birthday (President's Day), Memorial Day, 4th of July, Labor Day, Veteran's Day, Thanksgiving Day, Friday after Thanksgiving, Christmas Day.

JOB DESCRIPTION Excerpt from Southwest Regional Council of Carpenters' Millwright Regional Master Construction Agreement.

Section 1.4 Millwright Jurisdiction.

The machinery, equipment, processes and associated components listed below which are identified for the purpose of description only, falls within the jurisdiction of the United Brotherhood of Carpenters and Joiners of America (Millwrights). Although some components of machinery and/or equipment may be described in one application or location and not in another, it shall not be excluded from our craft jurisdiction when, to avoid repetition, it is not described in other applications, and such jurisdiction shall be applied to the initial commissioning, maintenance, decommissioning, and recommissioning of all associated machinery and/or equipment.

Section 1.4.1

Millwright craft jurisdiction shall include the loading, unloading, hoisting, rigging by any means, transferring, moving, cleaning, disassembling, assembling, moving and setting and removal of skids, welding, burning, erecting, calibrating, precision grouting, supporting, aligning, starting-up and testing, adjusting, repairing, and the maintaining of all machinery and equipment, be it powered by, or receiving power from, steam, gas, gasoline, diesel, biodiesel,

hydrogen, jet, electric, pneumatic, magnetism, adiabatics, diabatics, isothermics, water, hydroprnuematics, solar, thermal, mineral, atomic, rocket, nuclear, chemical, wind, waste product of any kind or any other source, regardless of whether or not such machinery or equipment is temporarily or permanently installed or located.

Section 1.4.2

Millwright craft jurisdiction shall include all activities necessary to: set all engines, motors, dynamos, generators, diesel generators, motor restraints and supports; install, measure and align with optical and/or electronic instruments when necessary the reactors, control, push and shut-down rods, rod pressure housing, drives, guide sleeves and other related equipment in reactors, turbines, castings, combustion chambers and all its related components; the attachment and final connection of the inlet manifolds and exhaust ducts, cylinders, diaphragms, gaskets, containment barriers, rotors, blade rings, blade or bucket assemblies, hydrogen coolers, blower assemblies, packing joints on hydrogen coolers, exciter or Alterex and all others, turning gear, extension box, welding of extension box, lagging, stretching of coupling bolts or others; perform oil flush; install turbine lube oil tank, pumps and related component skids, filters, thrust bearings, magnetic bearings, the sweating on and shrinking of bearings, couplings, shafts and others, sole plates and machine bases; perform all precision grouting using the following materials: epoxy, wet, non-shrink, dripacking or other types; perform demineralizing and hydromation; install mechanical dust systems, sensors, air compressors, super charges, coolers, boiler controls and linkage, thermal management systems, Bailey Meters or similar devices and their linkages; installation, maintenance and removal of all instrumentation, gauges, antennae and other communication devices, fluid drives, power drive trains, embedded guides for traveling screens, traveling screens, roller, slide, knife, lock and sluice gates, limit torques on mechanical valves, gates and others, tainter valves, limit switches, trips, triggers or switches, including the brackets that are attached to, stop logs, dam rollers, transfer cars and gear head motors.

Section 1.4.3

The setting of variable drives, fans, coal cranes, truck cranes or other types, including servicing and the adjusting and aligning of mechanical equipment within the cranes, crane rails and all other types of rails which would carry mechanically activated equipment, including their alignment, installation, removal, servicing, and alignment of hydraulic and pneumatic lifts and passenger boarding bridges, monorail (all sizes), magnetic propulsion systems, trolleys, pumps and their associated components, packaging equipment, refrigerating equipment, chillers, and related equipment, lantern rings, packing glands, packing for pumps, pollution equipment, carbon absorbers and filtration, heat exchanges, grain, ball, hammer, roller mills, pulverizers and others, crushers and beaters, hoppers, bins, chutes and spouts, turn tables, shears, casing machines, robots, air-veyors, conveyors of all sizes, types, and styles regardless of the materials they are constructed with, or mechanically powered conveyances of any type, including their supports, people movers, x-ray and imaging & scanning machines, elevator and platform lifts, dock levelers and locks, roll-up and sectional doors, operable partitions, retractable roofs, magnetic separators, hoists, feeding machinery, Z-loaders, S-loaders, palletizers, Triax equipment, mechanical equipment in scrubbers, pack towers, precipitators, cooling towers and air cooled condensers.

Section 1.4.4

Sewage, Brackish, Desalination, Water Treatment and Mineral Extraction Plants — the disassembly, fabricating, rigging, erecting and aligning of skimmers, rake mechanisms, feed wells, baffles, scum troughs, de-gritting equipment, bar screens, communitors, mixers, pumps, aeration systems, blowers, membrane filtration systems, sequencing batch reaction systems, including related, filter presses, sand filtration systems, ultra violet rack systems, mechanical drive assemblies, conveyors, lines, piping, flanges, brackets, supports, mono rails, gates and setting odor control and detection equipment, (excluding heating, ventilating and air conditioning work). The setting of thru-clean bar, straight line bar, trash, tritor drum, and disc screens, straight line grit, circuline grit, circuline sludge, and circuline mixer collectors, straight line, flash, horizontal slow, vertical slow, and vibra flow feeder machines, pre-aeration and settling tanks, covers for tanks, bowls and basins including stationary or mechanical covers regardless of materials, thickeners, rotoline distributors, sludge bed and settling pond cleaners, digestion systems, heaters, dyna-grind sewage screening grinders, screw pumps, spiral classifier, agitators, junk remover, hydro pulper, cooling fans, lube systems, selectifier screens, hydrosensors, fuel blowers, grizzly screens, trommels, table feeders, dryers, optical sorters, high tension separators, grip dewatering screens, flash mixer, horizontal slow mixer, vertical slow mixer, filter, cone and rotary presses, comminutors, barminutors, degreasers, rotometers, dehumidifiers, benches, pressure cleaning systems & devices, washers for cars, trucks, buses, trains, planes unmanned and autonomous vehicles and other types, hydraulic, servo and pneumatic units, shroud boxes, silencers, scales, load cells, eddy current clutches, disintegrators, dehairing machines, grain handling devices, laboratory equipment, machine shop equipment, ladle cars, stunning pens and doors and gates, activation equipment, racks, material handling platforms, access & egress platforms, catwalks,

transition pieces, the handling and installation, of pulleys, gears, fluid couplings, sheaves and fly wheels, air vacuum, worm, belt, friction, rope, magnetic, chain and gear drives that are directly or indirectly coupled to motors, belts, chains, shafts, or screws, installation of legs, boots, guards and boot tanks, all bin and diverter valves, turn hands and indicators, shafting, bearing cable sprockets, cutting of all key seats in old and new work, troughs, chippers, calenders, rolls, winders, rewinders, slitters, cutters, wrapping machines, blowers, forging machines, pneumatic, electric and hydraulic rams, servo actuators, extractors, expellers and extruders, ball and dust collectors, splicing of ropes and cables.

Millwright craft jurisdiction on energy generation facilities shall include all loading, unloading, movement, hoisting, preparation, uncrating, preparation of nacelle units prior to installation or removal, installation, setting, removal, alignment, and final torquing and tensioning of any mechanical component used in the generation of power, including any incidental wiring or piping. This shall include all aspects of power trains, drive and tracking systems, elevation and azimuth drives, energy collection optimization systems, all rams, dampers and other stabilization devices, antennae, bearing housing assemblies and units, actuators, pulleys, gears, access points, rotational connections, mounting and alignment of tracks, axles, bearings, rotational joints, or any other device which allows for the automated or manual movement of equipment post-installation, all turbines, and wind, wave and tidal analysis equipment. It shall also include all work associated with energy collection and storage facilities, including the loading, unloading, movement, hoisting, preparation, installation, setting, and alignment of racking systems, torque tubes, modules, batteries, energy storage systems, cooling or control systems, inertia systems or other equipment or machinery, and all incidental wiring or piping thereof.

Section 1.4.5

The laying out, fabrication and installation of protecting equipment including: machinery guards; the making and setting of templates for machinery; the fabrication of bolts, nuts, pans; the drilling or creating of holes in machinery for any equipment which the Millwrights install, remove, service or inspect, regardless of material; installation of all methods of access and egress and safety devices whether temporary or permanent; all welding and burning regardless of type; the fabrication of all lines, hose or tubing used in the lubrication, operation, cooling or heating of machinery, including the installation of all fluids used to operate, lubricate, cool or heat equipment installed by Millwrights; the cleaning or pressure cleaning of machinery; the machining, grinding, milling, broaching, boring, threading, lapping, field machining, technical bolting and keying that may be necessary for any part of equipment, including the starting up, breaking in, trial running and operational or functional testing of any equipment or machinery installed or handled by the Millwrights, the initial programing of robotics for startup, and the incidental connection and disconnection of machinery and equipment from piping and electrical systems.

Section 1.4.6

Rock, sand and gravel plants, mineral processing plants and batch or aggregate plants: Installation, removal and maintenance of all recycling equipment, separators, centrifuges, classifiers, grates, crushers, conveyors, chutes or piping from one piece of mechanical equipment into another piece of mechanical equipment, or from a vessel into a conveyor, or into other places or mechanical equipment or other mechanical equipment used (for the purpose of description only) to excavate material from one area to another from highways, roadways, waterways or elsewhere.

Section 1.4.7

When optical instruments such as total stations or similar devices, automatic levels, builder's transits, precision jig transits, tilting levels, theodolites or other precision tools and instruments are used to locate, set, scan-to-BIM or as-Built measure and verify machines, these tools are considered a tool of the Millwright trade and are to be used by Millwrights to set the equipment or machinery.

Section 1.4.8

Incidental asbestos removal on equipment in which Millwrights normally remove during maintenance and repair work.

Section 1.4.9

Any new equipment or technology designed to replace any of the equipment described above shall remain in the craft jurisdiction of the Millwrights.

Craft: OPERATING ENGINEER (Union Rate)

Prevailing wage rates include the base rate as well as all applicable fringes

SEE AMENDMENT 3

Operating Engineers	(SEE GROUP CLASSIFICATIONS)
Group 1.....	66.41
Group 1A.....	69.17
Group 2.....	69.70
Group 3.....	69.97
Group 4.....	70.71
Group 5.....	71.01
Group 6.....	71.18
Group 7.....	71.43
Group 8.....	72.02
Group 9.....	72.34
Group 10.....	72.69
Group 10A.....	72.88
Group 11.....	73.12
Group 11A.....	74.76
Group 11B.....	75.57
Foreman.....	74.76

Add 12.5% to base rate for "Special" Shift

Add Operating Engineers Zone Pay

Add Premium Pay

Craft: OPERATING ENGINEER (Union Rate)

STEEL FABRICATOR & ERECTOR

Prevailing wage rates include the base rate as well as all applicable fringes

SEE AMENDMENT 3

Operating Engineers	(SEE GROUP CLASSIFICATIONS)
Group 1.....	81.71
Group 1 Truck Crane Oiler.....	75.54
Group 1 Oiler.....	73.58
Group 2.....	80.20
Group 2 Truck Crane Oiler.....	75.29
Group 2 Oiler.....	73.37
Group 3.....	78.96
Group 3 Truck Crane Oiler.....	75.07
Group 3 Oiler.....	73.15
Group 3 Hydraulic.....	74.74
Group 4.....	77.23
Group 5.....	76.13

Add 12.5% to base rate for "Special" Shift

Add Operating Engineers Zone Pay

Add Premium Pay

Craft: OPERATING ENGINEER (Union Rate)
 PILEDRIVER

Prevailing wage rates include the base rate as well as all applicable fringes
SEE AMENDMENT 3

Operating Engineers	(SEE GROUP CLASSIFICATIONS)
Group 1.....	81.18
Group 1 Truck Crane Oiler.....	75.72
Group 1 Oiler.....	73.80
Group 2.....	79.64
Group 2 Truck Crane Oiler.....	75.51
Group 2 Oiler.....	73.60
Group 3.....	78.19
Group 3 Truck Crane Oiler.....	75.29
Group 3 Oiler.....	73.37
Group 4.....	76.68
Group 5.....	75.57
Group 6.....	72.29
Group 7.....	73.50
Group 8.....	72.54
Add 12.5% to base rate for "Special" Shift.....	

ADD ZONE RATE

In addition to: **OPERATING ENGINEER, STEEL FABRICATOR & ERECTOR, and OPERATING ENGINEER PILEDRIVER**, rates add the applicable amounts per hour calculated based on a road miles from the Carson City Courthouse or Washoe County Courthouse

Zone 1	0 to 75 miles	\$0.00
Zone 2	75 to 150 miles	\$5.00
Zone 3	150 to 300 miles	\$6.00
Zone 4	300 miles over	\$7.00

ADD PREMIUM PAY

1. One and one-half (1-1/2) times the applicable straight-time rate for the day, shift, work, equipment and classification shall be paid for all work (including repair work and field survey work) performed on Saturday and before a shift begins and after it ends, except when operating equipment servicing a craft that is receiving double time on commercial building construction, in which case double time shall be paid.

2. Overtime. The following rates shall apply on Sundays and holidays and all work before a shift begins and after it ends:

RECOGNIZED HOLIDAYS

Holidays. Double the applicable straight-time rate shall be paid for all work (including repair, maintenance and field survey work) performed on Sundays and the following holidays: New Year's Day (January 1); Memorial Day (last Monday in May); Independence Day (July 4); Labor Day (1st Monday in

September); Nevada Admission Day (last Friday in October); Thanksgiving Day (4th Thursday in November); the day after Thanksgiving Day; and Christmas Day (December 25). Holidays falling on Sunday shall be observed on the following Monday. Holiday hours shall be reckoned on the same basis as Sunday hours.

Saturday Shift Period. On any shift, Saturday shall be the twenty-four-hour period commencing at 12:00 midnight Friday.

Sunday Shift Period. On any shift, Sunday shall be the twenty-four-hour period commencing at 12:00 midnight Saturday.

3. For hours worked in excess of 12) on any such workday, an Employee shall be paid two (2) times the regular straight-time rate of pay for each hour so worked.

JOB DESCRIPTION, includes but is not limited to:

Operate one or several types of power construction equipment, such as motor graders, bulldozers, scrapers, compressors, pumps, derricks, shovels, tractors, or front-end loaders to excavate, move, and grade earth, erect structures, or pour concrete or other hard surface pavement.

Craft: PAINTER (Union Rate)

Prevailing wage rates include the base rate as well as all applicable fringes

Brush/Roller Painter.....	49.79
Spray Painter/Paperhanger.....	51.50
Sandblaster.....	51.55
Structural Steel & Steeplejack.....	51.55
Swing Stage.....	49.30
Special Coating Application-Brush.....	49.35
Special Coating Application-Spray.....	49.35
Special Coating Application-Spray Steel.....	53.29
Foreman.....	\$1.00 above highest Journeyman

ADD PREMIUM PAY

One and one half (1 ½) the regular straight time hourly rate shall be paid:

1. For all hours worked over eight (8) hours in one day or shift unless the Union is notified when four (4) tens (10's) are instituted.
2. For any hours worked on Saturday from midnight to midnight
3. For any work performed in excess of the regular work week of forty (40) hours.

Double the regular straight time hourly rate shall be paid for all time:

1. For any hours worked on Sunday from midnight to midnight
2. For any hours worked on holidays from midnight to midnight

RECOGNIZED HOLIDAYS

New Year's Day, President's Day, Memorial Day, Independence Day, Labor Day, Veteran's Day, Thanksgiving Day, Day after Thanksgiving Day, Christmas Day.

JOB DESCRIPTION: Excerpt from Agreement between Painters and Allied Trades DC 16 and Independent Flooring Contractors of No Nevada

a. All painting of residences, buildings, structures, industrial plants, tanks, vats, pipes, vessels, bridges, light poles, high tension poles, traffic and parking lines on highways, parking lots, playgrounds, factories, and air line strips; all sign, pictorial, coach, car automobile, carriage, aircraft machinery, ship and railroad equipment, mural and scenic painting; spackling of all surfaces where adhesive materials are used; and all drywall pointing, taping and finishing.

b. All decorators, paperhangers, hard wood finishers, grainers, glaziers, varnishers, enamellers

1. Paperhangers work shall be all material of whatever kind or quality applied to walls or ceilings with paste or adhesive; all tacking on the muslin or other materials which is used as wall or ceiling coverings or covered with material pasted on.

2. The scraping off of old paper, preparing of walls, etc., for paper hangers work.

3. The application of relief, stucco, plaster or decorative work shall not be considered paperhanger's work exclusively.

(c) All men engaged in applying or removing paints, pigments, extenders, metal primers and metal pigments, clear pigments, binders, thinners and dryers, primers and sealers, oil paints and enamels, water

colors and emulsions, clear coatings, waxes, stains, mastics, cement enamels and other special coatings, plastics, adhesives, coatings and sheet rubber and other linings, oils, varnishes, water colors, wall paper, wall coverings or other materials used in the various branches of the trade, and the cleaning and bleaching of all interior and exterior walls and surfaces with liquid, steam, sandblast or any other process and all work incidental thereto.

Craft: PILED RIVER (Union Rate)

Prevailing wage rates include the base rate as well as all applicable fringes

Piledriver-Journeyman.....	58.92
Piledriver-Welder.....	59.92
Piledriver-Foreman.....	62.61
Piledriver-General Foreman.....	66.67
Tender.....	62.61
Stand-By Diver.....	63.61
Diver-Diving (Wet Pay).....	105.18

ADD ZONE RATE

In addition to PILED RIVER rates add the applicable amounts per hour, calculated from the Washoe County Courthouse:

Zone 1	Within 75 miles	\$0.00
Zone 2	Between 75 to 150 road miles	\$6.00
Zone 3	Between 150 to 300 road miles	\$7.00
Zone 4	In excess of 300 road miles	\$8.00

Workmen performing outside of the free zones shall receive the appropriate remote area allowance for not less than eight (8) hours per day. Remote area differential shall be considered part of the basic wage rate for the purpose of computing overtime hourly wage rates.

ADD PREMIUM PAY

First two (2) hours outside the regular constituted shift shall be at the rate of time and one-half (1½X). Saturdays up to the first twelve (12) hours shall be at the rate of time and one-half (1½X). All additional hours and Sundays and holidays shall be the rate of double time (2X). No work shall be performed on Labor Day, except to preserve life and property.

RECOGNIZED HOLIDAYS

New Year's Day, Memorial Day, 4th of July, Labor Day, Admission Day, Thanksgiving Day, the Friday after Thanksgiving, Christmas Day.

JOB DESCRIPTION

104.1 The Carpenters claim the layout, rigging, tagging, signaling, cutting, burning, welding, chain sawing, driving, setting and pulling of all soldier piles and soldier beams together with all necessary waling, shoring, underpinning, struts, bracing, capping and lagging necessary for construction of subterranean structures of all types to include, but not limited to subways, subway stations, buildings, storm drains, sewers, pipelines and all open cut and cover construction projects. The Carpenters further claim construction of all covers and access mats to include all necessary rigging for setting and removing, whether intermittently or regularly and installation and removal of timber decking.

(a) In addition to the work identified in Article I, the Pile Divers claim the operation of the following types of equipment when the operation of same is incidental to that work which falls under the jurisdiction of the United Brotherhood of Carpenters and Joiners of America or Pile Drivers Local Union No. 2375; mechanical forklifts of all types, boom trucks and any other mobile equipment as assigned by the employer necessary to complete the work. In addition, the operation of the power pack and vibratory hammer controls when driving or pulling, sheet pile, pile, soldier beams, cassinos or casing. . The work includes work on cast & drill holes and operation of the ABI machine.

(1) In the construction of waterfront and marine facilities, such as docks, piers, wharves, bulkheads, jetties, and similar structures, the pile driver classification should continue to apply, up to and including the decking thereof.

- (2) On all pile driving and caisson work on both land and water, the Pile Driver classification should apply.
- (3) In the construction of wooden bridges whether over land or over water, when composed of heavy timber, the Pile Driver classification should apply.
- (4) In the construction of concrete or steel bridges over land, the Pile Driver classification shall apply to the driving of piles and/or caisson work including the forms required for the capping of the piles or caissons immediately top of the piles or caissons. The capping of the piles is herein interpreted as being that concrete, wood, or other material resting on the top of the piles where driven or placed and does not include any further form work above the capping. In many instances it has been found that the capping is called the girder. The above shall apply on such concrete or steel bridges constructed over land, highways, railroads, overpasses and include cloverleafs, interchanges, etc.
- (5) In the construction of concrete or steel bridges over water, the Pile Driver classification shall apply up to and including all of the form work to the top of the column, piers, or abutments supporting the steel and/or any other superstructures.
- (6) In the erection of false work, when necessary for the support of work under the Pile Driver classification, then such false work shall fall within their classification. False work necessary for the support of work under the Carpenter classification shall be done within such Carpenter classification, with the exception that where pile driving or power equipment is used for heavy timber false work, then such work shall come under the Pile Driver classification. This would include all rigging, signaling and tagging incidental to the placing of the heavy timber.
- (7) In the construction of open-cut sewers, the Pile Driver classification shall apply on all piling including wood, steel or concrete sheet piling, all bracing timber and form work incidental to the construction thereof.

Craft: PLASTERER (Union Rate)

Prevailing wage rates include the base rate as well as all applicable fringes

Plasterer-Journeyman.....	52.62
Plasterer-Foreman.....	55.93

ADD ZONE RATE

In addition to PLASTERER rates add the applicable amounts per hour, calculated from the South Virginia and Mill Street, Reno, Nevada:

Zone 1	0 to 70 miles	\$0.00
Zone 2	70 miles and over	\$8.00

ADD PREMIUM PAY

OVERTIME Eight (8) consecutive hours (exclusive of a meal period) shall constitute a day’s work at straight time. Five (5) consecutive days of eight (8) consecutive hours (exclusive of a meal period), Monday through Friday, shall constitute a week’s work. One and one half (1 ½) the regular straight time hourly rate shall be paid for all work over eight (8) hours. Sunday will be paid at double the regular straight time rate.

RECOGNIZED HOLIDAYS

All work performed on the following holidays shall be paid for at double the regular straight time rate: New Year’s Day, Memorial Day, Fourth of July, Labor Day, Admissions Day, Thanksgiving Day and the Friday after Thanksgiving and also Christmas Day.

If any of the above holidays fall on Sunday, the Monday following shall be considered a holiday.

No work shall be permitted on the Fourth of July or Labor Day, regardless of compensation or donation, except in case of emergency or to protect life and property. Permission to work shall be granted by the representative of the Union or its officer.

JOB DESCRIPTION: Excerpt from Agreement No NV. Plasterers Master Labor Agreement

This includes but is not limited to:

1. All building construction, including but not limited to the construction, erection, alteration, repair, modification, demolition, addition, or improvement in whole or in part of any building structures,
2. All interior or exterior plastering construction, restoration, repair and inspection of cement, stucco, stone imitation or any patent material when ornamental molded plaster, and the setting of same. All specialty finishes such as veneer, venetian, marmoreno and grasello. All custom and specialty finishes, including but not limited to custom rock, carved plaster, brick and block veneer, stone and wood. Smooth and finish surfaces of full system E.I.F.S. including sticking and shaping of foam pieces or surfaces by adhesive or mechanical installation. All spray or toweled on fireproofing, including cementitious and intumescent products. All plaster acoustical finish systems including, but not limited to, BASWA Phon and Fellert.
3. All work processes which represent technological change, replacement, modification or substitution for the work described above. In addition, all work and use of new materials or *2020-2024 Reno Plasterers Master Labor Agreement* 4 techniques involved in plaster construction including but not limited to what is known as green or sustainable construction technology.

Craft: PLUMBER/PIPEFITTER (Union Rate)

Prevailing wage rates include the base rate as well as all applicable fringes

Plumber/Pipefitter-Journeyman.....	71.10
Plumber/Pipefitter-Foreman.....	75.79
Plumber/Pipefitter-General Foreman.....	80.48

ADD ZONE RATE

In addition to PLUMBER/PIPEFITTER rates add the applicable amounts per statute air mile radius from the Nevada freeway interchange of Interstate 80 and 580.

Zone 1	0 to 75	\$0.00
Zone 2	Over 75 miles	\$8.00

A separate free zone will be established for employees permanently residing and working within a seventy-five (75) statute air mile radius of the Elko, Nevada Post Office.

Zone 1	0 to 75	\$0.00
Zone 2	Over 75 miles	\$8.00

ADD PREMIUM PAY

Premium pay for hours worked in excess of a shift of 8 hours or 12 hours or such other time increment set forth in the Collective Bargaining Agreement or on a weekend or holiday.

RECOGNIZED HOLIDAYS

New Year's Day, Memorial Day, Fourth of July, Labor Day, Nevada Admission Day, Thanksgiving Day, the Friday after Thanksgiving Day, Day Before Christmas and Christmas Day and any Friday preceding a Holiday falling on a Saturday, if worked, holidays shall be compensated at the double time rate.

JOB DESCRIPTION Excerpt from Agreement between LU 350 of United Assoc. of Journeymen and Apprentices of the Plumbing and Pipefitting Industry of United States and Canada

Installation of all heating and refrigeration systems and competent parts thereof, including fabrication, assembling, erection installation, dismantling, repairing, reconditioning, adjusting, altering servicing, handling, distributing, and tying on all piping materials appurtenances and equipment by method, including all hangars and supports of every description, all other work including the the trade relevant to oil burner and all other types of heating and refrigeration equipment including low voltage controls.

Craft: REFRIGERATION MECHANIC (Union Rate)

Prevailing wage rates include the base rate as well as all applicable fringes

Refrigeration-Journeyman.....	64.64
Refrigeration -Foreman.....	68.53
Refrigeration -General Foreman	72.41

ADD PREMIUM PAY

Premium pay for hours worked in excess of a shift of 8 hours or 12 hours or such other time increment set forth in the Collective Bargaining Agreement or on a weekend or holiday.

RECOGNIZED HOLIDAYS

New Year's Day, Memorial Day, Fourth of July, Labor Day, Nevada Admission Day, Thanksgiving Day, the Friday after Thanksgiving Day, Day Before Christmas and Christmas Day and any Friday preceding a Holiday falling on a Saturday, if worked, holidays shall be compensated at the double time rate.

JOB DESCRIPTION Excerpt from Agreement between LU 350 of United Assoc. of Journeymen and Apprentices of the Plumbing and Pipefitting Industry of United States and Canada

Installation of all heating and refrigeration systems and competent parts thereof, including fabrication, assembling, erection installation, dismantling, repairing, reconditioning, adjusting, altering servicing, handling, distributing, and tying on all piping materials appurtenances and equipment by method, including all hangars and supports of every description, all other work including the trade relevant to oil burner and all other types of heating and refrigeration equipment including low voltage controls.

Craft: ROOFER (Non-Union Rate)
(Does not include sheet metal roofs)

Prevailing wage rates include the base rate as well as all applicable fringes

Roofer-Journeyman.....33.64

JOB DESCRIPTION

Includes but is not limited to:

1. Installing and covering roofs and structures with slate, asphalt, wood and other related materials, other than sheet metal, by using brushes, knives, punches, hammers and other tools;
2. Spraying roofs, sidings and walls with material to bind, seal, insulate or soundproof sections of a structure;
3. Installation of all plastic, slate, slag, gravel, asphalt and composition roofing, and rock asphalt mastic when used for damp and waterproofing;
4. Installation of all damp resisting preparations when applied on roofs with mop, three-knot brush, roller, swab or spray system;
5. All types of preformed panels used in waterproofing;
6. Handling, hoisting and storing of all roofing, damp and waterproofing materials;
7. The tear-off and/or removal of roofing and roofing materials.

Craft: SHEET METAL WORKERS (Union Rate)

Prevailing wage rates include the base rate as well as all applicable fringes

Sheet Metal Worker Journeyman.....	73.87
Sheet Metal Worker Foreman.....	78.26
Sheet Metal Worker General Foreman.....	82.65

ADD ZONE RATE

In addition to SHEET METAL rates add the applicable amounts per hour, calculated based on a road from the courthouse in Reno, Nevada:

Zone 1	0 to 75 miles	\$0.00
Zone 2	75 to 100 miles	\$5.00
Zone 3	Over 100 miles	\$10.00 the employee shall be provided reasonable lodging and meal expenses.

ADD PREMIUM PAY

All hourly rates are subject to Over Time (One and one half 1 ½) of the Regular rate:

1. For all hours worked over Eight (8) Hours in one day or shift.
2. For the first Eight (8) Hours work on Saturday.

All hourly rates are subject to Double Time of the Regular Rate:

1. For all hours worked over Ten (10) Hours in one day or shift.
2. For all hours worked over Eight (8) Hours on Saturday.
3. For all hours worked on Sunday, New Year’s Day, President’s Day, Memorial Day, Independence Day, Labor Day, Nevada Day, Thanksgiving Day, Day after Thanksgiving, Day before Christmas, and Christmas Day.

RECOGNIZED HOLIDAYS

New Year’s Day, President’s Day, Memorial Day, Independence Day, Labor Day, Nevada Day, Thanksgiving Day, Day after Thanksgiving, Day before Christmas, and Christmas Day

JOB DESCRIPTION: Excerpt from Sheet Metal Local 26 Collective Bargaining Agreement

(a) manufacture, fabrication, assembling, handling, erection, installation, dismantling, conditioning, adjustment, alteration, repairing and servicing of all ferrous or nonferrous metal work and all other materials used in lieu thereof and of all HVAC systems, air veyor systems, exhaust systems, and air-handling systems regardless of material used including the setting of all equipment and all reinforcements in connection therewith; (b) all lagging over insulation and all duct lining; (c) testing and balancing of all air-handling equipment and duct work; (d) the preparation of all shop and field sketches whether manually drawn or computer assisted used in fabrication and erection, including those taken from original architectural and engineering drawings or sketches; (e) metal exterior wall systems, metal roofing; and (f) all other work included in the jurisdictional claims of International Association of Sheet Metal, Air, Rail and Transportation Workers.

Craft: SOILS and MATERIAL TESTER (Non-Union Rate)

Prevailing wage rates include the base rate as well as all applicable fringes

Soil Tester (Certified).....	46.81
Soils and Materials Tester.....	46.81

Craft: SPRINKLER FITTER (Union Rate)

Prevailing wage rates include the base rate as well as all applicable fringes

Sprinkler Fitter-Journeyman.....	65.31
Sprinkler Fitter Foreman.....	68.31
Sprinkler Fitter General Foreman.....	70.56

ADD ZONE RATE

In addition to SPRINKLER FITTER rates add the applicable amounts per hour, calculated based on a road from the courthouse in Reno, Nevada:

Zone 1	0 to 60 miles	\$0.00
Zone 2	60 to 80 miles	\$23.00
Zone 3	80 to 100 miles	\$33.00
Zone 4	Over 100 miles	\$125.00

JOB DESCRIPTION

Installing, dismantling, maintenance, repairs, adjustments and corrections of all fire protection and fire control systems including the unloading, handling by hand, power equipment and installation of all piping or tubing, appurtenances and equipment pertaining thereto, including both overhead and underground water mains, fire hydrants and hydrant mains, standpipes, and hose connections to sprinkler systems, sprinkler tank heaters, air lines and thermal systems used in connection with sprinkler and alarms systems, also all tanks and pumps connected thereto. Also including shall be CO2 and Cardox Systems, Dry Chemical Systems, Foam Systems and all other fire protection systems, but excluding steam fire protection systems.

Craft: SURVEYOR (Union Rate)

Prevailing wage rates include the base rate as well as all applicable fringes.

Rodman/Chainman	69.97
Instrumentman.....	71.43
Chief of Party Surveyor.....	72.69

ADD ZONE RATE

In addition to: **OPERATING ENGINEER, STEEL FABRICATOR & ERECTOR, and OPERATING ENGINEER PILEDRIVER**, rates add the applicable amounts per hour calculated based on a road mile from the Carson City Courthouse or Washoe County Courthouse

Zone 1	0 to 75 miles	\$0.00
Zone 2	75 to 150 miles	\$5.00
Zone 3	150 to 300 miles	\$6.00
Zone 4	300 miles over	\$7.00

ADD PREMIUM PAY

- One and one-half (1-1/2) times the applicable straight-time rate for the day, shift, work, equipment and classification shall be paid for all work (including repair work and field survey work) performed on Saturday and before a shift begins and after it ends, except when operating equipment servicing a craft that is receiving double time on commercial building construction, in which case double time shall be paid.
- Overtime. The following rates shall apply on Sundays and holidays and all work before a shift begins and after it ends:
 Saturday Shift Period. On any shift, Saturday shall be the twenty-four-hour period commencing at 12:00 midnight Friday.
 Sunday Shift Period. On any shift, Sunday shall be the twenty-four-hour period commencing at 12:00 midnight Saturday.
- For hours worked in excess of 12 on any such workday, an Employee shall be paid two (2) times the regular straight-time rate of pay for each hour so worked.

RECOGNIZED HOLIDAYS

Holidays. Double the applicable straight-time rate shall be paid for all work (including repair, maintenance and field survey work) performed on Sundays and the following holidays: New Year's Day (January 1); Memorial Day (last Monday in May); Independence Day (July 4); Labor Day (1st Monday in September); Nevada Admission Day (last Friday in October); Thanksgiving Day (4th Thursday in November); the day after Thanksgiving Day; and Christmas Day (December 25). Holidays falling on Sunday shall be observed on the following Monday. Holiday hours shall be reckoned on the same basis as Sunday hours.

JOB DESCRIPTION includes but is not limited to:

- Planning ground surveys designed to establish base lines, elevation and other geodetic measurements;
- Compiling data relevant to the shape, contour, gravitation, location, elevation and dimension of land and land features on or near the surface of the Earth for engineering, map making, mining, land evaluation, construction and other purposes;
- Surveying bodies of water to determine navigable channels and to secure data for construction of breakwaters, piers and other marine structures;
- Computing data necessary for driving and connecting underground passages, underground storage and volume of underground deposits.

Craft: TAPER (Union Rate)

Prevailing wage rates include the base rate as well as all applicable fringes

Taper-Journeyman.....	56.76
Taper-Foreman.....	60.83

ADD ZONE RATE

In addition to: TAPER rates add the applicable amounts per hour Zone Pay shall commence from the Washoe County Courthouse in Reno, Nevada, and shall be paid as follows:

Zone 1	0 to 40 miles	\$0.00
Zone 2	40 to 60 miles	\$2.50
Zone 3	over 60 miles	\$4.25

RECOGNIZED HOLIDAYS

New Year's Day, President's Day, Memorial Day, Independence Day, Labor Day, Veteran's Day, Thanksgiving Day, Day after Thanksgiving Day, Christmas Day. When holiday falls on a Sunday, the Monday following shall be observed as the holiday; holidays falling on Saturday shall be observed on the prior Friday.

ADD PREMIUM PAY

All overtime, except Sundays and holidays, will be time and one-half (1 1/2). Sundays and holidays will be paid double time (2X). Any and all work performed in excess of the regular workday of eight (8) hours, or ten (10) hours if mutually agreed to, and the regular workweek of forty (40) hours shall be considered overtime and shall be paid for at one and one-half (1 1/2) times the regular hourly rate.

JOB DESCRIPTION: Excerpt from Agreement between DC 16 and the independent Drywall Contractors of Northern Nevada

SECTION 1 -- The scope of work covered by this Agreement shall include (but not be limited to) all work operations, including distribution to the point of application, as follows:

- (a) Work or services pertaining to the preparation, spotting, pointing, detailing, flushing, sanding and finishing of interior and/or exterior gypsum, drywall, thin wall, concrete, steel, wood and plaster surfaces, spackling of all surfaces where adhesive materials are used; and all drywall pointing, taping and finishing.
- (b) Work or services pertaining to the application of all finish or flushing materials regardless of method of application or type of surface on which materials are applied, including but not limited to texture and simulated acoustic materials of all types and the application of radiant heat fill and steel fireproofing materials.
- (c) Work or services pertaining to the installation of protective coverings and masking prior to the application of finish materials.
- (d) The operation and care of all taping tools and texturing equipment used in the finishing and texturing of drywall and other surfaces including brushes, rollers, spray texturing equipment, miscellaneous hand, mechanical, and power tools, and the operation and maintenance of compressors required in the finishing and texturing of such surfaces.
- (e) No limitation shall be placed on the work covered by this Agreement by reason of the surface, type of material or purpose for which the materials used are designed or intended.
- (f) The cleanup of all materials and debris occasioned by any job operation at the site of construction, alteration, or repair undertaken whether such operation occurs on the interior or exterior of a building structure.

Craft: TILE SETTER/TERRAZZO WORKER/MARBLE MASON FINISHER (Union Rate)

Prevailing wage rates include the base rate as well as all applicable fringes

Tile Setter/Terrazzo Worker/Marble Mason - Finisher.....	40.32
Tile Setter/Terrazzo Worker/Marble Mason - Finisher Foreman.....	41.57
Tile Setter/Terrazzo Worker/Marble Mason Finisher- General Foremen.....	43.32

ADD PREMIUM PAY

All work in excess of forty (40) hours during the established work week shall be paid at the rate of one and one-half (1-1/2) times the hourly base wage rate in effect.

Employees shall be paid one and one-half (1-1/2) times the hourly wage rate for all hours worked over eight (8) in a single day and double time after ten (10) hours in a single day, Monday through Friday, except recognized holidays.

Daily Overtime Saturdays the first ten (10) hours performed on Saturday shall be paid at one and one-half (1-1/2) times the straight time wage rate.

Daily Overtime Sunday- Employees shall be paid double time on Sundays if forty (40) straight time hours have been worked during the proceeding work week.

Holidays shall be paid double time for hours owed on recognized holidays.

RECOGNIZED HOLIDAYS

New Year's Day, President's Day, Memorial Day, Independence Day, Labor Day, Veteran's Day, Thanksgiving Day, Day after Thanksgiving Day, Christmas Day. Any holiday falling on a Sunday will be observed on Monday.

JOB DESCRIPTION: Excerpt from Agreement between BAC 13 Nevada of the Mountain West Administrative District Council Master Labor Agreement

FINISHER'S WORK:

Finisher's work shall consist of assisting, helping or supporting the tile, marble and terrazzo mechanic by performing their historic and traditional work assignments. required to complete the proper installation of the work covered by Sections 5, 7 and 8 of this Code.

Craft: TILE SETTER/TERRAZZO WORKER/MARBLE MASON (Union Rate)

Prevailing wage rates include the base rate as well as all applicable fringes

Tile Setter - Journeyman.....	50.37
Tile Setter - Foreman.....	51.62
Tile Setter - General Foreman.....	53.37
Terrazzo/Marble Mason - Journeyman	51.87
Terrazzo/Marble Mason - Foreman	53.12
Terrazzo/Marble Mason - General Foreman.....	54.87

ADD ZONE RATE

In addition to TILE SETTER/TERRAZZO WORKER/MARBLE MASON rates add the applicable amounts per hour, calculated based on a road miles of over fifty (50) miles from the Washoe County Courthouse in Reno, Nevada:

Zone 1	0 to 50 miles	\$0.00
Zone 2	50 to 75 miles	\$3.75
Zone 3	Over 70 miles	\$8.13

ADD PREMIUM PAY

All work in excess of forty (40) hours during the established work week shall be paid at the rate of one and one-half (1-1/2) times the hourly base wage rate in effect.

Employees shall be paid one and one-half (1-1/2) times the hourly wage rate for all hours worked over eight (8) in a single day and double time after ten (10) hours in a single day, Monday through Friday, except recognized holidays.

Daily Overtime Saturdays the first ten (10) hours performed on Saturday shall be paid at one and one-half (1-1/2) times the straight time wage rate.

Daily Overtime Sunday- Employees shall be paid double time on Sundays if forty (40) straight time hours have been worked during the proceeding work week.

Holidays shall be paid double time for hours owed on recognized holidays.

RECOGNIZED HOLIDAYS

New Year's Day, President's Day, Memorial Day, Independence Day, Labor Day, Veteran's Day, Thanksgiving Day, Day after Thanksgiving Day, Christmas Day. Any holiday falling on a Sunday will be observed on Monday.

JOB DESCRIPTION: Excerpt from Agreement between BAC 13 Nevada of the Mountain West Administrative District Council Master Labor Agreement

TILE LAYERS' WORK:

Tile laying shall consist of, but not be limited to, the following work procedures and installation of the following materials:

A. The laying, cutting or setting of all tile where used for floors, walls, ceilings, walks, promenade roofs, stair treads, stair risers, facings, hearths, fireplaces, and decorative inserts, together with any marble plinths, thresholds or window stools used in connection with any tile work; also, preparing and setting all concrete, cement, brickwork, or other foundation or materials that may be required to properly set and complete such work; setting or bedding all tiling, stone, marble, composition, glass, mosaic, or other materials forming the facing, hearth or fireplace of a mantel, or the mantel complete, together with setting of all cement, brickwork, or other materials required in connection with the above work; also the slabbing and fabrication of tile mantels, counters and tile panels of every description, and the erection and installation of same; the building, shaping, forming, construction or repairing of all fireplace work, whether in connection with a mantel hearth facing or not, and the setting and preparing of all material, such as cement, plaster, mortar, brickwork, iron work or other materials necessary for the proper and safe construction and completion of such work, except that a mantel made exclusively of brick, marble or stone, shall be conceded to be bricklayers', marble setters' or stonemasons' work, respectively.

B. It will be understood that the word "tile" refers to all burned clay products, as used in the tile industry, either glazed or unglazed, and to all composition materials made in single units up to 15"x20"x2", except quarry tiles larger than 9"x9"x1 1/4", also to mixtures in tile form of cement, plastics and metals that are made for and intended for use as a finished floor surface, whether upon interior or exterior floors, stair treads, promenade roofs, garden walks, interior walls, ceilings, swimming pools, and all places where tile may be used to form a finished surface for practical use, sanitary finish or decorative purposes, for setting all accessories in connection therewith, or for decorative inserts in other materials.

C. All terra cotta called unit tile in sizes of 6"x12" or under, regardless of method of installation, quarry tile 9"x9"x1 1/4" or less; split brick or quarry tile or similar material where the bed is floated or screeded and the joints grouted. Where the work is installed by tile layers, the grouting and cleaning shall be supervised by the mechanic. The bedding, jointing, and pointing of the above materials shall be the work of the craft installing the same. All clay products known as terra cotta tile, unit tile, ceramic veneer and machine-made terra cotta, and like materials in sizes 6"x12" and less regardless of the method of installation. Where the preponderance of materials to be installed comes within the provisions of this Section and when there is also some material in excess of the sizes provided for in this Section, the tile setter shall install all such materials.

D. The preparation, setup, calibration, operation, cleaning, and routine maintenance of any mechanical devices or robotics used to install tile and related materials, or that otherwise assist the tile layer in performing any of the work described in Article II and Code 1 of the IU Constitution, as well as the preparation and ongoing maintenance of the work area to allow proper installation of tile and related materials.

Craft: TRAFFIC BARRIER ERECTOR (Union Rate)

Prevailing wage rates include the base rate as well as all applicable fringes

Traffic Barrier Erector.....48.53

ADD ZONE RATE

In addition to LABORER rates add the applicable amounts per hour, calculated based on a road miles from either the Carson City Courthouse or the Washoe County Courthouse:

Zone 1	0 to 75 miles	\$0.00
Zone 2	75 to 150 miles	\$5.00
Zone 3	150 to 300 miles	\$6.00
Zone 4	300 miles and over	\$7.00

ADD PREMIUM PAY

One and one half (1 ½) the regular straight time hourly rate shall be paid:

1. For all hours worked over eight (8) hours in one day or shift.
2. For any hours worked on Saturday from midnight to midnight.

Double the regular straight time hourly rate shall be paid for all time:

1. For all hours worked over twelve (12) hours in one day or shift.
2. For any hours worked on Sunday from midnight to midnight.
3. For any hours worked on holidays from midnight to midnight.

RECOGNIZED HOLIDAYS

If any of these holidays fall on Sunday, the Monday following shall be considered a Holiday.

New Year's Day, President's Day, Memorial Day, Independence Day, Labor Day, Veteran's Day, Thanksgiving Day, Day after Thanksgiving Day, Christmas Day.

JOB DESCRIPTION: Excerpt from Agreement between AGC and LIUNA Local 169

1. Distributing traffic control signs and markers along site in designated pattern;
2. Informing drivers of detour routes through construction sites;

Craft: Truck Driver (Non-Union Rate)

Prevailing wage rates include the base rate as well as all applicable fringes

Dump Trucks (Single or Multiple Units Including Semi's & Double Transfer Units), Dumpcretes and Bulk Cement Spreader

Under 4 yds. (water level).....	32.25
4 yds. & under 8 yds. (water level).....	32.25
8 yds. & under 18 yds. (water level).....	32.25
18 yds. & under 25 yds. (water level)	32.25
25 yds. & under 60 yds. (water level).....	32.25
60 yds. & under 75 yds. (water level)).....	32.25
75 yds. & under 100 yds. (water level)).....	32.25
100 yds. & under 150 yds. (water level)).....	32.25
150 yds. & under 250 yds. (water level)).....	32.25
250 yds. & under 350 yds. (water level)).....	32.25
350 yds. & over (water level).....	32.25

Transit Mix

Under 8 yds.....	32.25
Under 8 yds & including 12 yds.....	32.25
Over 12 yds.....	32.25

Transit Mix (Using Boom)

Transit mix with boom shall receive 16 cents per hour above the appropriate yardage classification rate of pay when such boom is used.....	32.25
--	-------

Water & Jetting Trucks

Up to 2,500 gallons.....	32.25
Up to 2,500 gallons & over.....	32.25
DW 20's & 21's & other similar Cat type, Terry Cobra LeTourneau pulls, Tournerocker, Euclid, & similar type equipment when pulling Aqua/Pak, Water Tank Trailers, & Fuel, and/or Grease Tank Trailer, or other miscellaneous Trailers, (except as defined under "Dump Trucks")	
Heavy Duty Transport (High Bed).....	32.25
Heavy Duty Transport(Gooseneck low bed).....	32.25
Tiltbed or Flatbed Pull Trailers..	32.25
Bootman, Comb. Bootman & Road Oiler.....	32.25
Flat Rack (2 or 3 axle unit).....	32.25

Bus & Manhaul Drivers

Up to 18,000 lbs. (single unit).....	32.25
18,000 lbs. and over	32.25
Warehousemen Spotter	32.25

Winch Truck & "A" Frame Drivers

Up to 18,000 lbs.....	32.25
18,000 lbs. and over.....	32.25
Warehousemen Spotter.....	32.25
Warehouse Clerk.....	32.25
Tire Repairmen.....	32.25
Truck Repairmen.....	32.25
Pick Up Truck & Pilot Cars (Jobsite)	32.25
Pick Up Truck & Pilot Cars (Over the road)	32.25
Truck Oil Greaser.....	32.25
Fuel Truck Driver.....	32.25
Fuel Man & Fuel Island Man.....	32.25
Oil Tanker.....	32.25

Oil Tanker with Pup.....	32.25
Foreman.....	32.25

TRUCK DRIVER

Includes but is not limited to:

Driving a tractor trailer combination or a truck to transport goods or materials at the site of a public work or between sites of a public work. (Also, see descriptions listed with Truck Driver rates, if any.)

Craft: WELL DRILLER (Non-Union Rate)

Prevailing wage rates include the base rate as well as all applicable fringes

Well Driller.....60.78

JOB DESCRIPTION

1. Setting, operating or tending to portable drilling rig machinery and related equipment to drill wells;
2. Extending stabilizing jackscrews to support and level a drilling rig;
3. Installing water well pumps;
4. Drillings wells for industrial water supplies, irrigation water supplies or water supplies for any other purpose; dewatering or other similar purposes; exploration; hole drilling for geologic and hydrologic information; and core drilling for geologic information.

GROUP CLASSIFICATIONS

LABORER, includes but is not limited to:

Group 1

- All cleanup work of debris, grounds, and building including windows and tile
- Dumpmen or Spotter (other than asphalt)
- Handling and Servicing of Flares, Watchmen
- General Laborer
- Guideposts and Highway Signs
- Guardrail Erection and Dismantling
- Limber, Brushloader and Piler
- Pavement Marking and Highway Striping
- Traffic Barrier Erector
- Tending to portable space heaters
- Profilograph work all types manual, self propelled or carts
- Gabion basket, building, handling, installation and rigging
- Dry set paver work
- Traffic Barrier Erector

Group 2

- Choker setter or Rigger (clearing work only) Pittsburgh
- Chipper and similar type brush shredders
- Concrete worker (wet or dry) all concrete work not listed in Group 3 included but not limited to: concrete forms stripping, handling, cleaning, oiling and moving to the next point of installation.
- Crusher or Grizzly Tender
- Greasing Dowels
- Guinea Chaser (Stakemen)
- Panel Forms (wood or metal) handling, cleaning and stripping of Loading and unloading, (Carrying and handling of all rods and material for use in reinforcing concrete
- Railroad Trackmen (maintenance, repair or builders)
- Sloper
- Semi-Skilled Wrecker (salvaging of building materials other than those listed in Group 3)
- Waterproofing work
- Epoxy rebar/dowels and anchoring dowel baskets
- Placement pouring of concrete including any epoxy resin or similar materials, rodding, spreading and tamping concrete, brooming or brushing, hand application of curing compounds, applying topping (wet or dry) colors or grits, and exposed finishes for architectural work
- Concrete patching, dry packing, chipping, stoning, and grouting
- Concrete cold weather/rain protection and curing
- Placement /anchoring of all earth stabilization/filters fabrics,
- Mechanically stabilized Earth (MSE) and Keystone type retaining walls rigging, placing , aligning, backfilling and installation of dead men and any stabilization components

Group 3

- Asphalt Workers (Ironers, Shovelers, Cutting Machine)
- Buggymobile
- Chainsaw, Faller, Logloader and Bucker

- Compactor (all types)
- Concrete Mixer under 1/2 yard
- Concrete Pan Work (Breadpan type), handling, cleaning\stripping
- Concrete Saw, Chipping, Grinding, Sanding, Vibrator
- Cribbing, Shoring, Lagging, Trench Jacking, Hand-Guided Lagging Hammer
- Curbing or Divider machine
- Curb Setter (precast or cut)
- Ditching Machine (hand-guided)
- Drillers Helper, Chuck Tender
- Fence erector including safety, chain link, turtle, field and barbe wire fencing
- Form Raiser, Slip Forms
- Grouting of Concrete Walls, Windows and Door Jams
- Headerboardmen
- Jackhammer, Pavement Breaker, Air Spade
- Mastic Worker (wet or dry)
- Pipewrapper, Kettlemen, Potmen, and men applying asphalt, creosote and similar type materials
- All Power Tools (air, gas, or electric), Post Driver
- Riprap-Stonepaver and RockSlinger, including placing of sack concrete wet or dry
Rototiller
- Rigging and Signaling in connection with Laborers' work
- Sandblaster, Potmen, Gunmen or Nozzlemen water blasting not covered in group 5A
- Vibra-screed
- All demolition and wrecking work including but not limited t any torch work cutting, burning, plasma are, dust control, and salvaging (removing and salvaging of all materials, windows, doors, plumbing, and electrical fixtures) and use of customary tools and equipment for demolition and wrecking
- All underpinning foundation work, digging and underpinning pits, removal of debris with tuggers or other methods, cutting, handling and installing all shoring boards and lagging boards used for underpinning and foundation work, placement and tying of steel reinforcing for underpinning piers, all tiebacks and soil nail work drilling and grouting, all soldier beam work and us of customary tools and equipment for underpinning foundation work

Group 3A

- Concrete Specialist
- Setting screeds
- Screed pins
- Curb forms and curb and gutter forms,
- Using Darby and push floats,
- Hand trowels or hand floating
- Marking edging
- Using base cove or step tools
- Spreading and finishing gypsum
- Concrete grinding machines (the terms does not include Rotomill machines for highway overlay grinding)
- Troweling machines,
- Floating machines
- Finishing of epoxy or resin materials,
- Operation of skill saw
- Laser Screed
- Laser Level

- Curb and Slipform machines,
- Stamps or other means or texturing,
- Any new devices which are beneficial to the construction of or with concrete or related products.

Group 4

- Burning and Welding in connection with Laborers' work
- Joy Drill Model TWM-2A, Gardner Denver Model DN143 and similar type drills (in accordance with Memorandum of Understanding between Laborers and Operating Engineers dated at Miami, Florida, Feb. 3, 1954) and Track Drillers, Diamond Core Drillers, Wagon Drillers, Mechanical Drillers on Multiple Units
- High scalers including but not limited to laying, anchoring, pinning, cabling and stretching of any rock fall netting, mesh or wire fabric and use of customary tools and equipment for high scaling
- Concrete pump operator
- Heavy Duty Vibrator with Stinger 5" diameter or over
- Pipelayer, Caulker and Bander
- Pipelayer-waterline, Sewerline, Gasoline, Conduit and all other types of composition for any purpose buried under ground outside of building including, stringing, trench shoring, backfilling sanding, caution taping, all walk behind equipment and spotting
- Laborer work in connection with micro tunneling, directional drilling and pipe-jacking
- Cathodic protection, grounding for pipe work
- Cleaning of Utility Lines
- Slip Lining of Utility Lines (including operation of Equipment)
- TV Monitoring and Grouting of Utility Lines
- Asphalt Rakers and Asphalt dump Man
- All mechanical and pressurized pipe work, including the installation of pipe above and below ground, cathodic protection, bolt up, and support installation in connection to water conveyance, c

Group 4A

- Foreman

Group 5

- Construction Specialists
- Blasters and Powdermen, all work of loading, placing, and blasting of all powder and explosives of any type, regardless of method used for such loading and placing
- Asbestos removal
- Lead abatement
- Hazardous waste
- Material removal

Group 5A

- Pavement Marking and Highway Striping
- Pavement Marking and Highway Striping Foreman
- Pavement Marking and Highway Striping work includes but is not limited to: All work by any method performed in connection with the permanent or temporary application and installation of pavement marking of any kind, brand, type or style on parking lots, airfields, highways, streets and other such surfaces and all work performed in connection with removal of pavement.

Group 6

- Guniting Foremen, Nozzlemen, Rodmen, Gunmen, Materialmen, Reboundmen

- Tunnel and shaft workers/miners and use of customary tools and equipment for tunnel and mine work All worked performed in a compressed air tunnel shaft or chamber including the use of hand, power tools or equipment as necessary in connection with compressed air work
-

OPERATING ENGINEER, includes but is not limited to:

Group 1

- Engineer Assistant

Group 1A

- Oiler (Construction)
- Partsman

Group 2

- Compressor Operator
- Material Loader and/or Conveyor Operator (handling building materials)
- Pump Operator

Group 3

- Bobcat or similar loader, 1/4 cu. yd. or less
- Concrete Curing Machines (streets, highways, airports, canals)
- Conveyor Belt Operator (tunnel)
- Forklift (under 20)
- Engineer Generating Plant (500 K.W.)
- Mixer Box Operator (concrete plant)
- Motorman
- Rodman/Chainman
- Rotomist Operator
- Oiler (truck crane)

Group 4

- Concrete Mixer Operator, Skip type
- Dinky Operator
- Forklift (20' or over) or Lumber Stacker
- Ross Carrier
- Skip Loader Operator (under one (1) cu. yd.)
- Tie Spacer

Group 5

- Concrete Mixers (over one (1) cu. yd.)
- Concrete Pumps or Pumpcrete Guns
- Elevator and Material Hoist (one (1) drum)
- Groundman for Asphalt Milling and similar

Group 6

- Auger type drilling equipment up to and including 30 ft. depth digging capacity M.R.C.
- Boom Truck or Dual-Purpose a-Frame Truck
- B.L.H. Lima Road Pactor or similar
- Chip Box Spreader (Flaherty type or similar)
- Concrete Batch Plant (wet or dry)
- Concrete Saws (highways, streets, airports, canals)
- Locomotives (over thirty (30) tons)
- Maginnis International Full Slab Vibrator (airports, highways, canals and warehouses)
- Mechanical Finishers (concrete) (Clary, Johnson, Bidwell Bridge Deck or similar types)

- Mechanical Burn, Curb and/or Curb and Gutter Machine (concrete or asphalt)
- Pavement Breaker, Truck Mounted, with compressor combination
- Pavement Breaker or Tamper (with or without compressor combination)
- Power Jumbo Operator (setting slip-forms, etc., in tunnels)
- Roller Operator (except asphalt)
- Self-Propelled Tape Machine
- Self-Propelled Compactor (single engine)
- Self-Propelled Power Sweeper Operator
- Slip-Form Pump (power-driven by hydraulic, electric, air, gas, etc. lifting device for concrete forms)
- Small Rubber-Tired Tractors
- Snooper Crane, Paxton-Mitchell or similar
- Stationary Pipe Wrapping, Cleaning and Bending Machine Operator

Group 7

- Auger type drilling equipment over 30 ft. depth digging capacity M.R.C.
- Compressor (over 2)
- Concrete Conveyor or Concrete Pump, truck or equipment mounted (any assistance required shall be performed by an Assistant to Engineer) Boom length to apply Concrete Conveyor, Building Site
- Drilling and Boring Machine, vertical and horizontal (not to apply to waterliners, wagon drills or jack hammers)
- Crusher Plant Engineer
- Generators
- Instrument Man
- Kolman Loader
- Material Hoist (two (2) or more drums)
- Mine or Shaft Hoist
- Pipe Bending Machines (pipeline only)
- Pipe Cleaning Machines (tractor-propelled and supported)
- Pipe Wrapping Machines (tractor-propelled and supported)
- Portable Crushing and Screening Plants
- Post Driller And/or Driver
- Pumps (over 2)
- Screedman (except asphaltic or concrete paving)
- Self-Propelled Boom-Type Lifting Device (center mount) (on ten (10) ton capacity or less)
- Slusher Operator
- Soil Tester (Certified)
- Soils and Materials Tester
- Surface Heater and Planer Operator
- Trenching Machine (maximum digging capacity three (3) ft. depth) (Any assistance in the operation, if needed, shall be performed by an Assistant to Engineer)
- Truck-Type Loader
- Welding Machines (gasoline or diesel)

Group 8

- Articulated on-Site Dump Trucks
- Asphalt Plant Engineer
- Asphalt Milling Machine

- Cast-In-Place Pipe-Laying Machine
- Combination Slusher and Motor Operator
- Concrete Batch Plant (multiple units)
- Dozer Operator
- Drill Doctor
- Elevating Grader Operator
- Stiff Frame Off Road Haul Trucks
- Grooving and Grinding Machine (highways)
- Ken Seal Operator
- Marination Plant
- Loader (up to and including two and one-half (2 1/2) cu. yds)
- Mechanical Finishers or Spreader Machine (asphalt, Barber-Greene or similar)
- Shuttle Buggy
- Mechanical Trench Shield
- Mixermobile
- Push Cats
- Road Oil Mixing Machine Operator Wood-Mixer (and other similar Pugmill equipment)
- Roller Operator (asphalt)
- Rubber-Tired Earthmoving Equipment (up to and including thirty-five (35) cu. yds. "struck " M.R.C., Euclids, T-Pulls, DW10, 20, 21 and similar)
- Water Pull
- Screedman (Barber-Greene and similar) (asphaltic or concrete paving)
- Self-Propelled Compactors with Dozer; Hyster 450, Cat 825 or similar
- Sheepfoot
- Small Tractor (with boom)
- Soil Stabilizer (P & H or equal)
- Timber Skidder (rubber-tired) or similar equipment
- Track Loader
- Tractor-Drawn Scraper
- Tractor Operator
- Tractor-Mounted Compressor Drill Combination
- Trenching Machine Operator (over three (3) feet depth)
- Tri-Batch Paver
- Tunnel Badger or Tunnel Boring Machine Operator
- Tunnel Mole Boring Machine
- Vermeer T-600b Rock Cutter
- Vacuum Truck(excludes trailer mounted vaccums)

Group 9

- Chicago Boom
- Combination Backhoe and Loader (up to and including 3/8 cu. yd.)
- Combination Mixer and Compressor (gunite)
- Heavy Duty Repairman and/or Welder
- Lull Hi-Lift (twenty (20) feet or over)
- Mucking Machine
- Sub-Grader (Gurries or other types)
- Tractor (with Boom) (D6 or larger)
- Track-Laying-Type Earthmoving Machine (single engine with tandem scrapers)

Group 10

- Boom-Type Backfilling Machine
- Bridge Crane
- Cary-Lift or similar
- Chemical Grouting Machine
- Chief of Party
- Derricks (two (2) Group 10 Operators required when swing engine remote from hoist)
- Derrick Barges (except excavation work)
- Euclid Loader and similar types
- Heavy Duty Repairman
- Heavy Duty Rotary Drill Rigs
- Lift-Slab (Vagtborg and similar types)
- Loader (over two and one-half (2 1/2 cu. yds. up to and including four (4) cu. yds.)
- Locomotive (over one hundred (100) tons, single or multiple units)
- Multiple-Engine Earthmoving Machines (Euclid Dozers, etc.)
- Pre-Stress Wire Wrapping Machine
- Rubber-Tired Scraper, Self-Loading
- Single-Engine Scraper (over thirty-five (35) cu. yds.)
- Shuttle Car (Reclaim Station)
- Train Loading Station
- Trenching Machine multi-engine with sloping attachments (Jefco or similar)
- Vacuum Cooling Plant
- Whirley Crane (up to and including twenty-five (25) tons)

Group 10A

- Backhoe-Hydraulic (up to and including one (1) cu. yd.)
- Backhoe (up to and including one (1) cu. yd.) (Cable)
- CMI Dual Lane Auto-Grader SP30 or similar type
- Cranes (not over twenty-five (25) tons) (hammerhead and gantry)
- Finish Blade
- Gradalls (up to and including one (1) cu. yd.)
- Motor Patrol Operator
- Power Shovels, Clamshells, Draglines, Cranes (up to and including one (1) cu. yd.)
- Rubber-Tired Scraper, Self-Loading (twin engine)
- Self-Propelled Boom-Type Lifting Device, center mount (over 10 tons up to and including 25 tons)

Group 11

- Automatic Asphalt or Concrete Slip-Form Paver
- Automatic Railroad Car Dumper
- Canal Trimmer
- Cary Lift, Campbell or similar type
- Cranes (over twenty-five (25) tons)
- Euclid Loader when controlled from the Pullcat
- Finish Blade
- Gradesetter, Grade Checker
- Highline Cableway Operator
- Loader (over four (4) cu. yds. up to and including twelve (12) cu. yds.)
- Multi-Engine Earthmoving Equipment (up to and including seventy-five (75) cu. yds. struck m.r.c.)
- Multi-Engine Scrapers (when used to Push Pull)

- Power Shovels, Clamshells, Draglines, Backhoes Gradalls (over one (1) cu. yd. and up to and including seven (7) cu. yds. m.r.c.)
- Self-Propelled Boom-Type Lifting Device (center mount) (over 25 tons m.r.c.)
- Self-Propelled Compactor (with multiple-propulsion power units)
- Single-Engine Rubber-Tired Earthmoving Machine, with Tandem Scraper
- Slip-Form Paver (concrete or asphalt)
- Tandem Cats and Scraper
- Tower Crane Mobile (including Rail Mount)
- Truck Mounted Hydraulic Crane when remote control equipped (over 10 tons up to and including 25 tons)
- Universal Liebherr and Tower Cranes (and similar types)
- Wheel Excavator (up to and including seven hundred fifty (750) cu. yds. per hour)
- Whirley Cranes (over twenty-five (25) tons)

Group 11A

- Band Wagons (in conjunction with Wheel Excavators)
- Operator of Helicopter (when used in construction work)
- Loader (over twelve (12) cu. yds.)
- Multi-Engine Earthmoving Equipment (over seventy-five (75) cu. yds. "struck" m.r.c.)
- Power Shovels, Clamshells, Draglines, Backhoes, and Gradalls (over seven (7) cu. yds. m.r.c.)
- Remote-Controlled Earth Moving Equipment
- Wheel Excavator (over seven hundred fifty (750) cu. yds. per hour)

Group 11B

- Holland Loader or similar or Loader (over 18 cu. yds.)
-

OPERATING ENGINEERS - Steel Fabricator & Erector

Group 1

- Cranes over 100 tons
- Derrick over 100 tons
- Self-Propelled Boom Type Lifting Devices over 100 tons

Group 2

- Cranes over 45 tons up to and including 100 tons
- Derrick, 100 tons and under
- Self-Propelled Boom Type Lifting Device, over 45 tons
- Tower Crane

Group 3

- Cranes, 45 tons and under
- Self-Propelled Boom Type Lifting Device, 45 tons and under

Group 4

- Chicago Boom
- Forklift, 10 tons and over
- 59
- Heavy Duty Repairman/Welder

Group 5

- Boom Cat
-

OPERATING ENGINEER -PILEDRIVER

Group 1

- Derrick Barge Pedestal mounted over 100 tons
- Clamshells over 7 cu. yds.
- Self-Propelled Boom Type Lifting Device, over 100 tons
- Truck Crane or Crawler, land or barge mounted over 100 tons

Group 2

- Derrick Barge Pedestal mounted 45 tons up to and including 100 tons
- Clamshells up to and including 7 cu. yds.
- Self-Propelled Boom Type Lifting Device over 45 tons
- Truck Crane or Crawler, land or barge mounted, over 45 tons up to and including 100 tons

Group 3

- Derrick Barge Pedestal mounted under 45 tons
- Self-Propelled Boom Type Lifting Device 45 tons and under
- Skid/Scow Piledriver, any tonnage
- Truck Crane or Crawler, land or barge mounted 45 tons and under

Group 4

- Assistant Operator in lieu of Assistant to Engineer
- Forklift, 10 tons and over
- Heavy Duty Repairman/Welder

Group 5

No current classification

Group 6

- Deck Engineer

Group 7

No current classification

Group 8

- Deckhand
 - Fireman
-

Forms

(to be used following award of bid)

- 1) Contract Form**
- 2) Performance Bond**
- 3) Payment Bond**



TITLE
BID # BIDNUMBER
PWP# PWPNUMBER

THIS CONTRACT made and entered into on this **DAY day of MONTH, YEAR** by and between the City of Sparks, Nevada, a municipal corporation, existing under and by virtue of the laws of the State of Nevada, hereinafter called "City", and **CONTRACTORNAME**, a qualified Contractor in the class of work required, hereinafter called "Contractor".

W I T N E S E T H

WHEREAS, the City has awarded a contract to Contractor for providing material and/or performing the work hereinafter mentioned in accordance with the proposal of said Contractor;

WHEREAS, the Contractor will provide the material and/or perform the work for the compensation stated in said proposal, an amount which has been arrived at between the parties;

WHEREAS, each party is willing to and does assume joint liability for the contents of this Contract, and each party accordingly agrees that it shall not be construed against any party as a drafting party;

NOW, THEREFORE, IT IS AGREED as follows:

1. Scope of Work:

The scope of work for this contract is generally defined as **TITLE**. The City's Contract Documents and Contractor's Entire Proposal are on file with the City of Sparks. All terms, conditions and requirements contained within these Documents, including any and all bid documents, addenda and specifications issued by the City, are hereby incorporated by reference into this Contract.

The Contractor shall perform within the time stipulated, the Contract as herein defined and shall provide and furnish any and all of the labor, materials, methods or processes, equipment implements, tools, machinery and equipment, and all utility, transportation and other services required to construct, install and put in complete order for use in a good and workmanlike manner all of the work covered by the Contract in connection with strict accordance with the plans and specifications therein, which were approved by said City and are on file with the City, including any and all addenda issued by the City, and with the other contract documents hereinafter enumerated.

2. Payment for Project Services

As full consideration for the Services to be performed by Contractor, City agrees to pay Contractor as set forth in accordance with the bid and not to exceed fee of **\$AMOUNT** for the project.

A monthly progress payment in the amount of ninety-five percent (95%) of the value of the work completed may be made every thirty (30) days upon application by the Contractor and certification by the Project Manager that such work has been completed.

Partial payments will be made once each month as the work satisfactorily progresses and after acceptance



by the authorized City representative. The progress estimates shall be based upon materials in place, or on the job site and invoiced, and labor expended thereon. From the total of the amount ascertained will be deducted an amount equivalent to five percent (5%) of the whole, which five percent (5%) will be retained by the City until after completion of the entire Contract in an acceptable manner. Any time after fifty percent (50%) of the value of the work has been completed, the City will make any of the remaining partial payments in full.

No such estimates or payments shall be required to be made, when, in the judgment of the City Project Manager, the work is not proceeding in accordance with the provision of the Contract, or when in his judgment the total value of the work done since last estimate amounts to less than Five Hundred Dollars (\$500.00).

The cost of materials conforming to the plans and specifications (materials being those which are required to be contained and incorporated in a finished contract bid item) delivered to the project and not at the time incorporated in the work, may also be included in the estimate for payment. No such estimate or payment shall be construed to be an acceptance of any defective work or improper material. The Contractor shall be responsible for, and shall not remove from the project any material that has been included in the estimate for payment.

Final payment shall be made upon the Project Manager certifying that the Contractor has satisfactorily completed the work in conformity with the Contract Documents.

3. Time for Completion:

The Contractor shall deliver the material and/or services called for in the specifications/proposal and within the delivery time specified and in accordance with the terms of the contract. Work shall be completed within [REDACTED] days from the Notice to Proceed issued by the City of Sparks Purchasing Division. The Contractor shall not alter or vary any terms or conditions contained or incorporated herein, including but not limited to, the quantity, price, delivery date or date designated as After Receipt of Order (ARO) or date for commencement or completion of services as mutually agreed upon, unless such alteration or variation is consented to in writing by a duly authorized representative of the City.

The City reserves the right to cancel resultant Contract upon ten days written notice in the event the type and quality of the product or work performance is unsatisfactory or in default, subject to Contractor's right to cure as outlined in termination clause.

This is a non-exclusive Contract and the City reserves the right to acquire the material and/or services at its discretion, from other sources during the term of this Contract.

4. No Unlawful Discrimination:

In connection with the performance of work under this contract, the contractor agrees not to discriminate against any employee or applicant for employment because of race, creed, color, national origin, sex, sexual orientation, gender identity or expression, or age, including, without limitation, with regard to employment, upgrading, demotion or transfer, recruitment or recruitment advertising, layoff or termination, rates of pay or other forms of compensation, and selection for training, including, without



limitation, apprenticeship. The contractor further agrees to insert this provision in all subcontracts hereunder, except subcontracts for standard commercial supplies or raw materials.

Any violation of these provisions by Contractor shall constitute a material breach of contract. In all cases where persons are employed in the construction of public works, preference must be given when the qualifications of the applicants are equal:

- A) First: To honorably discharged soldiers, sailors and marines of the United States who are citizens of the State of Nevada.
- B) Second: To other citizens of the State of Nevada

If the provisions of this section are not complied with by the contractor engaged on the public work, the contract is void, and any failure or refusal to comply with any of the provisions of this section renders any such contract void and subject to the exceptions contained in this section, no money may be paid out of the State Treasury or out of the treasury of any political subdivision of the State to any person employed on any work mentioned in this section unless there has been compliance with the provisions of this section. Any contractor engaged on a public work or any other person who violates any of the provisions of this section is guilty of a misdemeanor. The penalties provided for in this section do not apply where violations thereof are due to misrepresentations made by the employee or employees.

5. No Illegal Harassment:

Violation of the City's harassment policy, which is incorporated by reference and available from the Human Resource Division, by the Contractor, its officers, employees, agents, vendors, consultants, subcontractors and anyone from whom it is legally liable, while performing or failing to perform Contractor's duties under this Contract shall be considered a material breach of contract.

6. Lawful Performance:

Vendor shall abide by all Federal, State and Local Laws, Ordinances, Regulations, and Statutes as may be related to the performance of duties under this agreement. In addition, all applicable permits and licenses required shall be obtained by the vendor, at vendor's sole expense.

7. Preferences (This Section IS IS NOT Applicable to this contract):

To the extent Contractor has sought and qualified for a bidding preference and this project has a value of over \$250,000 pursuant to Nevada Revised Statutes Chapter 338, Contractor acknowledges and agrees that the following requirements will be adhered to, documented and attained for the duration of the Project:

- 1. At least 50 percent of the workers employed on the Project (including subcontractors) hold a valid driver's license or identification card issued by the Nevada Department of Motor Vehicles;
- 2. All vehicles used primarily for the public work will be (a) registered and (where applicable) partially apportioned to Nevada; or (b) registered in Nevada; and
- 3. The Contractor shall maintain and make available for inspection within Nevada all payroll records related to the Project.

Contractor recognizes and accepts that failure to comply with any requirements herein shall be a



material breach of the contract and entitle the City of Sparks to liquidated damages in the amount set by statute. In addition, the Contractor recognizes and accepts that failure to comply with any requirements herein may lose its certification for a preference in bidding and/or its ability to bid on any contracts for public works pursuant to NRS Chapter 338.

To the extent Contractor has sought and qualified for a bidding preference and this project has a value of over \$250,000 pursuant to Nevada Revised Statutes Chapter 338, each contract between the contractor, applicant or design-build team and a subcontractor must provide for the apportionment of liquidated damages assessed pursuant to this section if a person other than the Contractor was responsible for the breach of a contract for a public work caused by a failure to comply with a requirement of Items 1-5 within this section. The apportionment of liquidated damages must be in proportion to the responsibility of each party for the breach.

8. Prevailing Wages:

The Contractor and subcontractors shall be bound by and comply with all federal, state and local laws with regard to minimum wages, overtime work, hiring and discrimination, including Chapter 338 of the NRS, which is entitled, "Public Works Projects."

The Contractor shall ensure that all employees on the work site are paid in accordance with the CURRENT PREVAILING WAGE RATES AS APPROVED BY THE STATE LABOR COMMISSIONER, whenever the actual value of the Contract totals One Hundred Thousand Dollars (\$100,000) or more, or when required by the Supplementary Conditions. If a Change Order causes a Contract to exceed One Hundred Thousand Dollars (\$100,000), the State Labor Commissioner may audit the entire Contract period.

Questions involving the Prevailing Wage Rates for the City of Sparks should be referred to the Labor Commissioner, State of Nevada, at (775) 687-4850.

When federal money is associated with the project making the Contract subject to both state and federal wage rates, the Contractor shall not pay less than the higher rate when the two rates differ for similar kinds of labor.

- A. Posting of Minimum Wage Rates - In accordance with NRS, Chapter 338, Section 338.020, the Contractor shall post the hourly and daily rate of wages to be paid to each of the classes of mechanics and workers on the site of Work of this Contract in a place generally visible to the workers.
- B. Pursuant to NRS 338.060 and 338.070, the Contractor hereby agrees to forfeit, as a penalty to the City of Sparks, not less than Twenty Dollars (\$20) nor more than Fifty Dollars (\$50) for each calendar day or portion thereof that each worker employed on the Contract is paid less than the designated rate for any work done under the Contract, by the Contractor or any subcontractor under him, or is not reported to the City of Sparks as required by NRS 338.070.
- C. The contractor and each subcontractor shall keep or cause to be kept an accurate record showing, for each worker employed by the contractor or subcontractor:
 - (1) The name of the worker;



-
- (2) The occupation of the worker;
 - (3) If the worker has a driver's license or identification card, an indication of the state or other jurisdiction that issued the license or card; and
 - (4) The actual per diem, wages and benefits paid to the worker.

In addition, the contractor and each subcontractor shall keep or cause to be kept an accurate record showing, for each worker employed by the contractor or subcontractor who has a driver's license or identification card:

- (1) The name of the worker;
- (2) The driver's license number or identification card number of the worker; and
- (3) The state or other jurisdiction that issued the license or card.

D. The records in Section C above must be open at all reasonable hours to the inspection of the City of Sparks, and its officers and agents. A copy of the each record for each calendar Month for the General Contractor and all Sub-Contractors must be submitted to the City of Sparks no later than 15 days after the end of each month for the previous months' wages.

9. Apprenticeship Utilization Act:

Bidder acknowledges that the Nevada Legislature has enacted state laws requiring contractors engaged in vertical or horizontal construction who employ workers on one or more public works during a calendar year to use varying levels of apprentices on such public works. *See* NRS 338.01165; SB 82 (2023). Contractor acknowledges that Senate Bill 82 (2023) places compliance and reporting requirements on contractors and subcontractors engaged in public works project, and requires contractors and subcontractors engaged in public works projects to meet annual apprentice use thresholds set by state law, including obligations to provide the Nevada Labor Commissioner with supporting documentation when requested, and an obligation to provide an annual report to the Nevada Labor Commissioner documenting its compliance with Nevada apprenticeship requirements. Contractor acknowledges and certifies that it will comply with NRS 338.01165 and SB 82 (2023), as each may be amended in the future.

10. Acceptance by the City:

It is expressly understood and agreed that all materials provided and/or work done by the Contractor shall be subject to inspection and acceptance by the City at its discretion, and that any progress inspections and approval by the City of any item or work shall not forfeit the right of the City to require the correction of faulty workmanship or material at any time during the course of the work, although previously approved by oversight. Nothing herein contained shall relieve the Contractor of the responsibility for proper construction and maintenance of the work, materials and equipment required under the terms of this Contract until all work has been completed and accepted by the City.

11. Waiver:

No waiver of any term, provision or condition of this Contract, whether by conduct or otherwise, in any one or more instances, shall be deemed to be nor shall it be construed as a further or continuing waiver of any such term, provision or condition of this Contract. No waiver shall be effective unless it is in writing and signed by the party making it.

12. Notices:



All notices required to be given in writing by this Contract shall be deemed to be received (i) upon delivery if personally delivered, or (ii) when receipt is signed for if mailed by certified or registered mail, postage prepaid, or by express delivery service or courier, when addressed as follows (or sent to such other address as a Party may specify in a notice to the others):

PURCHASING MANAGER
CITY OF SPARKS
431 PRATER WAY
PO BOX 857
SPARKS, NV 89432-0857

CONTRACTOR:
CONTACT
CONTRACTORNAME
ADDRESS
CITY, STATE ZIP
e-mail:

13. Arbitration:

Any and all disputes, controversies or claims arising under or in connection with this Contract, including without limitation, fraud in the inducement of this Contract, or the general validity or enforceability of this Contract, shall be governed by the laws of the State of Nevada without giving effect to conflicts of law principles, may be submitted to binding arbitration before one arbitrator, and shall be conducted in accordance with the Commercial Arbitration Rules of the American Arbitration Association in a private manner in Washoe County, Nevada. This award shall be final and judgment may be entered upon it in any court having jurisdiction thereof. In reaching this final award, the arbitrator shall have no authority to change or modify any provision of this Contract. All other expenses of arbitration shall be borne equally by the parties. All fees, including legal fees, shall be borne by the party who incurred them. All costs of enforcement shall be borne by the losing party. Each party shall have the right to discovery in accordance with the Nevada Rules of Civil Procedure.

14. Jurisdiction and Venue:

In the event the arbitration award is challenged, any action or proceeding seeking to do so must be brought in the courts of the State of Nevada, County of Washoe, or if the party can acquire subject-matter jurisdiction, in the United States District Court for the District of Nevada in the City of Reno. Each of the parties consents to the personal jurisdiction of such courts (and of the appropriate appellate courts) in any such action or proceeding and waives any objection to venue laid therein. Process in any action or proceeding referred to in the preceding sentence may be served on either party by sending it certified mail to the respective addresses designated for notice.

15. Indemnification:

To the fullest extent permitted by law, upon award, Contractor shall hold harmless, indemnify, defend and protect City, its affiliates, officers, agents, employees, volunteers, successors and assigns (“Indemnified Parties”), and each of them from and against any and all claims, demands, causes of action, damages, costs, expenses, actual attorney’s fees, losses or liabilities, in law or in equity, of every kind and nature whatsoever (“Claims”) arising out of or related to any act or omission of Contractor, its employees, agents, representatives, or Subcontractors in any way related to the performance of work under this Agreement by Contractor, or to work performed by others under the direction or supervision of Contractor, including but not limited to:



1. Personal injury, including but not limited to bodily injury, emotional injury, sickness or disease, or death to persons;
2. Damage to property of anyone, including loss of use thereof;
3. Penalties from violation of any law or regulation caused by Contractor's action or inaction;
4. Failure of Contractor to comply with the Insurance requirements established under this Agreement;
5. Any violation by Contractor of any law or regulation in any way related to the occupational safety and health of employees.

In determining the nature of the claim against City, the incident underlying the claim shall determine the nature of the claim, notwithstanding the form of the allegations against City.

If City's personnel are involved in defending such actions, Contractor shall reimburse City for the time and costs spent by such personnel at the rate charged City for such services by private professionals.

In cases of professional service agreements, requiring professional liability coverage:

If the insurer by which a Consultant is insured against professional liability does not so defend the City and applicable agents and/or staff, and the Consultant is adjudicated to be liable by a trier of fact, the City shall be entitled to reasonable attorney's fees and costs to be paid to the City by the Consultant in an amount which is proportionate to the liability of the of the Consultant.

Nothing in this contract shall be interpreted to waive nor does the City, by entering into this contract, waive any of the provisions found in Chapter 41 of the Nevada Revised Statutes.

16. Licenses and Permits:

The Contractor shall procure at his own expense all necessary licenses and permits and shall adhere to all the laws, regulations and ordinances applicable to the performance of this Contract.

All Contractors, Sub-Contractors and Suppliers doing business within the City of Sparks are required to obtain a current business license from the City of Sparks prior to commencement of this contract. Per Sparks Municipal Code Section 5.08.020A: "It is unlawful for any person to transact business in the City without first having obtained a license from the City to do so and without complying with all applicable provisions of this title and paying the fee therefore."

17. Insurance:

BIDDERS' ATTENTION IS DIRECTED TO THE INSURANCE REQUIREMENTS BELOW. IT IS HIGHLY RECOMMENDED THAT BIDDERS CONFER WITH THEIR RESPECTIVE INSURANCE CARRIERS OR BROKERS TO DETERMINE IN ADVANCE OF BID SUBMISSION THE AVAILABILITY OF INSURANCE CERTIFICATES AND ENDORSEMENTS AS PRESCRIBED AND PROVIDED HEREIN. IF THE APPARENT LOW BIDDER FAILS TO COMPLY STRICTLY WITH THE INSURANCE REQUIREMENTS, THAT BIDDER MAY BE DISQUALIFIED FROM AWARD OF THE CONTRACT.



The City may, unless otherwise required by law, waive or reduce the insurance requirements itemized here, at the discretion of the city’s Contracts and Risk Manager.

Should work be required on City premises or within the public right-of-way, upon award of the contract, the bidder shall provide proof of insurance for the types of coverage, limits of insurance and other terms specified herein, prior to initiation of any services under City, Bid, Proposal or Contract. Coverage shall be from a company authorized to transact business in the State of Nevada and the City of Sparks and shall meet the following minimum specifications:

Contractor shall at its own expense carry and maintain at all times the following insurance coverage and limits of insurance no less than the following or the amount customarily carried by Contractor or any of its subcontractors, whichever is greater. Contractor shall also cause each subcontractor employed by Contractor to purchase and maintain insurance of the type specified herein. All insurers must have AM Best rating not less than A-VII, and be acceptable to the City. Contractor shall furnish copies of certificates of insurance evidencing coverage for itself and for each subcontractor. Failure to maintain the required insurance may result in termination of this contract at City’s option. If Contractor fails to maintain the insurance as set forth herein, City shall have the right, but not the obligation, to purchase said insurance at Contractor’s expense.

Contractor shall provide proof of insurance for the lines of coverage, limits of insurance and other terms specified below prior to initiation of any services. Coverage shall be from a company authorized to transact business in the State of Nevada and the City of Sparks. Contractor and any of its subcontractors shall carry and maintain coverage and limits no less than the following or the amount customarily carried by Contractor or any of its subcontractors, whichever is greater.

Applicable to this Contract	Insurance Type	Minimum Limit	Insurance Certificate	Additional Insured	Waiver of Subrogation
Yes	General Liability/Umbrella (Excess) Liability	\$2,000,000	✓	✓	✓
Yes	Automobile Liability	\$1,000,000	✓	✓	
Yes	Workers’ Compensation	Statutory	✓	N/A	✓
Yes	Employer’s Liability	\$1,000,000	✓	N/A	
No	Professional Liability	\$1,000,000	✓	N/A	N/A
No	Pollution Legal Liability	\$1,000,000	✓	N/A	N/A

Commercial General Liability

Contractor shall carry and maintain Commercial General Liability (CGL) and, if necessary to meet required limits of insurance, commercial umbrella/excess liability insurance with a total limit of not less than the limits specified herein.



For contracts that are for the construction or improvement of public facilities, the Contractor shall obtain and maintain products and completed operations liability coverage through the statute of repose after completion of the project. Continuing commercial umbrella coverage, if any, shall include liability coverage for damage to the insured's completed work equivalent to that provided under ISO form CG 00 01.

There shall be no endorsement or modification of the CGL limiting the scope of coverage for liability arising from pollution, explosion, collapse, underground property damage, or damage to the named insured's work unless Subcontractor carries and maintains separate policies providing such coverage and provides Contractor evidence of insurance confirming the coverage.

Minimum Limits of Insurance

- \$2,000,000** Each Occurrence Limit for bodily injury and property damage
- \$2,000,000** General Aggregate Limit
- \$2,000,000** Products and Completed Operations Aggregate Limit
- \$10,000** Medical Expense Limit

If Commercial General Liability Insurance or other form with a general aggregate limit is used, it shall be revised to apply separately to this PROJECT or LOCATION.

Coverage Form

Coverage shall be at least as broad as the unmodified Insurance Services Office (ISO) Commercial General Liability (CGL) "Occurrence" form CG 00 01 04/13 or substitute form providing equivalent coverage and shall cover liability arising from premises, operations, independent contractors, products-completed operations, personal and advertising injury, and liability assumed under an insured contract (including the tort liability of another assumed in a business contract).

Additional Insured

City, its officers, agents, employees, and volunteers are to be included as insureds using the applicable ISO additional insured endorsement(s) or substitute forms providing equivalent coverage, in respects to damages and defense arising from: activities performed by or on behalf of Contractor, including the insured's general supervision of Contractor; products and completed operations of Contractor; premises owned, occupied, or used by Contractor. The coverage shall contain no special limitations on the scope of protection afforded to City, its officers, employees, or volunteers. Additional insured status for City shall apply until the expiration of time within which a claimant can bring suit per applicable state law.

Primary and Non-Contributory

Contractor's insurance coverage shall apply as primary insurance with respect to any other insurance or self-insurance programs afforded to City, its officers, agents, employees, and volunteers. There shall be no endorsement or modification of the CGL to make it excess over other available insurance; alternatively, if the CGL states that it is excess or pro rata, the policy shall be endorsed to be primary with respect to the additional insured. Any insurance or self-insurance maintained by City, its officers, employees, or volunteers shall be excess of Contractor's insurance and shall not contribute with it in any way.

Waiver of Subrogation



Contractor waives all rights against City and its agents, officers, directors and employees for recovery of damages to the extent these damages are covered by the commercial general liability or commercial umbrella liability insurance maintained pursuant to this agreement. Insurer shall endorse CGL policy as required to waive subrogation against the City with respect to any loss paid under the policy.

Endorsements

Policy forms or endorsements are required confirming coverage for all required additional insureds. The forms or endorsements for CGL shall be at least as broad as the unmodified ISO additional insured endorsement CGO 20 10 07/04 and CG 20 37 07/04 or substitute forms providing additional insured coverage for products and completed operations.

A waiver of subrogation in favor of City shall be endorsed to the policy using an unmodified Waiver of Transfer of Rights of Recovery of Others to Us ISO CG 24 04 05 09, or a substitute form providing equivalent coverage.

Electronic Data Liability

If any underground work will be performed, Contractor shall maintain electronic data liability insurance applicable to the Project and insuring against liability arising out of the loss of, loss of use of, damage to, corruption of, inability to access, or inability to manipulate electronic data. This coverage shall be maintained with a limit of liability of not less than \$1,000,000 and provide coverage at least as broad as electronic data liability coverage form CG 04 37 (or substitute form providing equivalent coverage).

Railroad Protective Liability

For any construction or demolition work within fifty (50) feet of a railroad, Contractor shall maintain Railroad Protective Liability insurance on behalf of and in the name of the railroad, as named insured, with a limit of \$6,000,000 per occurrence or higher limit if required by the railroad. Contractor shall also ensure that any exclusions pertaining to the indemnification of a railroad are removed from its CGL policy or that ISO form CG 24 17 (Contractual Liability-Railroads Endorsements) is included in the coverage.

Business Automobile Liability

Minimum Limits of Insurance

\$1,000,000 Combined Single Limit per accident for bodily injury and property damage or the limit customarily carried by Contractor, whichever is greater. No aggregate limit may apply. Coverage may be combined with Excess/Umbrella Liability coverage to meet the required limit.

Coverage Form

Coverage shall be at least as broad as the unmodified Insurance Services Office (ISO) Business Automobile Coverage form CA 00 01 10/13, CA 00 25 10/13, CA 00 20 10/13 or substitute form providing equivalent coverage. Such insurance shall cover liability arising out of any auto (including owned, hired, and non-owned autos).

Pollution liability coverage at least as broad as that provided under the ISO pollution liability—broadened coverage for covered autos endorsement (CA 99 48) shall be provided, and the Motor Carrier Act endorsement (MCS 90) shall be attached for all contracts involving transportation of “hazardous



material” as this term is defined by applicable law, including, but not limited to, waste, asbestos, fungi, bacteria and mold.

Additional Insured

City, its officers, agents, employees, and volunteers are to be included as insureds with respect to damages and defense arising from the ownership, maintenance or use of automobiles owned, leased, hired, or borrowed by the Contractor. The coverage shall contain no special limitations on the scope of protection afforded to City, its officers, employees, or volunteers. Additional insured status for City shall apply until the expiration of time within which a claimant can bring suit per applicable state law.

Endorsements

A policy endorsement is required listing all required additional insureds. The endorsement for Business Automobile Liability shall be at least as broad as the unmodified ISO CA 20 48 10/13 or a substitute form confirming City’s insured status for Liability Coverage under the Who Is An Insured Provision contained in Section II of the coverage form ISO CA 00 01 10/13.

Waiver of Subrogation.

Contractor waives all rights against City, its officers, agents, employees, and volunteers for recovery of damages to the extent these damages are covered by the commercial general liability or commercial umbrella liability insurance maintained pursuant to this agreement. Contractor’s insurer shall endorse policy to waive subrogation against City with respect to any loss paid under the policy.

Workers’ Compensation and Employer’s Liability

Contractor shall carry and maintain workers’ compensation and employer’s liability insurance meeting the statutory requirements of the State of Nevada, including but not limited to NRS 616B.627 and NRS 617.210 or provide proof that compliance with the provisions of Nevada Revised Statutes Chapters 616A-D and all other related chapters is not required. It is understood and agreed that there shall be no coverage provided for Contractor or any Subcontractor of the Contractor by the City. Contractor agrees, as a precondition to the performance of any work under this Agreement and as a precondition to any obligation of the City to make any payment under this Agreement to provide City with a certificate issued by an insurer in accordance with NRS 616B.627 and with a certificate of an insurer showing coverage pursuant to NRS 617.210.

It is further understood and agreed by and between City and Contractor that Contractor shall procure, pay for and maintain the above-mentioned coverage at Contractor's sole cost and expense.

Should Contractor be self-funded for workers’ compensation and employer’s liability insurance, Contractor shall so notify City in writing prior to the signing of this Contract. City reserves the right to approve said retentions, and may request additional documentation, financial or otherwise, for review prior to the signing of this Contract.

Upon completion of the project, Contractor shall, if requested by City, provide a Final Certificate for itself and each Subcontractor showing that Contractor and each Subcontractor had maintained the required Workers Compensation and Employer’s Liability by paying all premiums due throughout the entire course of the project.



Nevada law allows the following to reject workers' compensation coverage if they do not use employees or subcontractors in the performance of work under the contract:

- Sole proprietors (NRS 616B.627 and NRS 617.210)
- Unpaid officers of quasi-public, private or nonprofit corporations (NRS 616B.624 and NRS 617.207)
- Unpaid managers of limited liability companies (NRS 616B.624 and NRS 617.207)
- An officer or manager of a corporation or limited liability company who owns the corporation or company (NRS 616B.624 and NRS 617.207)

If a contractor has rejected workers' compensation coverage under applicable Nevada law, the contractor must indicate the basis for the rejection of coverage and complete, sign and have notarized an Affidavit of Rejection of Coverage. The Affidavit must be completed, signed and notarized prior to performance of any work.

Minimum Limits of Insurance

Workers' Compensation:	Statutory Limits
Employer's Liability:	\$1,000,000 Bodily Injury by Accident – Each Accident
	\$1,000,000 Bodily Injury by Disease – Each Employee
	\$1,000,000 Bodily Injury by Disease – Policy Limit

Coverage Form

Coverage shall be at least as broad as the unmodified National Council on Compensation Insurance (NCCI) Workers Compensation and Employer's Liability coverage form WC 00 00 07/11 or substitute form providing equivalent coverage.

OTHER INSURANCE COVERAGES (IF APPLICABLE)

Professional Liability Insurance (if Applicable) \$1,000,000 each claim limits of liability or whatever limit is customarily carried by the Contractor, whichever is greater, for design, design-build or any type of professional services. If coverage is required on a claims-made or claims-made and reported basis, any applicable retroactive or pending & prior litigation dates must precede the effective date of this contract. Continuous coverage shall be maintained, or an extended reporting period shall be obtained for a period of at least three (3) years following completion of the project.

Contractors Pollution Liability Insurance (If Applicable)- \$1,000,000 per occurrence and \$2,000,000 aggregate or whatever amount is acceptable to the City for any exposure to "hazardous materials" as this term is defined in applicable law, including but not limited to waste, asbestos, fungi, bacterial or mold.

Coverage shall apply to bodily injury; property damage, including loss of use of damaged property or of property that has not been physically injured; cleanup costs; and defense, including costs and expenses incurred in the investigation, defense, or settlement of claims.

City shall be included as an insured under Contractor's pollution liability insurance.



If coverage is required on a claims-made or claims-made and reported basis, any applicable retroactive or pending & prior litigation dates must precede the effective date of this contract. Continuous coverage shall be maintained, or an extended reporting period shall be obtained for a period of at least three (3) years following completion of the project.

If the scope of services as defined in this contract includes the disposal of any hazardous materials from the job site, Contractor must furnish to City evidence of pollution liability insurance maintained by the disposal site operator for losses arising from the insured facility accepting waste under this contract. Coverage certified to the City under this section must be maintained in minimum amounts of \$1,000,000 per loss, with an annual aggregate of at least \$2,000,000.

Lower tier sub-subcontractors, Truckers, Suppliers: Evidence confirming lower tier subcontractors, truckers and suppliers are maintaining valid insurance prior to beginning work on the project to meet the requirements set forth herein on Subcontractor, including but not limited to all additional insured requirements of Subcontractor.

ALL COVERAGES

Coverage shall not be suspended, voided, canceled, or non-renewed by either CONTRACTOR or by the insurer, reduced in coverage or in limits except after thirty (30) days' prior written notice has been given to CITY except for ten (10) days' notice for nonpayment of premium.

DEDUCTIBLES AND RETENTIONS

Any deductibles or self-insured retentions that exceed \$100,000.00 per occurrence or claim must be declared to and approved by the City's Contracts and Risk Manager and prior to signing this Contract. City is entitled to request and receive additional documentation, financial or otherwise, prior to giving its approval of the deductibles and self-insured retentions. Any changes to the deductibles or self-insured retentions made during the term of this Contract or during the term of any policy must be approved by City's Contracts and Purchasing Manager prior to the change taking effect. Contractor is responsible for any losses within deductibles or self-insured retentions.

OTHER INSURANCE PROVISIONS

Should City and Contractor agree that higher coverage limits are needed warranting a project policy, project coverage shall be purchased and the premium for limits exceeding the above amount may be borne by City. City retains the option to purchase project insurance through Contractor's insurer or its own source.

Any failure to comply with reporting provisions of the policies shall not affect coverage provided to City, its officers, agents, employees, or volunteers.

ACCEPTABILITY OF INSURERS

Insurance is to be placed with insurers with a Best's rating of no less than A-VII and acceptable to the City. City, with the approval of the Risk Manager, may accept coverage with carriers having lower Best's ratings upon review of financial information concerning Contractor and insurance carrier. City reserves the right to require that Contractor's insurer be a licensed and admitted insurer in the State of Nevada, or meet any applicable state and federal laws and regulations for non-admitted insurance placement.



VERIFICATION OF COVERAGE

Contractor shall furnish City with certificates of insurance and with original endorsements affecting coverage required by this contract. The certificates and endorsements for each insurance policy are to be signed by a person authorized by that insurer to bind coverage on its behalf.

Prior to the start of any Work, Contractor must provide the following documents to City of Sparks, Attention: Purchasing Division, P.O. Box 857, Sparks, NV 89432-0857:

- A. **Certificate of Insurance.** Contractor must provide a Certificate of Insurance form to the City of Sparks to evidence the insurance policies and coverage required of Contractor.

- B. **Additional Insured Endorsements.** An original Additional Insured Endorsement, signed by an authorized insurance company representative, must be submitted to the City of Sparks, by attachment to the Certificate of Insurance, to evidence the endorsement of the City of Sparks as additional insured.

- C. **Policy Cancellation Endorsement.** Except for ten (10) days' notice for non-payment of premium, each insurance policy shall be endorsed to specify that without thirty (30) days prior written notice to the City of Sparks, the policy shall not be suspended, voided, cancelled or non-renewed, and shall provide that notices required by this paragraph shall be sent by certified mailed to the address specified above. A copy of this signed endorsement must be attached to the Certificate of Insurance. If endorsements are not available, Contractor shall be responsible to provide prior written notice to City as soon as practicable upon receipt of any notice of cancellation, non-renewal, reduction in required limits or other material change in the insurance required under this Agreement.

- D. **Bonds (as Applicable).** Bonds as required and/or defined in the original bid documents.

All certificates and endorsements are to be addressed to the City of Sparks, Purchasing Division and be received and approved by City before work commences. The City reserves the right to require complete certified copies of all required insurance policies at any time.

SUBCONTRACTORS

Contractor shall include all Subcontractors as insureds under its policies or shall furnish separate certificates and endorsements for each Subcontractor. All coverages for Subcontractors shall be subject to all the requirements stated herein.

MISCELLANEOUS CONDITIONS

1. Contractor shall be responsible for and remedy all damage or loss to any property, including property of City, caused in whole or in part by Contractor, any Subcontractor, or anyone employed, directed, or supervised by Contractor.
2. Nothing herein contained shall be construed as limiting in any way the extent to which Contractor may be held responsible for payment of damages to persons or property resulting from its operations or the operations of any Subcontractors under it, and such coverage and



limits required herein shall not be deemed as a limitation on Contractor's liability under the indemnities granted to City in this contract.

3. In addition to any other remedies City may have if Contractor fails to provide or maintain any insurance policies or policy endorsements to the extent and within the time herein required, City may, at its sole option:
 - a. Purchase such insurance to cover any risk for which City may be liable through the operations of Contractor under this Agreement and deduct or retain the amount of the premiums for such insurance from any sums due under the Agreement;
 - b. Order Contractor to stop work under this Agreement and/or withhold any payments which become due Contractor here under until Contractor demonstrates compliance with the requirements hereof; or,
 - c. Terminate the Agreement.
4. If Contractor's liability policies do not contain the standard ISO separation of insureds condition, or a substantially similar clause, they shall be endorsed to provide cross-liability coverage.

18. Liquidated Damages:

If the Product is not delivered/Project is not completed within the time stipulated in the bid, the Contractor shall pay to the City of Sparks as fixed, agreed and liquidated damages for delay and not as a penalty (it being impossible to determine the actual damages occasioned by the delay) **\$AMT** for each day of delay until delivery is completed; the Contractor shall be liable to the City of Sparks for the amount herein. This amount may be deducted from money due or to become due to the Contractor as compensation under this proposal in the event the Contractor fails to meet delivery schedules or product specifications.

19. Material Breach of Contract:

In the event Contractor fails to deliver the product and services as contracted for herein, to the satisfaction of the City of Sparks or otherwise fails to perform any provisions of this Contract, the City, after providing five (5) days written notice and Contractor's failure to cure such breach within the time specified in the notice, may without waiving any other remedy, make good the deficiencies and deduct the actual cost of providing alternative products and/or services from payment due the Contractor. Non-performance after the first notice of non-performance shall be considered a material breach of contract.

20. Force Majeure:

Neither party to the Contract shall be held responsible for delay or default caused by fire, riot, acts of God, and/or war which is beyond that party's reasonable control. City may terminate the Contract upon written notice after determining such delay or default will reasonably prevent successful performance of the Contract.

21. Termination:

The City may terminate the Contract for material breach of contract upon ten (10) days written notice and recover all damages, deducting any amount still due the Contractor from damages owed to the City, or seek other remedy including action against all bonds. The Contractor may terminate the Contract for material breach of contract upon thirty (30) days written notice to the City.



22. Assignment:

All of the terms, conditions and provisions of this Contract, and any amendments thereto, shall inure to the benefit of and be binding upon the parties hereto, and their respective successors and assigns. The Contractor shall not assign this Contract without the written consent of the City which will not be unreasonably withheld.

23. Entire Contract:

This Contract constitutes the entire agreement of the parties and shall supersede all prior offers, negotiations, agreements and contracts whether written or oral. Any modifications to the terms and conditions of this Contract must be in writing and signed by both parties.

24. Severability:

If any part of this Contract is found to be void it will not affect the validity of the remaining terms of this Contract which will remain in full force and effect.

25. Headings:

Paragraph titles or captions contained in this Contract are inserted only as a matter of convenience and for reference only, and in no way define, limit, extend, or describe the scope of this Contract or the intent of any provision herein.

26. Singular Includes the Plural; Gender; Title Reference:

Whenever the singular number is used in this Contract and when required by the context, the same shall include the plural, and the use of any gender, be it masculine, feminine or neuter, shall include all of the genders, and the word "person" or "entity" shall include corporation, firm, partnership, or any other combination or association.

The use of the title "Bidder", "Vendor", "Contractor" or "Consultant" within this contract or associated bid documents shall be deemed interchangeable and shall refer to the person or entity with whom the City of Sparks is contracting for the service or product referenced within this contract.

27. Execution:

The parties agree to execute such additional documents and to take such additional actions as are reasonably necessary or desirable to carry out the purposes hereof. They also agree, acknowledge and represent that all corporate authorizations have been obtained for the execution of this Contract and for the compliance with each and every term hereof. Each undersigned officer, representative or employee represents that he or she has the authority to execute this Contract on behalf of the party for whom he or she is signing.



THIS SPACE INTENTIONALLY LEFT BLANK



IN WITNESS WHEREOF, the City of Sparks has caused this Contract to be executed by its officers thereunto duly authorized and the Consultant has subscribed same, all on the day and year first above written.

(Vendor)

CITY OF SPARKS, NEVADA
A Municipal Corporation

By: _____

By: _____
Ed Lawson, Mayor

(Title)

APPROVED AS TO FORM

ATTEST:

City Attorney

City Clerk

CITY OF SPARKS, NEVADA - BOND OF FAITHFUL PERFORMANCE

Bid #: _____

Bond #: _____

Surety Rating: _____

NV License #: _____

Appt. Agent Countersigning - List below with address

KNOW ALL MEN BY THESE PRESENTS: That WHEREAS, the City of Sparks in the State of Nevada has awarded to **CONTRACTORNAME** hereinafter designated as the "Principal" a contract for Bid # **BIDNUMBER**, PWP # **PWPNUMBER**, for the **TITLE** and

WHEREAS, said Principal is required under the terms of said contract to furnish a bond for the faithful and proper performance of the Contract and the Bonding Company has an "A" or better rating with Moody's or A.M. Best and T-Listed with the U.S. Treasury Department;

NOW, THEREFORE, we the Principal and _____ as Surety, are held and firmly bound unto the City of Sparks in the State of Nevada, in the penal sum of **WRITTENAMOUNT** dollars (**\$AMOUNT**), lawful money of the United States, being not less than one hundred percent (100%) of the estimated contract cost of the work, for the payment of which sum well and truly to be made, we bind ourselves, our heirs, executors, administrators and successors, jointly and severally, firmly by these presents.

THE CONDITION OF THIS OBLIGATION IS SUCH that if the above bound Principal, his or its heirs, executors, administrators, successors or assigns, shall in all things stand to and abide by, and well and truly keep and faithfully perform the covenants, conditions and agreements in the said contract and any alterations made as therein provided on his or their part to be kept and performed at the time and in the manner therein specified, and in all respects according to their true intent and meaning, and shall indemnify and save harmless the City of Sparks in the State of Nevada, its officers and agents as therein stipulated, then this obligation shall become null and void; otherwise, it shall be and remain in full force and virtue.

As a condition precedent to the satisfactory completion of the said contract, the above obligation shall hold good for a period of one (1) year after the completion and acceptance of the said work, during which time, if the above bounden principal, his or its heirs, executors, administrators, successors or assigns shall fail to make full, complete and satisfactory repair and replacements or totally protect the said City of Sparks in the State of Nevada from loss or damage made evident during said period of one (1) year from the date of acceptance of said works, and resulting from or caused by defective materials or faulty workmanship in the prosecution of the work done, the obligation in the said sum of **WRITTENAMOUNT** dollars (**\$AMOUNT**), shall remain in full force and virtue; otherwise the above obligation shall be void.

And the said Surety, for value received, hereby stipulates and agrees that no change, extension of time, alteration, or addition to the terms of the contract or to the work to be performed thereunder or the specifications accompanying the same shall in anyway effect its obligations on this bond, and it does hereby waive notice of any such change, extension of time, alteration, or addition to the terms of the contract, to the work or to the specifications.

IN WITNESS WHEREOF, the above bound parties have executed this instrument under their seals this ____ day of _____, 20__, the name and corporate party being hereto affixed and these presents duly signed by its undersigned representative, pursuant to authority of its governing body.

Principal

By _____

Surety
By _____

CITY OF SPARKS, NEVADA – Payment Bond – Labor & Materials

Bid #: _____

Bond #: _____

Surety Rating: _____

NV License #: _____

Appt. Agent Countersigning - List below with address

KNOW ALL MEN BY THESE PRESENTS: That WHEREAS, the City of Sparks in the State of Nevada, has awarded to **CONTRACTORNAME** hereinafter designated as the “Principal” a contract for Bid # **BIDNUMBER**, PWP # **PWPNUMBER**, for the **TITLE** and

WHEREAS, said Principal is required under the terms of said contract to furnish a Bond for the faithful and proper performance of the Contract and the Bonding Company has an “A” or better rating with Moody’s or A.M. Best and T-Listed with the U.S. Treasury Department;

NOW, THEREFORE, we, the Principal, and _____ as Surety, are held and firmly bound unto the City of Sparks in the State of Nevada, in the penal sum of **WRITTENAMOUNT** dollars (\$**AMOUNT**), lawful money of the United States, being not less than one hundred percent (100%) of the estimated contract cost of the work for the payment of which sum well and truly to be made, we bind ourselves, our heirs, executors, administrators, and successors, jointly and severally firmly by these presents.

NOW, THEREFORE, THE CONDITION OF THIS OBLIGATION IS SUCH that if the above bounden principal, his or its heirs, executors, administrators, successors, or assigns, shall fail to pay for any materials, provisions, provender or other supplies, implements, or machinery used in, upon, for, or about the performance of the work contracted to be done or for any work or labor thereon of any kind, or for amounts due under the Unemployment Compensation Law with respect to such work or labor as required by the provisions of NRS 612, and provided that the claimant shall have complied with the provisions of said law, the Surety hereon will pay for the same within thirty (30) calendar days an amount not exceeding the sum specified in this bond, then the above obligation shall be null and void; otherwise to remain in full force and account. In case suit is brought upon this bond, the said Surety agrees to pay a reasonable attorney’s fees to be fixed by the Court.

The Bond shall insure to the benefit of any and all persons, companies and corporations entitled to file claims under NRS 339 as to give a right of action to them or their assigns in any suit brought upon this Bond.

IN WITNESS WHEREOF, the above bound parties have executed this instrument under their seals this ____ day of _____, 20____, the name and corporate seal of each corporate party being hereto affixed and these presents duly signed by its undersigned representative, pursuant to authority of its governing body.

Principal

By _____

Surety

By _____